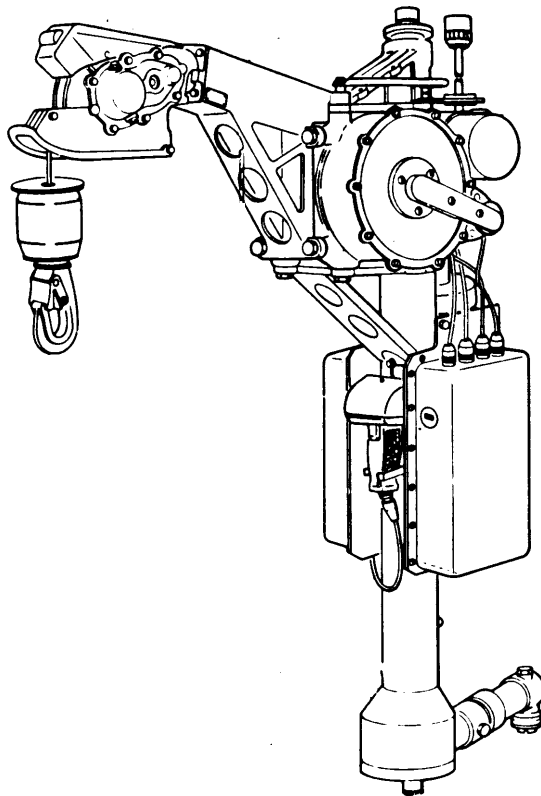


TM 55-1680-320-23&P

TECHNICAL MANUAL

AVIATION UNIT AND
INTERMEDIATE MAINTENANCE
(INCLUDING REPAIR PARTS AND
SPECIAL TOOLS LIST)

**HIGH PERFORMANCE RESCUE
HOIST ASSEMBLY**



PART NO. 42305R1
NSN 1680-01-058-3671

"Approved for public release; distribution is unlimited."

HEADQUARTERS, DEPARTMENT OF THE ARMY

22 AUGUST 1989

Warning and First Aid Data Page**WARNING**

Personnel performing operations, procedures, and practices which are included or implied in this technical manual shall observe the following warnings. Disregard of these warnings and precautionary information can cause serious injury, or death.

Warnings, cautions, and notes are used to emphasize important and critical instructions and are used for the following conditions:

WARNING

An operating procedure, practice, etc., which, if not correctly followed, could result in personal injury or loss of life.

CAUTION

An operating procedure, practice, etc., which, if not strictly observed, could result in damage to or destruction of equipment.

NOTE

An operating procedure, condition, etc., which it is essential to highlight,

WARNING

Rescue hoist cable cutter contains an explosive cartridge. Use extreme care when handling to prevent injury to personnel. Static producing clothing prohibited. When disconnecting electrical connector from cutter, install a piece of aluminum foil between cartridge pins and install cutter shipping cap to prevent injury

Ensure external electrical power is removed from system prior to installing rescue hoist. Activated electricity could cause injury to personnel or damage to equipment.

Enlist the help of an aide during installation of rescue hoist or heavy components to prevent injury or component damage.

Use cleaning solvent in a well-ventilated area. Avoid prolonged breathing of fumes. Keep away from open flame. Solvent is flammable. Use approved safety equipment.

FOR ARTIFICIAL RESPIRATION, REFER TO FM21-11.

Use approved personal protective equipment (goggles/face shield) when using compressed air. Air pressure is restricted to a maximum of 35 psi (241.5 kPa). Do not direct airstream towards self or other personnel.

Automatic transmission fluid is toxic to skin, eyes and respiratory tract. Avoid prolonged or repeated skin contact. Good general ventilation is normally required.

CHANGE

NO. 9

HEADQUARTERS
DEPARTMENT OF THE ARMY
WASHINGTON, D.C., 15 December 2003

Aviation Unit and Intermediate Maintenance
(Including Repair Parts and Special Tools List)

**HIGH PERFORMANCE RESCUE
HOIST ASSEMBLY**

**PART NO. 42305R1
NSN 1680-01-058-3671**

DISTRIBUTION STATEMENT A: Approved for public release; distribution is unlimited.

TM 55-1680-320-23 & P, 22 August 1989, is changed as follows:

1. Remove and insert pages as indicated below. New or changed text material is indicated by a vertical bar in the margin. An illustration change is indicated by a miniature pointing hand.

Remove Pages

A through C/(D blank)
2-1 through 2-8
2-39 through 2-52
2-57 and 2-58
2-61 through 2-64
2-64.1 and 2-64.2
2-65 through 2-72
2-75 through 2-98
2-105 through 2-112
2-115 through 2-120
2-123 through 2-126
2-126.1 and 2-126.2
2-129 through 2-136
2-139 through 2-142
2-145 and 2-146
3-1 through 3-8
3-41 through 3-46
3-51 through 3-54
3-65 through 3-80

Insert Pages

A through D
2-1 through 2-8
2-39 through 2-52
2-57 and 2-58
2-61 through 2-64
2-64.1 and 2-64.2
2-65 through 2-72
2-75 through 2-98
2-105 through 2-112
2-115 through 2-120
2-123 through 2-126
2-126.1 and 2-126.2
2-129 through 2-136
2-139 through 2-142
2-145 and 2-146
3-1 through 3-8
3-41 through 3-46
3-51 through 3-54
3-65 through 3-80

Remove Pages

3-83 and 3-84
3-89 and 3-96
3-103 through 3-110
3-113 and 3-114
3-125 through 3-128
3-135 through 3-142
3-147 through 3-152
C-7 and Figure C-1
C-1-1 and C-1-2
C-18-3 and C-18-4

Insert Pages

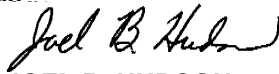
3-83 and 3-84
3-89 and 3-96
3-103 through 3-110
3-113 and 3-114
3-125 through 3-128
3-135 through 3-142
3-147 through 3-152
C-7 and Figure C-1
C-1-1 and C-1-2
C-18-3 and C-18-4

2. Retain this sheet in front of manual for reference purposes.

By Order of the Secretary of the Army:

PETER J. SCHOOMAKER
General, United States Army
Chief of Staff

Official: _____



JOEL B. HUDSON

Administration Assistant to the
Secretary of the Army

0329701

DISTRIBUTION

To be distributed in accordance with Initial Distribution No. (IDN) 311710, requirements for TM 55-1680-320-23 & P.

CHANGE

NO. 8

HEADQUARTERS
DEPARTMENT OF THE ARMY
WASHINGTON, D.C. 09 JULY 2001

Aviation Unit and Intermediate Maintenance
(Including Repair Parts and Special Tools List)

HIGH PERFORMANCE RESCUE
HOIST ASSEMBLY

PART NO. 42305R1
NSN 1680-01-058-3671

DISTRIBUTION STATEMENT A: Approved for public release; distribution is unlimited.

ENVIRONMENTAL/HAZARDOUS MATERIAL INFORMATION

This document has been reviewed for the presence of Class I Ozone Depleting Chemicals. As of 14 June 1995, the status is: All references to Class I Ozone Depleting Chemicals have been removed from this document by substitution with chemicals that do not cause atmospheric ozone depletion.

TM 55-1680-320-23&P, dated 22 August 1989, is changed as follows:

1. Remove and insert pages as indicated below. New or changed text material is indicated by a vertical bar in the margin. An illustration change is indicated by a miniature pointing hand.

Remove pages

i and ii

1-1 and 1-2

2-9 and 2-10

2-15 and 2-16

2-17 thru 2-20

2-41 and 2-42

2-63 and 2-64

2-125 and 2-126

2-127 and 2-128

2-129 and 2-130

2-145 and 2-146

3-15 and 3-16

3-53 and 3-54

Insert pages

A thru C

i and ii

1-1 and 1-2

1-13 and 1-14

2-9 and 2-10

2-15 and 2-16

2-16.1 / (2-16.2 blank)

2-17 thru 2-20

2-41 and 2-42

2-63 and 2-64

2-125 and 2-126

2-126.1 and 2-126.2

2-127 and 2-128

2-129 and 2-130

2-145 and 2-146

3-15 and 3-16

3-53 and 3-54

Remove pages
3-147 thru 3-150
3-153 / (3-154 blank)

Insert pages
3-147 thru 3-150
3-153 / (3-154 blank)
4-1 / (4-2 blank)

2. Retain this sheet in front of manual for reference purposes.

By Order of the Secretary of the Army:

ERIC K. SHINSEKI
General, United States Army
Chief of Staff

Official:



JOEL B. HUDSON
Administrative Assistant to the
Secretary of the Army
0114904

DISTRIBUTION:

To be distributed in accordance with Initial Distribution Number (IDN) 311710, requirements for TM 55-1680-320-23&P.

CHANGE

NO.7

HEADQUARTERS
DEPARTMENT OF THE ARMY
WASHINGTON, D.C., 1 October 1996

Aviation Unit and Intermediate Maintenance
(Including Repair Parts and Special Tools List)

**HIGH PERFORMANCE RESCUE
HOIST ASSEMBLY
PART NO. 42305R1
NSN 1680-01-058-3671**

DISTRIBUTION STATEMENT A: Approved for public release; distribution is unlimited.

TM 55-1680-320-23&P, 22 August 1989, is changed as follows:

1. Remove and insert pages as indicated below. New or changed text material is indicated by a vertical bar in the margin. An illustration change is indicated by a miniature pointing hand.

Remove pages

i and ii
Figure C-11. (Sheet 2 of 3) and
Figure C-11 (Sheet 3 of 3)
C-17-1 and Figure C-18 (Sheet 1 of 3)

Insert pages

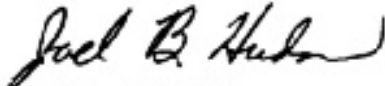
i and ii
Figure C-11. (Sheet 2 of 3) and
Figure C-11 (Sheet 3 of 3)
C-17-1 and Figure C-18 (Sheet 1 of 3)

2. Retain this sheet in front of manual for reference purposes.

TM 55-1680-320-23&P

C7

By Order of the Secretary of the Army:

Officer: 
JOEL B. HUDSON
*Administrative Assistant to the
Secretary of the Army*
02508

DENNIS J. REIMER
*General, United States Army
Chief of Staff*

DISTRIBUTION:

To be distributed in accordance with DA Form 12-31-E, block no. 1710, requirements for TM 55-1680-320-23&P.

CHANGE
NO. 6

HEADQUARTERS
DEPARTMENT OF THE ARMY
WASHINGTON, D. C., 1 December 1995

Aviation Unit and Intermediate Maintenance
(Including Repair Parts and Special Tools List)

**HIGH PERFORMANCE RESCUE
HOIST ASSEMBLY
PART NO. 42305R1
NSN 1660-01-056-3671**

DISTRIBUTION STATEMENT A: Approved for public release; distribution is unlimited

TM 55-1680-320-23&P, 22 August 1989, is changed as follows:

1. Remove and insert pages as indicated below. New or changed text material is indicated by a vertical bar in the margin. An illustration change is indicated by a miniature pointing hand.

Remove pages

xi and xii
2-64.1 and 2-64.2
3-139 and 3-140
3-145 and 3-146
Fig. C-3, Sheets 3 and 4
C-3-1 and C-3-2
C-11-1 and C-11-2
C-15-1 and C-16-1
C-17-1 and Fig. C-18 (Sheet 1 of 3)
C-18-1 and C-18-2
C-22-1 and Fig. C-23
C-24-1
I-1 through I-6
I-13 and I-14
1-27 through 1-34

Insert pages

xi and xii
2-64.1 and 2-64.2
3-139 and 3-140
3-145 and 3-146
Fig. C-3, Sheets 3 and 4
C-3-1 and C-3-2
C-11-1 and C-11-2
C-15-1 and C-16-1
C-17-1 and Fig. C-18 (Sheet 1 of 3)
C-18-1 and C-18-2
C-22-1 and Fig. C-23
C-24-1
I-1 through I-6
I-13 and I-14
1-27 through 1-34

2. Retain this sheet in front of manual for reference purposes.

By Order of the Secretary of the Army:

Official:

Yvonne M. Harrison

YVONNE M. HARRISON
*Administrative Assistant to the
Secretary of the Army*

01007

DENNIS J. REIMER
*General, United States Army
Chief of Staff*

DISTRIBUTION:

To be distributed in accordance with DA Form 12-31-E, block no. 1710, requirements for TM 55-1680-320-23&P.

CHANGE

NO. 5

HEADQUARTERS
DEPARTMENT OF THE ARMY
WASHINGTON, D. C., 29 April 1994

Aviation Unit and Intermediate Maintenance
(Including Repair Parts and Special Tools List)

**HIGH PERFORMANCE RESCUE
HOIST ASSEMBLY
PART NO. 42305R1
NSN 1680-01-058-3671**

DISTRIBUTION STATEMENT A: Approved for public release; distribution is unlimited

TM 55-1680-320-23&P, 22 August 1989, is changed as follows:

1. Remove and insert pages as indicated below. New or changed text material is indicated by a vertical bar in the margin. An illustration change is indicated by a miniature pointing hand.

Remove pages

1-1 and 1-2
2-63 and 2-64
3-17 and 3-18
3-151 and 3-152
A-1/(A-2 blank)
D-1 and D-2
I-29 and I-30
Index-5/(Index 6 blank)


Insert pages

1-1 and 1-2
2-63 and 2-64
3-17 and 3-18
3-151 and 3-152
A-1/(A-2 blank)
D-1 and D-2
I-29 and I-30
Index-5/(Index 6 blank)

2. Retain this sheet in front of manual for reference purposes.

By Order of the Secretary of the Army:

Official:



MILTON H. HAMILTON

*Administrative Assistant to the
Secretary of the Army*

06723

GORDON R. SULLIVAN

*General, United States Army
Chief of Staff*

DISTRIBUTION:

To be distributed in accordance with DA Form 12-31-E, block no. 1710, requirements for
TM 55-1680-320-24P.

CHANGE

HEADQUARTERS

DEPARTMENT OF THE ARMY

NO. 4

WASHINGTON, D.C., 31 March 1993

Aviation Unit and Intermediate Maintenance
(Including Repair Parts and Special Tools List)

HIGH PERFORMANCE RESCUE
HOIST ASSEMBLY

PART NO. 42305R1
NSN 1680-01-058-3671

DISTRIBUTION STATEMENT A: Approved for public release; distribution is unlimited.

TM 55-1680-320-23&P, 22 August 1989, is changed as follows:

1. Remove and insert pages as indicated below. New or changed text material is indicated by a vertical bar in the margin. An illustration change is indicated by a miniature pointing hand.

Remove pages

i and ii
2-15 and 2-16
2-17 and 2-18
2-19 and 2-20
2-47 and 2-48
2-117 and 2-118
3-15 and 3-16
3-17 and 3-18
C-6-3 and figure 7
C-15-1 and C-16-1
I-3 and I-4
I-5 and I-6
I-13 and I-14
I-19 and I-20

Insert pages

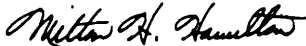
i and ii
2-15 and 2-16
2-17 and 2-18
2-19 and 2-20
2-47 and 2-48
2-117 and 2-118
3-15 and 3-16
3-17 and 3-18
C-6-3 and figure 7
C-15-1 and C-16-1
I-3 and I-4
I-5 and I-6
I-13 and I-14
I-19 and I-20

2. Retain this sheet in front of manual for reference purposes.

By Order of the Secretary of the Army:

GORDON R. SULLIVAN
General, United States Army
Chief of Staff

Official:



MILTON H. HAMILTON
Administrative Assistant to the
Secretary of the Army

03024

DISTRIBUTION :

To be distributed in accordance with DA Form 12-31-E, block no. 1710,
requirements for TM 55-1680-320-23&P.

CHANGE }
 NO. 3 }

HEADQUARTERS
 DEPARTMENT OF THE ARMY
 WASHINGTON, D.C., 29 May 1992

Aviation Unit and Intermediate Maintenance
 (Including Repair Parts and Special Tools List)

HIGH PERFORMANCE RESCUE
 HOIST ASSEMBLY

PART NO. 42305R1
 NSN 1680-01-058-3671

TM 55-1680-320-23 & P, 22 August 1989, is changed as follows:

1. Remove and insert pages as indicated below. New or changed text material is indicated by a vertical bar in the margin. An illustration change is indicated by a miniature pointing hand.

Remove pages

i and ii
 1-1 and 1-2
 2-17 and 2-18
 2-61 through 2-64
 - - - -
 2-105 and 2-106
 2-127 and 2-128
 3-17 and 3-18
 B-7 and B-8
 C-1-1 and C-1-2
 C-2-1 through Figure C-3
 Sheet 3 of 3
 C-3-1 and C-3-2
 C-7-1 and C-7-2
 C-15-1 and C-16-1
 I-1 through I-4
 I-7 and I-8
 I-17 and I-18
 I-21 and I-22
 I-27 and I-28
 I-33 and I-34

Insert pages

i and ii
 1-1 and 1-2
 2-17 and 2-18
 2-61 through 2-64
 2-64.1 and 2-64.2
 2-105 and 2-106
 2-127 and 2-128
 3-17 and 3-18
 B-7 and B-8
 C-1-1 and C-1-2
 C-2-1 through Figure C-3
 Sheet 4 of 4
 C-3-1 and C-3-2
 C-7-1 and C-7-2
 C-15-1 and C-16-1
 I-1 through I-4
 I-7 and I-8
 I-17 and I-18
 I-21 and I-22
 I-27 and I-28
 I-33 and I-34

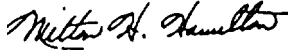
2. Retain this sheet in front of manual for reference purposes.

TM 55-1680-320-23&P

C 3

By Order of the Secretary of the Army:

Official:



MILTON H. HAMILTON
*Administrative Assistant to the
Secretary of the Army*
01747

GORDON R. SULLIVAN
General, United States Army
Chief of Staff

DISTRIBUTION:

To be distributed in accordance with DA Form 12-31-E, block no. 1710, AVUM and AVIM maintenance requirements for TM 55-1680-320-23&P.

HEADQUARTERS
DEPARTMENT OF THE ARMY
WASHINGTON, D.C., 7 March 1991

CHANGE)
NO.2)

Aviation Unit and Intermediate Maintenance
(Including Repair Parts and Special Tools List)

HIGH PERFORMANCE RESCUE
HOIST ASSEMBLY

PART NO. 42305R1
NSN 1680-01-058-3671

TM 55-1680-320-23 & P, 22 August 1989, is changed as follows:

1. Remove and insert pages as indicated below. New or changed text material is indicated by a vertical bar in the margin. An illustration change is indicated by a miniature pointing hand.

Remove pages

i and ii
ix and x
1-11/1-12
2-17 and 2-18
2-43 and 2-44
2-51 and 2-52
2-97 and 2-98
2-125 and 2-126
2-129 and 2-130
3-17 and 3-18
3-45 and 3-46
3-73 and 3-74
3-93 through 3-98
3-113 and 3-114
3-121 and 3-122
3-127 through 3-130
3-149 and 3-150
A-1/A-2
C-2-1 and Figure 3
Sheet 1 of 3
C-3-1 and C-3-2
C-7-1 and C-7-2
C-9-1 and C-9-2
C-11-3 and Figure C-12
C-12-1 and C-12-2
C-18-1 through C-18-4
C-19-1 and C-19-2
1-9 and 1-10
1-13 through 1-18
1-21 through 1-24
1-27 and 1-28
1-31 through 1-35/36
D-1 through D-3/D-4
2028s and Envelopes

Insert pages

i and ii
ix and x
1-11/1-1-12
2-17 and 2-18
2-43 and 2-44
2-51 and 2-52
2-97 and 2-98
2-125 and 2-126
2-129 and 2-130
3-17 and 3-18
3-45 and 3-46
3-73 and 3-74
3-93 through 3-98
3-113 and 3-114
3-121 and 3-122
3-127 through 3-130
3-149 and 3-150
A-1/A-2
C-2-1 and Figure 3
Sheet 1 of 3
C-3-1 and C-3-2
C-7-1 and C-7-2
C-9-1 and C-9-2
C-11-3 and Figure C-12
C-12-1 and C-12-2
C-18-1 through C-18-4
C-19-1 and C-19-2
1-9 and 1-10
1-13 through 1-18
1-21 through 1-24
1-27 and 1-28
1-31 through 1-35/36
D-1 through D-3/D-4
2028s and Envelopes

2. Retain this sheet in front of manual for reference purposes.

By Order of the Secretary of the Army:

Official:

THOMAS F. SIKORA
Brigadier General, United States Army
The Adjutant General

CARL E. VUONO
General, United States Army
Chief of Staff

DISTRIBUTION:

To be distributed in accordance with DA Form 12-31-E, block no 1710, AVUM and AVIM maintenance requirements for TM 55-1680-320-23&P.

CHANGE }
NO. 1 }

HEADQUARTERS
DEPARTMENT OF THE ARMY
WASHINGTON, D.C., 12 July 1990

Aviation Unit and Intermediate Maintenance
(Including Repair Parts and Special Tools List)

HIGH PERFORMANCE RESCUE
HOIST ASSEMBLY

PART NO. 42305R1
NSN 1680-01-058-3671

TM 55-1680-320-23 & P, 22 August 1989, is changed as follows:

1. Change "TM 55-1520-238-23P" to read "TM 55-1680-320-23 & P" on Authentication page in basic manual.
2. Change distribution to read "To be distributed in accordance with DA Form 12-31, AVUM and AVIM Maintenance requirements for All UH-1, series Aircraft, UH-60 Helicopter, Utility (BHIP) and UH-60A Helicopter, Utility (BLACKHAWK)."
3. Remove and insert pages as indicated below. New or changed text material is indicated by a vertical bar in the margin. An illustration change is indicated by a miniature pointing hand.

Remove pages

2-17 and 2-18
3-17 and 3-18

Insert pages

2-17 and 2-18
3-17 and 3-18

4. Retain this sheet in front of manual for reference purposes.

By Order of the Secretary of the Army:

CARL E. VUONO
General, United States Army
Chief of Staff

Official

WILLIAM J. MEEHAN II
Brigadier General, United States Army
The Adjutant General

DISTRIBUTION:

To be distributed in accordance with DA Form 12-31, AVUM and AVIM Maintenance requirements for All UH-1 series Aircraft, UH-60 Helicopter, Utility (BHIP) and UH-60A Helicopter, Utility (BLACKHAWK).

LIST OF EFFECTIVE PAGES

Insert latest changed pages; dispose of superseded pages in accordance with regulations.

NOTE: On a changed page, the portion of the text affected by the latest change is indicated by a vertical line, or other change symbol, in the outer margin of the page. Changes to illustrations are indicated by miniature pointing hands. Changes to wiring diagrams are indicated by shaded areas.

DATES OF ISSUE FOR ORIGINAL AND CHANGED PAGES ARE:

Original 0 22 August 1989	Change 5 29 April 1994
Change 1 12 July 1990	Change 6 1 December 1995
Change 2 7 March 1991	Change 7 1 October 1996
Change 3 29 May 1992	Change 8 9 July 2001
Change 4 31 March 1993	Change 9 15 December 2003

TOTAL NUMBER OF PAGES IN THIS PUBLICATION IS 531, CONSISTING OF THE FOLLOWING:

Page Number	*Change Number	Page Number	*Change Number
Cover	0	2-16.2 blank	8
a	0	2-17 – 2-19	8
b blank	0	2-20 – 2-38	0
A – C	9	2-39	9
D blank	8	2-40	0
i	8	2-41	8
ii	3	2-42 – 2-49	9
iii – viii	0	2-50	0
ix and x	2	2-51	9
xi and xii	6	2-52 – 2-57	0
1-1	8	2-58	9
1-2 – 1-10	0	2-59 and 2-60	0
1-11	2	2-61 – 2-63	9
1-12	0	2-64	8
1-13 and 1-14	8	2-64.1	6
2-1	0	2-64.2	9
2-2	9	2-65 – 2-68	9
2-3	0	2-69	0
2-4	9	2-70 and 2-71	9
2-5	0	2-72 – 2-74	0
2-6	9	2-75	9
2-7	0	2-76 and 2-77	0
2-8	9	2-78 and 2-79	9
2-9	8	2-80 and 2-81	0
2-10 – 2-14	0	2-82 – 2-94	9
2-15 – 2-16	8	2-95	0
2-16.1	8	2-96 – 2-98	9

*Zero in this column indicates an original page.

LIST OF EFFECTIVE PAGES (CON'T)

Page Number	*Change Number	Page Number	*Change Number
2-99 – 2-104	0	3-41	9
2-105 and 2-106	9	3-42 and 3-43	0
2-107	0	3-44 and 3-45	9
2-108 and 2-109	9	3-46 – 3-51	0
2-110	8	3-52 – 3-53	9
2-111 and 2-112	9	3-54	8
2-113 and 2-114	0	3-55 – 3-65	0
2-115 and 2-116	9	3-66 and 3-67	9
2-117	0	3-68 and 3-69	0
2-118	9	3-70	9
2-119	0	3-71	0
2-120	9	3-72	9
2-121 and 2-122	0	3-73	0
2-123	9	3-74 and 3-75	9
2-124	0	3-76	0
2-125	9	3-77 and 3-78	9
2-126	8	3-79	0
2-126.1	8	3-80	9
2-126.2	9	3-81 and 3-82	0
2-127	0	3-83	9
2-128 and 2-129	8	3-84 – 3-88	0
2-130 and 2-131	9	3-89 and 3-90	9
2-132 and 2-133	0	3-91	0
2-134 and 2-135	9	3-92 and 3-93	9
2-136 – 2-138	0	3-94	0
2-139 – 2-141	9	3-95	9
2-142 – 2-144	0	3-96	0
2-145	9	3-97	0
2-146	8	3-98	2
3-1	0	3-99 – 3-102	0
3-2	9	3-103 and 3-104	9
3-3	0	3-105	0
3-4	9	3-106 – 3-109	9
3-5	0	3-110 – 3-113	0
3-6	9	3-114	9
3-7	0	3-115 – 3-120	0
3-8	9	3-121	2
3-9 – 3-14	0	3-122 – 3-124	0
3-15	8	3-125	9
3-16	1	3-126	0
3-17	5	3-127	9
3-18	4	3-128 and 3-129	0
3-19	0	3-130	2
3-20 – 3-40	0	3-131 – 3-135	0

*Zero in this column indicates an original page.

B Change 9

LIST OF EFFECTIVE PAGES (CON'T)

Page Number	*Change Number	Page Number	*Change Number
3-136	9	C-8 (Sheet 2 of 2)	0
3-137	0	C-8-1 and C-8-2	0
3-138 and 3-139	9	Figure C-9	0
3-140	6	C-9-1	2
3-141	0	C-9-2	0
3-142	9	Figure C-10	0
3-143 – 3-145	0	C-10-1	0
3-146	6	Figure C-11 (Sheet 1 of 3)	0
3-147	0	Figure C-11 (Sheet 2 of 3)	0
3-148	9	Figure C-11 (Sheet 3 of 3)	7
3-149	8	C-11-1	6
3-150 – 3-152	9	C-11-2	0
3-153	8	C-11-3	2
3-154 blank	0	Figure C-12	0
4-1	0	C-12-1	0
4-2 blank	0	C-12-2	2
A-1	5	Figure C-13	0
A-2 blank	0	C-13-1	0
B-1 – B-6	0	Figure C-14	0
B-7	3	C-14-1	0
B-8 – B-14	0	Figure C-15	0
C-1 – C-7	0	C-15-1	3
Figure C-1	9	C-16-1	6
C-1-1	9	Figure C-17	0
C-1-2	0	C-17-1	0
Figure C-2	8	Figure C-18 (Sheet 1 of 3)	7
C-2-1	2	Figure C-18 (Sheet 2 of 3)	0
Figure C-3 (Sheet 1 of 4)	3	Figure C-18 (Sheet 3 of 3)	0
Figure C-3 (Sheet 2 of 4)	3	C-18-1	0
Figure C-3 (Sheet 3 of 4)	6	C-18-2	6
Figure C-3 (Sheet 4 of 4)	4	C-18-3	2
C-3-1	2	C-18-4	9
C-3-2	6	Figure C-19	0
C-3-3	0	C-19-1	2
C-4-1	0	C-19-2	0
C-5-1	0	C-20-1	0
Figure C-6 (Sheet 1 of 3)	0	Figure C-21	0
Figure C-6 (Sheet 2 of 3)	0	C-21-1 and C-21-2	0
Figure C-6 (Sheet 3 of 3)	0	Figure C-22	0
C-6-1 and C-6-2	0	C-22-1	6
C-6-3	4	Figure C-23	0
Figure C-7	0	C-23-1	0
C-7-1	3	Figure C-24 (Sheet 1 of 2)	0
C-7-2	2	C-24-1	6
C-8 (Sheet 1 of 2)	0	I-1	3

*Zero in this column indicates an original page.

LIST OF EFFECTIVE PAGES (CON'T)

Page Number	*Change Number	Page Number	*Change Number
I-2	6	I-27	3
I-3	6	I-28 - I-32	6
I-4	4	I-33	3
I-5	6	I-34	6
I-6	6	I-35	2
I-7	0	I-36 blank	0
I-8	3	D-1	0
I-9	0	D-2	5
I-10	2	D-3	2
I-11 and I-12	0	D-4 blank	0
I-13	6	E-1	0
I-14	4	E-2 blank	0
I-15	2	F-1	0
I-16	0	F-2 blank	0
I-17	3	Glossary 1 - Glossary 5	0
I-18	0	Glossary 6 blank	0
I-19	4	Index 1 - Index 4	0
I-20	0	Index 5	5
I-21	3	Index 6 blank	0
I-22	0	FP-1	0
I-23	2	FP-2 blank	0
I-24 - I-26	0		

*Zero in this column indicates an original page.

TECHNICAL MANUAL
 NO. 55-1680-320-23 & P

HEADQUARTERS
 DEPARTMENT OF THE ARMY
 WASHINGTON, D.C., 22 August 1989

AVIATION UNIT AND INTERMEDIATE MAINTENANCE
 (Including Repair Parts and Special Tools List)
 HIGH PERFORMANCE RESCUE
 HOIST ASSEMBLY
 PART NUMBER 42305R1
 NSN 1680-01-058-3671

REPORTING ERRORS AND RECOMMENDING IMPROVEMENTS

You can help improve this manual. If you find any mistakes or if you know of a way to improve the procedures, please let us know. Mail your letter or DA Form 2028 (Recommended Changes to Publications and Blank Forms) or DA Form 2028-2 located in the back of this manual directly to: Commander, US Army Aviation and Missile Command, ATTN: AMSAM-MMC-MA-NP, Redstone Arsenal, AL 35898-5230. You may also submit your recommended changes by E-Mail directly to 2028@redstone.army.mil or by fax (256) 842-6546/DSN 788-6546. A reply will be furnished directly to you. Instruction for sending an electronic 2028 may be found at the back of this manual immediately preceding the hard copy 2028.

TABLE OF CONTENTS

<u>Chapter/Section</u>	<u>Title</u>	<u>Page</u>
CHAPTER 1	INTRODUCTION AND RESCUE HOIST-GENERAL	1-1
Section I	General Information	1-1
II	Equipment Description and Data	1-2
III	Technical Principles of Operations	1-7
IV	Salt Water Operations	1-13
CHAPTER 2	AVIATION UNIT MAINTENANCE INSTRUCTIONS	2-1
Section I	Repair Parts, Special Tools: Test, Measurement, and Diagnostic Equipment (TMDE): and Support Equipment	2-1
II	Service Upon Receipt	2-2
Task 2-4.	Service Upon Receipt of Material	2-2
Task 2-5.	Installation Instructions	2-4
Task 2-6.	Preliminary Servicing of Equipment	2-6
Task 2-7.	Operational Performance Check	2-8
III	Preventive Maintenance Checks and Services (PMCS)	2-14
IV	Troubleshooting	2-20

DISTRIBUTION STATEMENT A: Approved for public release; distribution is unlimited.

TABLE OF CONTENTS (cont)

<u>Chapter/Section</u>	<u>Title</u>	<u>Page</u>
Section V	Maintenance Procedures	2-39
	Rescue Hoist-Group 00	
	Rescue Hoist	
	Task 2-11. Inspect	2-39
	Task 2-12. Test	2-42
	Task 2-13. Service	2-43
	Task 2-14. Repair	2-44
	Control Pendant Assembly-Group 01	
	Control Pendant Assembly	
	Task 2-15. Inspect	2-45
	Task 2-16. Replace	2-46
	Boom Head Assembly-Group 02	
	Boom Head Assembly	
	Task 2-17. Inspect	2-48
	Task 2-18. Service	2-49
	Task 2-19. Repair	2-51
	Task 2-20. Replace	2-58
	Cable Cutter Assembly	
	Task 2-21. Inspect	2-61
	Task 2-22. Replace	2-62
	Task 2-22A. Repair	2-63
	Actuator Assembly (Up Limit)	
	Task 2-23. Inspect	2-64.2
	Task 2-24. Adjust	2-65
	Task 2-25. Replace	2-66
	Microswitch Assembly (FM Up)	
	Task 2-26. Test	2-67
	Control Panel Assembly-Group 03	
	Control Panel Assembly	
	Task 2-27. Replace	2-68
	Boom Position Support Assembly-Group 04	
	Boom Position Support Assembly	
	Task 2-28. Inspect	2-70
	Task 2-29. Adjust	2-71
	Task 2-30. Repair	2-75

TABLE OF CONTENTS (cont)

<u>Chapter/Section</u>	<u>Title</u>	<u>Page</u>
Section V (cont)	Boom Position Support Assembly-Group 04 (cont)	
	Height Adjuster Assembly	
	Task 2-31. Inspect	2-78
	Task 2-32. Repair	2-79
	Task 2-33. Replace	2-82
	Quick Disconnect (Upper Support)	
	Task 2-34. Inspect	2-83
	Task 2-35. Replace	2-84
	Upper Support Assembly	
	Task 2-36. Inspect	2-85
	Task 2-37. Repair	2-86
	Lower Support Assembly	
	Task 2-38. Inspect	2-87
	Task 2-39. Repair	2-88
	Reaction Arm Assembly	
	Task 2-40. Inspect	2-89
	Task 2-41. Replace	2-90
	Quick Disconnect (Reaction Arm)	
	Task 2-42. Inspect	2-91
	Task 2-43. Replace	2-92
	Winch Assembly-Group 05	
	Winch Assembly	
	Task 2-44. Inspect	2-93
	Task 2-45. Service	2-94
	Task 2-46. Adjust	2-96
	Task 2-47. Align	2-97
	Task 2-48. Repair	2-98
	Electric Motor	
	Task 2-49. Inspect	2-105
	Task 2-50. Replace	2-106
	Inertia Dump Assembly	
	Task 2-51. Inspect	2-108
	Task 2-52. Replace	2-109
	Limit Switch Drive Assembly	
	Task 2-53. Inspect	2-111
	Task 2-54. Adjust	2-112
	Task 2-55. Replace	2-116

TABLE OF CONTENTS (cont)

<u>Chapter/Section</u>	<u>Title</u>	<u>Page</u>
Section V (cont)	Winch Assembly-Group 05 (cont)	
	Cable Hook Assembly	
	Task 2-56. Inspect	2-118
	Task 2-57. Repair	2-120
	Task 2-58. Replace	2-123
	Hoist Cable Assembly	
	Task 2-59. Inspect	2-125
	Task 2-60. Replace	2-126
	Level Wind Shoe	
	Task 2-61. Inspect	2-130
	Task 2-62. Replace	2-131
	Drum Assembly	
	Task 2-63. Inspect	2-134
	Task 2-64. Align	2-135
	Electrical Cables and Connectors-Group 06	
	Electrical Cables and Connectors	
	Task 2-65. Inspect	2-139
	Task 2-66. Repair	2-140
	Task 2-67. Replace	2-141
Section VI	Preparation for Storage or Shipment	2-145
CHAPTER 3	AVIATION INTERMEDIATE MAINTENANCE-	3-1
	MAINTENANCE INSTRUCTIONS	
Section I	Replace Parts, Special Tools: Test, Measurement, and	3-1
	Diagnostic Equipment (TMDE); and Support Equipment	
Section II	Service Upon Receipt	3-2
	Task 3-4. Service Upon Receipt of Material	3-2
	Task 3-5. Installation Instruction	3-4
	Task 3-6. Preliminary Servicing of Equipment	3-6
	Task 3-7. Operational Performance check	3-8
Section III	Preventive Maintenance Checks and Services (PMCS)	3-14
Section IV	Troubleshooting	3-20
Section V	Maintenance Procedures	3-40
	Rescue Hoist-Group 00	
	Rescue Hoist	
	Task 3-11. Adjust	3-41
	Task 3-12. Repair	3-44

<u>Chapter/Section</u>	<u>TABLE OF CONTENTS (cont)</u>	<u>Page</u>
	<u>Title</u>	
Section V (cont)	Control Pendant Assembly-Group 01	
	Control Pendant Assembly	
	Task 3-13. Repair	3-45
	Boom Head Assembly-Group 02	
	Boom Head Assembly	
	Task 3-14. Adjust	3-52
	Task 3-15. Repair	3-53
	Brake Assembly	
	Task 3-16. Inspect	3-66
	Task 3-17. Repair	3-67
	Task 3-18. Adjust	3-70
	Task 3-19. Replace	3-72
	Clutch Assembly	
	Task 3-20. Inspect	3-74
	Task 3-21. Repair	3-75
	Task 3-22. Adjust	3-78
	Task 3-23. Replace	3-80
	Microswitch Assembly (Full Up)	
	Task 3-24. Replace	3-83
	Flexible Shaft Assembly	
	Task 3-25. Inspect	3-89
	Task 3-26. Replace	3-90
	Control Panel Assembly-Group 03	
	Control Panel Assembly	
	Task 3-27. Repair	3-92
	Blower Assembly / DC Motor	
	Task 3-28. Replace	3-93
	Boom Position Support Assembly-Group 04	
	Boom Position Support Assembly	
	Task 3-29. Repair	3-95
	Task 3-30. Replace	3-103
	Upper Support Assembly	
	Task 3-31. Replace	3-104

TABLE OF CONTENTS (cont)

<u>Chapter/Section</u>	<u>Title</u>	<u>P a g e</u>
Section V (cont)	Boom Position Support Assembly-Group 04 (cont)	
	Lower Support Assembly	
	Task 3-32. Repair	3-106
	Task 3-33. Replace	3-107
	Flexible Wiring Harness	
	Task 3-34. Inspect	3-108
	Task 3-35. Replace3-109
	Winch Assembly-Group 05	
	Winch Assembly	
	Task 3-36. Repair	3-114
	Task 3-37. Replace	3-125
	Limit Switch Drive Assembly	
	Task 3-38. Repair	3-127
	Task 3-39. Test	3-136
	Automatic Brake Assembly	
	Task 3-40. Inspect	3-138
	Task 3-41. Adjust	3-139
	Task 3-42. Repair	3-142
	Task 3-43. Replace	3-148
	Electrical Cables and Connectors-Group 06	
	Electrical Cables and Connectors	
	Task 3-44. Repair	3-150
	Task 3-45. Replace	3-151
Section VI	Preparation for Storage or Shipment	3-152

TABLE OF CONTENTS (cont)

<u>Chapter/Section</u>	<u>Title</u>	<u>Page</u>
APPENDIX A	REFERENCE	A-1
APPENDIX B	MAINTENANCE ALLOCATION CHART (MAC)	B-1
APPENDIX C	REPAIR PARTS AND SPECIAL TOOLS LIST	C-1
APPENDIX D	EXPENDABLE SUPPLIES AND MATERIALS LIST	D-1
APPENDIX E	TORQUE LIMITS	E-1
APPENDIX F	TEST EQUIPMENT LIST	F-1
	ALPHABICAL INDEX	Index 1

How to Use This Manual

1. Description of the Manual.

a. **Chapter Organization** This manual has three chapters and five appendices. Each chapter is divided into sections. In Chapter 1, each section is divided into descriptive paragraphs. These paragraphs have specific information about the unit and its major subcomponents. Chapters 2 and 3 are divided into maintenance tasks. These tasks tell you what you'll need for, and how to accomplish any job.

b. **Paragraph and Task Numbering** All paragraphs and tasks are numbered. This helps you find what you need when you need it. USE THE TABLE OF CONTENTS OR INDEX TO FIND THE PARAGRAPH OR TASK YOU NEED. Tasks and tables are identified by the number of the chapter in which it appears, followed by a dash and a number indicating the sequence in which it appears in the chapter.

Examples: Table 1-2 is the second table in Chapter 1.
 Task 2-11 is the eleventh task in Chapter 2.

c. **Appendix.** The appendices contain general information as well as all illustrated parts breakdowns. They list references, the maintenance allocation chart, repair parts and special tools, expendable supplies and materials, wiring diagrams, and test equipment,

2. Chapter 1 . Introduction. Chapter 1 provides an introduction to the rescue hoist, and is divided into three sections as follows:

a. **Section I - General Information.** This section provides general information on this manual and its corresponding maintenance forms and reports. Instructions are provided for destruction of the manual and reporting Equipment Improvement Recommendations (EIR).

b. **Section II - Equipment Description and Data.** This section describes rescue hoist capabilities, characteristics and features. It provides basic equipment data and shows the location of major hoist components.

c. **Section III - Technical Principles of Operations.** This section provides a description of the overall hoist operation, as well as that of the hoists major subassemblies.

3. Chapters 2 and 3- Maintenance Instructions.

a. Chapter 2 contains Aviation Unit Maintenance (AVUM) level tasks. Chapter 3 contains Aviation Intermediate Maintenance (AVIM) level tasks, Tasks are organized in a logical disassembly / assembly sequence and address only the component or assembly to be replaced. Locator illustrations are included for removal, installation and other procedures. They show you the area of the hoist to be worked on. Parts involved in the task are called out.

b. Initial setup is the first part of every task It lists what tools, materials and parts you will need before you can do the task. The following headings are used

(1) Task Title. The task title after the paragraph number describes the job to be done in the task.

(2) Personnel Required. The people needed to do the task are listed under this heading. They are identified by their MOS. When more than one of any MOS is needed, the number needed is shown in parentheses. The text will tell you when an assistant is needed.

(3) Parts / Materials. All mandatory replacement parts are listed, including gaskets, packings, cotter pins and lockwashers. They are listed by the Repair Parts and Special Tools List (RPSTL) name and identified by part number. Expendable supplies and support materials are listed, including solvent, rags, grease and safety wire. They are listed in Appendix D, and the item number follows the supply / material name in parenthesis;

Example: Loctite Compound (item 37, App. D)

(4) Tools and Test Equipment. Tools, tool kits or shop sets needed to do the task are listed here. If tools from your repairman's kit are needed the kit is listed. Tools you need that are not in the kit or set, are listed by name, type and size. Special tools and test support equipment are listed by part number. Find these items in Appendix F.

(5) Equipment Condition. All the things to be done before you start the task are listed under this heading. To help, the number of the condition task is listed under Equipment Condition Para.

(6) References. Related TM's that you will need to accomplish the task are listed under this heading. The task steps tell you when these TM's are needed.

4. Appendices.

a. **Appendix A - References.** This appendix lists all referenced publications needed to perform the maintenance procedures in this manual.

b. **Appendix B - Maintenance Allocation Chart (MAC).** This appendix consists of four sections as follows:

(1) Section I - Introduction. This section is a summary of what is in the MAC,

(2) Section II. This section is the MAC. The MAC assigns maintenance functions in accordance with the Three Levels of Maintenance concept for Army Aviation. Refer to Appendix B for an explanation of MAC columns.

(3) Section III - Tool and Test Equipment Requirements, This section consists of five columns. Refer to Appendix B for explanation of columns.

(4) Section IV - Remarks. This section has two columns, containing the following information:

(a) Reference Code. This column contains alphabetical codes or numbers in parentheses corresponding to the codes appearing in the applicable columns in the MAC,

(b) Remaks/Notes. This column contains the actual notes as referenced by the reference codes to the MAC,

c. **Appendix C - Repair Parts and Special Tools List.** This appendix contains information on the repair parts and special tools utilized in the maintenance of the rescue hoist. It is divided into four sections as follows:

(1) Section I - Introduction. This section is a summary of what is in the RPSTL.

(2) Section II - Repair Parts List. This section is the Repair Parts List and has six columns. Refer to the Explanation of Columns in Appendix C (sections II and III) for column identification.

(3) Section III - Special Tools List. This section lists special tools, TMDE, and other support equipment authorized for rescue hoist maintenance. Refer to the Explanation of Columns in Appendix C (sections II and III).

(4) Section IV - National Stock Number and Part Number Index. This is a list of all National Stock Numbers (NSN). The NSN numbers are cross referenced to the Repair Parts List Figure and item numbers. The NSN list is followed by a Part Number index, arranged in alpha-numerical order and cross referenced to the NSN. Refer to the Explanation of Columns in Appendix C (section IV).

d. **Appendix D - Expendable Supplies and Materials List.** This appendix consists of two sections as follows:

(1) Section I - Introduction. This section is a summary of what is in the Expendable Supplies and Materials List. -

(2) Section II - This section is the Expendable Supplies and Materials List and has four columns. Refer to Appendix D for an explanation of columns.

e. **Appendix E - Torque Limits.** This appendix provides standard torque limits for general type screws, nuts, bolts, fitting and coupling nuts.

f. **Appendix F - Test Equipment List.** This appendix lists unique test equipment utilized in rescue hoist maintenance. -

5. **Glossary.** Definitions of abbreviations and unusual terms you find in the manual are listed here to help you,

6. **Index.** This appears at the end of the manual. It lists all subjects in the manual by alphabetical order and the entries are in everyday language of the user. This index contains many possible ways of locating the subject, i.e., pressure fluid filter; fuel inlet filter filter, fuel; filter, pressure fluid. This is necessary since the official nomenclature is not always readily recognized by the user.

7. How To Fix a Rescue Hoist Malfunction.

a. **Determining the Cause.** Figuring out the cause of the malfunction, troubleshooting, is the first step in fixing the hoist and returning it to operation. Follow these simple steps to determine the root of your problem:

(1) Turn to the Table of Contents section in this manual (page i).

(2) Locate "Section IV - Troubleshooting" and turn to the page indicated. For AVUM troubleshooting, turn to page 2-20. For AVIM troubleshooting, turn to page 3-20. We'll be using AVUM for our example.

(3) In the Symptom Index (Table 2-2), find the heading for the component affected by the malfunction. We'll use "Winch Assembly" for our example.

(4) Determine which of the symptoms under "Winch Assembly" best describes the problem you've encountered. Let's say that when you're operating the hoist at minimum speed, the cable is reeling at 22 rpm. The closest symptom is "Cable speed - exceeds 15 rpm".

(5) Look across the column in Table 2-2 to find the matching Troubleshooting Procedure. In this case it's procedure 9. Turn to that procedure (page 2-29).

(6) Begin troubleshooting procedure 9 at the box marked START. Carefully work your way through the troubleshooting tree to try to determine what the problem is. Let's say that you're sure the hoist switch is OK and you don't find any oil leaks. Upon inspection, the winch electric motor appears damaged. If that's the case, we'll want to replace the motor.

(7) To replace the winch electric motor, Procedure 9 tells us to go to Task 2-50. Task number and description are located on the top of each page in Chapters 2 and 3. In our case, we'll turn to page 2-106.

b. **Preparing for a Task.**

NOTE

You must familiarize yourself with the entire maintenance procedure before beginning any maintenance task. Ensure all parts materials and tools are handy. Read through all steps before beginning.

(1) Read the initial setup carefully before starting. It tells you what you will need and what you have to know to start the task. **DO NOT START A TASK UNTIL:**

You know what is needed

You have the things you need

You understand what to do.

(2) If an expendable material has an item number after is, go to the Expendable Supplies and Materials List in Appendix D. Read down the Item Number column to your number. This is the expendable you need for your task.

(3) If parts are listed they can be drawn from tech supply. Before you start the task, check and make sure you can get the needed parts; National Stock Numbers (NSN) and part numbers are listed in Appendix C.

(4) check for personnel required

(5) If preliminary procedures are listed under "Equipment Conditions", **BE SURE THE LISTED TASKS ARE DONE;** then do this task.

c. **How To Do The Task.** Before starting, read the entire task. Familiarize yourself with the entire procedure before you begin the task. As you read, remember the following:

(1) **PAY ATTENTION TO WARNINGS, CAUTIONS AND NOTES.**

(2) When values are in bold type, an inspector must OK this value before continuing with the next step. ■

(3) A GLOSSARY is provided at the rear of the manual. It lists the sped words and unusual terms used in this manual and gives their meaning. Check it out. It may help you understand the instructions.

(4) The following are considered standard maintenance practices. Instructions about these practices will not normally be included in task steps. Task steps will tell you when standard maintenance practices do not apply.

(a) Electrical wiring will be tagged before they are disconnected.

(b) Used preformed packings, retainers, gaskets, cotter pins, lockwashers, etc. are discarded. New parts shall be installed.

(c) Packings are coated before installation in accordance with the task instructions.

(d) Disassembly procedures reflect disassembly needed to support total authorized repair. You may not need to disassemble a part as far as described in the task Follow the steps to disassemble as far a needed to repair/replace worn or damaged parts.

(e) Before a component or the disassembled parts of a component are inspected, they are cleaned as required.

- (f) Components and mating surface area will be inspected for serviceable condition before installation.
- (g) Guide lines will be used when any item is hoisted overhead.
- (h) When a nut is tightened or loosened on a bolt, the bolt head will be held with a wrench
- (i) A special torque will be cited when the words TORQUE TO are used. Standard torques are utilized at all other times.

(j) When torquing hardware, observe compliance with drag torque as required. To determine drag torque, thread nut onto screw or bolt until at least two threads protrude. The nut shall not contact the mating part. The torque necessary to begin turning the nut is the drag torque.

(k) Appendix E provides standard torque limits for general type screws, nuts, bolts, fittings and coupling nuts. These standard torque values apply only when special torque values are not specified in procedures. Included in the torque tables are the applicable torque wrenches.

(l) If additional setup tools are required such as crowfoot wrenches, they will be listed in the task INITIAL SETUP.

(m) When cotter pin is required, cotter pinholes will be aligned within allowable torque range.

(n) Following installation, paint will be touched up as required.

(o) Following maintenance, inspect for foreign objects.

(5) General maintenance procedures (e.g. “replace studs and inserts”) are not included in the maintenance instructions. A reference is made to General Aircraft Maintenance Manual (TM 1-1500-204-23, Series) for these procedures.

CHAPTER 1 INTRODUCTION AND RESCUE HOIST – GENERAL

Section I. GENERAL INFORMATION

1-1. Scope.

Type of Manual: Aviation Unit and Intermediate Maintenance

Part Number and
Equipment Name: 42305R1 High Performance Rescue Hoist Assembly

Purpose of Equipment: Primary function of the rescue hoist is personnel rescue work conducted by helicopters.

1-2. Maintenance. Department of the Army forms, records and reporting procedures used for equipment maintenance will be those prescribed by DA PAM 738-751, Functional Users Manual for the Army Maintenance Management System - Aviation (TAMMS-A).

1-3. Calibration. There are no calibration requirements for the rescue hoist. Refer to individual component tasks for sub-assembly adjustments, checks and tests.

1-4. Destruction of Army Material to Prevent Enemy Use.

NOTE

Decision to destroy a rescue hoist shall be made by appropriate authority.

Procedure for destroying Army material to prevent use by enemy are listed in TM 750-244-2-5.

1-5. Reporting Equipment Improvement Recommendations (EIR). If your rescue hoist needs improvement, let us know. Send us an EIR. You, the user, are the only one who can tell us what you don't like about your equipment. Let us know why you do not like the design. Put it on a SF-368 Quality Deficiency Report (QDR). Mail it to us at:

Commander USAAMCOM
ATTN: AMSAM-MMC-RE-F
Redstone Arsenal, AL 35898

We will send you a reply.

Section II. EQUIPMENT DESCRIPTION AND DATA

1-6. Equipment Characteristics, Capabilities, and Features.

a. Characteristics.

- . Personnel rescue work
- . Electrically powered with standard 28 vdc
- . Helicopter mounted (all UH1 and UH-60 series helicopters)
- . Built in limit switches regulate cable extension and retraction to prevent malfunction
- . Motor equipped with thermal protector to prevent operation if overheating
- . Quick disconnect adapters allow for easy installation and removal
- . Height and length adjusters for installation in all UH1 helicopters

b. Capabilities and Features.

- . 600 pound rated load (272.4 kg)
- . 1,800 pound limited load (817.2 kg)
- . 250 ft./min. (762 dm/min.) cable speed with 300 lb. load (136.2 kg)
- . 250 ft. of useable cable
- . Operation controlled by pilot or hoist operator with hand held control pendant

1-7. Location and Description of Major Components (Figure 1-1).

A BOOMHEAD ASSEMBLY. Installed boomhead is designed to swivel 120 degrees about the boom cable axis, 60 degrees either side of center, to provide maximum flexibility.

B WINCH ASSEMBLY. Operates winding of cable assembly. Limit switches regulate rate, speed and length of operation.

C CONTROL PANEL ASSEMBLY. Provides electrical interface between the hoist, control pendant and input power supply. Contains operational PC boards.

D BOOM POSITION SUPPORT ASSEMBLY. Contains the boom position actuator, upper and lower support assemblies, flexible wiring harness and microswitches.

E CONTROL PENDANT. Contains BOOM IN/OUT and CABLE UP/DOWN switches, as well as a variable speed control to allow hand held hoist operation.

F CABLE HOOK ASSEMBLY. Secures various rescue equipment to the hoist cable.

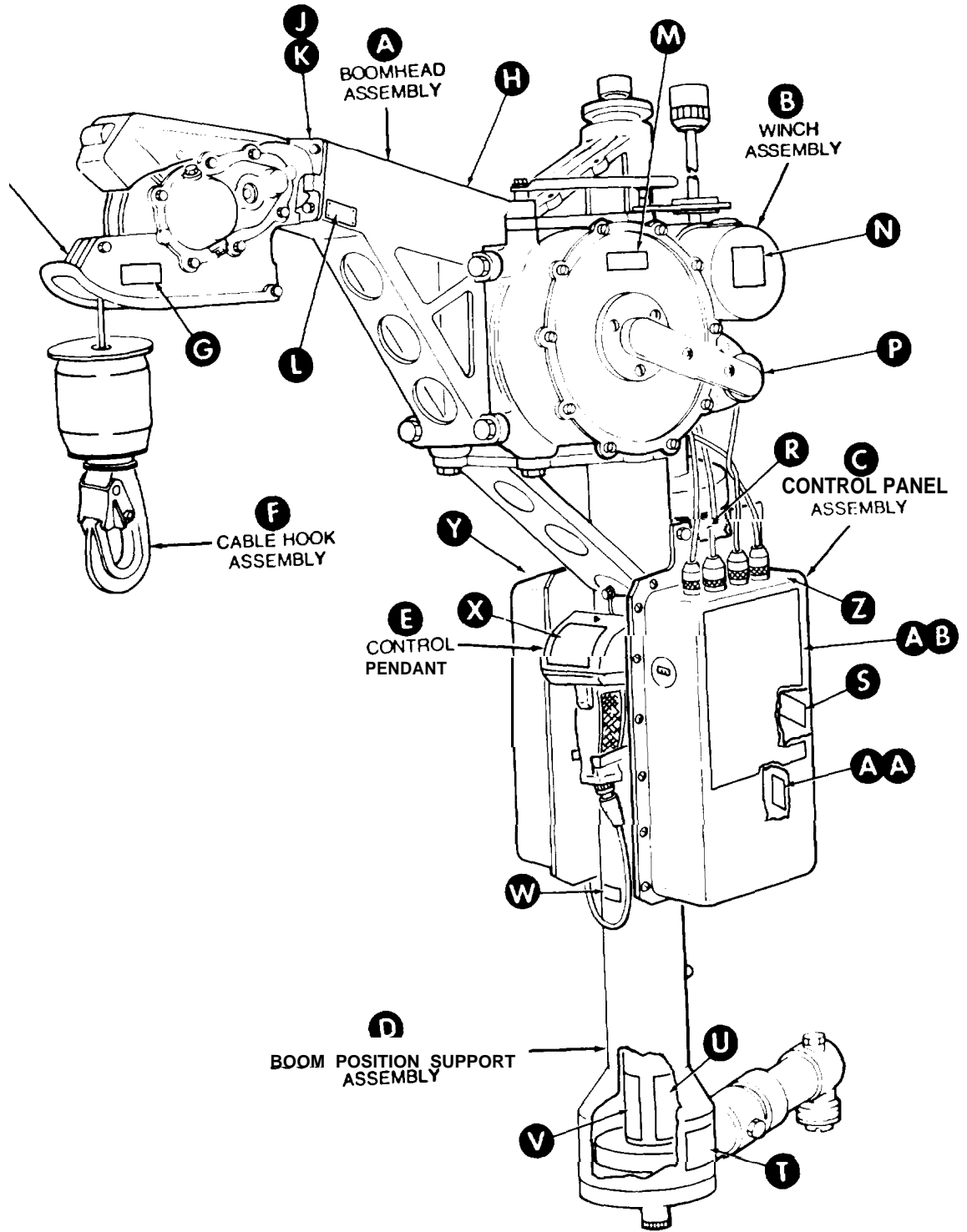


Figure I-1. Major Components /Instruction Plates(Sheet 1 of 4)

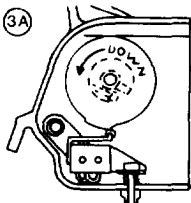
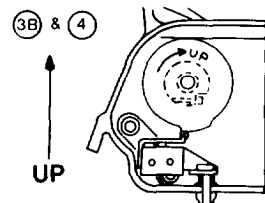
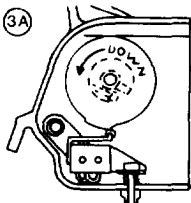
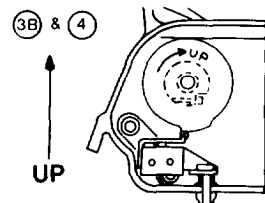
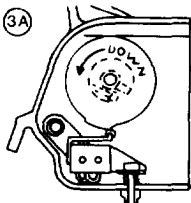
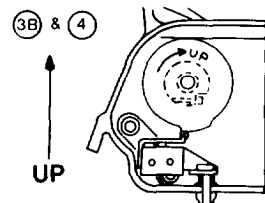
<p>G</p> <div style="border: 1px solid black; padding: 5px; margin-bottom: 5px;"> <p style="text-align: right; font-size: small;">82402-42305R300</p> <p style="text-align: center;">BOOM HEAD ASSEMBLY</p> <p>PN <input type="text" value="82402-42305R300"/> SER NO. <input type="text"/></p> <p>CONTR. NO. <input type="text" value="DAAJ01-78-C-0001"/> MFG DATE <input type="text"/></p> <p style="text-align: right;">U.S.</p> </div>	<p>H</p> <div style="border: 1px solid black; padding: 5px;"> <p style="text-align: right; font-size: small;">82402-42217C221</p> <p style="text-align: center;">FILL TO FULL MARK WITH AUTO TRANSMISSION FLUID DEXRON TYPE U.S. NATL STK</p> <p style="text-align: center;">NO. 9150-00-698-2382</p> <p style="text-align: center;">FOR OPN. BELOW -40 F DRAIN AND FILL WITH MIL-H-5606 OIL</p> </div>							
<p>J</p> <div style="border: 1px solid black; padding: 5px; margin-bottom: 5px;"> <p style="text-align: right; font-size: small;">82402-42305D30</p> <p style="text-align: center;">HIGH PERFORMANCE HOIST ASSEMBLY</p> <p>PN <input type="text" value="82402-42305R1"/> SER NO. <input type="text"/></p> <p>NSN <input type="text"/> MFG DATE <input type="text"/></p> <p>CONTR. NO. <input type="text" value="DAAJ01-78-C-0001"/></p> <p>RATED VOLTAGE 28 VOLTS D.C. RATED AMPERAGE 125 AMPS MAX U.S. PAT. NO. 4.046.235 --- 4.023.744 --- 4.030.353</p> <p style="text-align: right;">U.S.</p> </div>	<p>K</p> <div style="border: 1px solid black; padding: 5px; margin-bottom: 5px;"> <p style="text-align: right; font-size: small;">82402-42305C12</p> <p style="text-align: center;">THIS HOIST CONTAINS ASSEMBLIES COVERED BY THE FOLLOWING PATENTS:</p> <p style="text-align: center;">4,023,744 4,030,353 4,046,235</p> </div>	<p>L</p> <div style="border: 1px solid black; padding: 10px; text-align: center;"> <p>- WARNING -</p> <p>CARTRIDGE ACTIVATED CABLE CUTTER---DISCONNECT ELECTRICAL PLUG WHEN REPLACING CABLE OR PERFORMING MAINTENANCE ON UNIT</p> </div>						
<p>M</p> <div style="border: 1px solid black; padding: 5px; margin-bottom: 5px;"> <p style="text-align: right; font-size: small;">82402-42305C173</p> <p style="text-align: center;">WINCH ASSEMBLY</p> <p>PN <input type="text" value="82402-42305R100"/> SER NO. <input type="text"/></p> <p>CONTR. NO. <input type="text" value="DAAJ01-78-C-0001"/> MFG DATE <input type="text"/></p> <p>OPERATING CAPACITY <input type="text" value="600 LBS"/> U.S.</p> </div>	<p>P</p> <div style="border: 1px solid black; padding: 10px;"> <p style="text-align: center;">SWITCH CAM POSITION</p> <table style="width: 100%; border-collapse: collapse;"> <tr> <td style="width: 50%; text-align: center; vertical-align: top;"> <p>① ② & ③A</p>  <p>DOWN</p> <p>* SWITCH ADJUSTING SCREW</p> </td> <td style="width: 50%; text-align: center; vertical-align: top;"> <p>③B & ④</p>  <p>UP</p> <p>CAM ADJUSTING SCREW</p> </td> </tr> <tr> <td colspan="2" style="text-align: center; padding: 5px;"> <p>LOOSEN CAM ADJUSTING SCREWS TO ADJUST CAMS TO ACTUATE SWITCHES AT DESIRED CABLE LENGTHS AS REQUIRED</p> </td> </tr> <tr> <td style="vertical-align: top; padding: 5px;"> <p>DOWN ALL STOP DOWN LIMIT 240 FT DECEL - CAUTION 10 FT DECEL - CAUTION 1.0 FT FINAL DECEL</p> </td> <td style="vertical-align: top; padding: 5px;"> <p>*CAUTION: SWITCH ADJUSTING SCREWS ARE FACTORY ADJUSTED - DO NOT READJUST</p> </td> </tr> </table> <div style="text-align: right; font-size: small; margin-top: 10px;">82402-42305E225</div> </div>		<p>① ② & ③A</p>  <p>DOWN</p> <p>* SWITCH ADJUSTING SCREW</p>	<p>③B & ④</p>  <p>UP</p> <p>CAM ADJUSTING SCREW</p>	<p>LOOSEN CAM ADJUSTING SCREWS TO ADJUST CAMS TO ACTUATE SWITCHES AT DESIRED CABLE LENGTHS AS REQUIRED</p>		<p>DOWN ALL STOP DOWN LIMIT 240 FT DECEL - CAUTION 10 FT DECEL - CAUTION 1.0 FT FINAL DECEL</p>	<p>*CAUTION: SWITCH ADJUSTING SCREWS ARE FACTORY ADJUSTED - DO NOT READJUST</p>
<p>① ② & ③A</p>  <p>DOWN</p> <p>* SWITCH ADJUSTING SCREW</p>	<p>③B & ④</p>  <p>UP</p> <p>CAM ADJUSTING SCREW</p>							
<p>LOOSEN CAM ADJUSTING SCREWS TO ADJUST CAMS TO ACTUATE SWITCHES AT DESIRED CABLE LENGTHS AS REQUIRED</p>								
<p>DOWN ALL STOP DOWN LIMIT 240 FT DECEL - CAUTION 10 FT DECEL - CAUTION 1.0 FT FINAL DECEL</p>	<p>*CAUTION: SWITCH ADJUSTING SCREWS ARE FACTORY ADJUSTED - DO NOT READJUST</p>							
<p>N</p> <div style="border: 1px solid black; padding: 10px;"> <p style="text-align: center;">ELECTRIC DRIVE MOTOR</p> <p>PN 527KE3 SER. NO. <input type="text"/></p> <p>NSN <input type="text"/></p> <p>CONTR. NO. DAAJ01-78-C-0001</p> <p>CUST. NO. <input type="text"/></p> <p>VDC 28 AMP 110 HP 2.50</p> <p>ROT REV RPM 5250 OR 11000</p> <p>DUTY CONTINUOUS US</p> <p>WOUND SHUNT</p> <p style="text-align: center; font-size: small;">FOR USE ON 28VDC SYSTEM</p> </div>								

Figure 1-1. Major Components / Instruction Plates (Sheet 2 of 4)

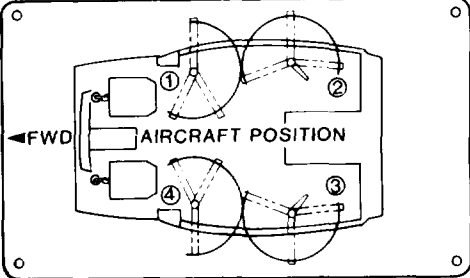
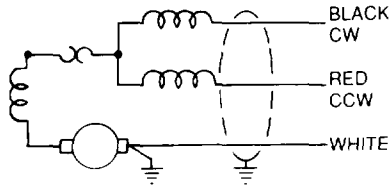
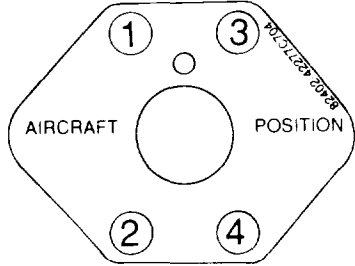
<p>R</p> <div style="border: 1px solid black; border-radius: 50%; padding: 10px; text-align: center;"> <p>6606P1 20P28 82402 149096</p> <p>FAN, VANEAXIAL</p> <p>PN 82402 FV3 4 SER NO. <input type="text"/></p> <p>CONT <input type="text"/> CFM 30</p> <p>NSN <input type="text"/> ROT CCW</p> <p>HP <input type="text"/> RPM 15000 AMP 2 5</p> <p>V 27 DUTY CONTINUOUS</p> <p><input type="text"/></p> <p>FOR USE ON 28 VDC SYSTEM U.S.</p> </div>	<p>S</p> <div style="border: 1px solid black; padding: 10px; text-align: center;"> <p>HIGH SPEED</p> <p>LOW SPEED</p> </div>	<p>T</p> <div style="border: 1px solid black; padding: 10px;">  <p>A diagram showing the internal mechanism of an aircraft position indicator. It features a central shaft with four contact points labeled 1, 2, 3, and 4. A lever on the left is labeled 'FWD'. The text 'AIRCRAFT POSITION' is centered above the mechanism.</p> </div>
<p>U</p> <div style="border: 1px solid black; padding: 10px;"> <p>ELECTRIC DRIVE MOTOR</p> <p>PN 239YC32 SER. NO. <input type="text"/></p> <p>NSN <input type="text"/></p> <p>CONTR. NO. <input type="text"/></p> <p>CUST. NO. <input type="text"/></p> <p>VDC 28 AMP 8 HP 0.1</p> <p>ROT REV RPM 10,000</p> <p>DUTY INTERMITTENT</p> <p>WOUND SPLIT-SERIES</p> <p>FOR USE ON 28VDC SYSTEM</p> </div>	<p>V</p> <div style="border: 1px solid black; padding: 10px;"> <p style="text-align: center;">SCHEMATIC DIAGRAM</p>  <p>A schematic diagram of an electric motor winding. It shows a series of coils connected to a power source. Three wires are labeled: 'BLACK CW', 'RED CCW', and 'WHITE'.</p> </div>	
<p>X</p> <div style="border: 1px solid black; padding: 10px; text-align: center;"> <p>124 06062P 20P28</p> <p>CONTROL PENDANT GRIP</p> <p>PN 82402 42305R300 SER NO. <input type="text"/></p> <p>U.S.</p> </div>	<p>Y</p> <div style="border: 1px solid black; padding: 10px; text-align: center;"> <p>HOIST POWER</p> </div>	<p>W</p> <div style="border: 1px solid black; padding: 10px;"> <p style="text-align: right;">P6606062P-20P28</p> <div style="border: 1px solid black; height: 20px; width: 100%;"></div> <p style="text-align: center;">BOOM POSITION ACTUATOR ASSEMBLY</p> <p>PN 82402-42305R500 SER NO. <input type="text"/></p> <p>CONTR. NO. DAAJ01-78-C-0001 MFG DATE <input type="text"/></p> <p style="text-align: right;">U.S.</p> </div>
<p>Z</p> <div style="border: 1px solid black; padding: 10px; text-align: center;">  <p>A diagram of a hexagonal control panel with a central circular hole. Four positions are marked with circled numbers 1, 2, 3, and 4. The text 'AIRCRAFT POSITION' is written across the panel. A part number '82402 42305R700' is visible on the right edge.</p> </div>	<p>AA</p> <div style="border: 1px solid black; padding: 10px;"> <div style="border: 1px solid black; height: 20px; width: 100%;"></div> <p style="text-align: center;">CONTROL PANEL</p> <p>PN 82402 ASSY42305R700 SER NO. <input type="text"/></p> <p>NSN <input type="text"/> MFG DATE <input type="text"/></p> <p>CONTRACT NO. DAAJ01 78 C 0001 U.S.</p> </div>	

Figure 1-1. Major Components / Instruction Plates (Sheet 3 of 4)

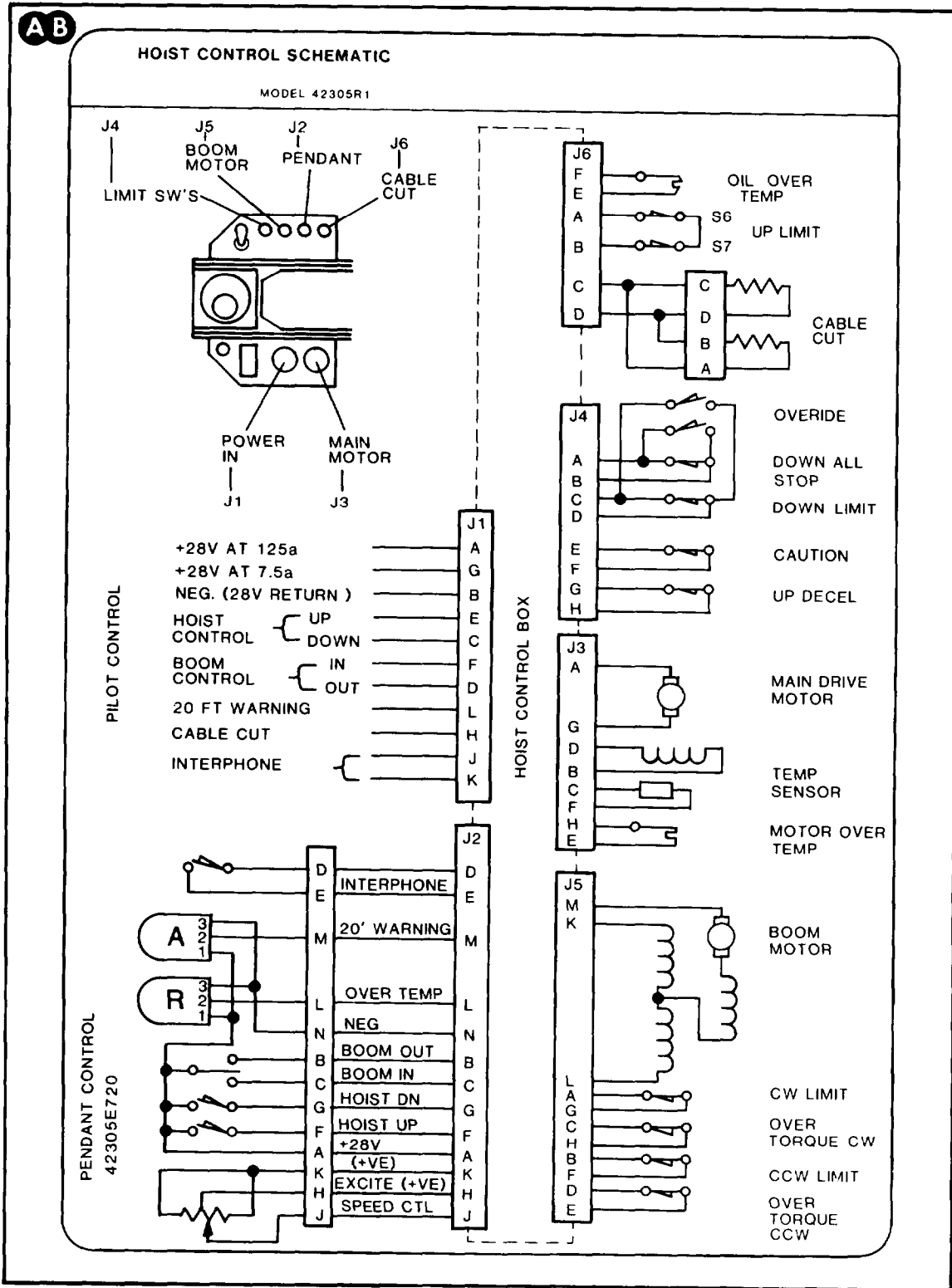


Figure 1-1, Major Components / Instruction Plates (Sheet 4 of 4)

1-8. Equipment Data.

Weight (wet)	180.0 lbs. (81.72 kg)
Height (min)	50.90 in. (129.28 cm)
(max)	51.91 in. (131.85 cm)
Length (min)	33.58 in. (85.29 cm)
(max)	35.38 in. (89.86 cm)
Width	13.50 in. (34.29 cm)
Power Input	125 amps max. @ 28 vdc
Rated Load	600 lbs. (272.40 kg)
Limit Load	1800 lbs. (817.20 kg)
Lubricating Oil (normal use)	NSN 9150-00-698-2382
(below .40°F (-40°C))	MIL-H.5606

1-9. Safety, Care, and Handling. Observe all general precautions and safety regulations when handling the rescue hoist.

Section III TECHNICAL PRINCIPLES OF OPERATION

1-10. Rescue Hoist Assembly. The Rescue hoist assembly (Figure 1-2) is intended for installation on all UH1 Series helicopters. The hoist is an electronically powered unit consisting of five major assemblies; winch assembly, boom head assembly, boom position support assembly, control panel assembly, and control pendant assembly. The hoist has a 260 foot (792.5 dm) cable and 600 pound (272.4 kg) rated load. Lift speed at rated load is 125 feet (381 dm) per minute (250 feet (762 dm) per minute at 300 pound (136.2 kg) load). The hoist uses aircraft power, and can be operated by one man.

1-11. Winch Assembly.

a. The winch assembly (Figure 1-3) consists of a winch mechanism, limit switch drive assembly, electric motor, brake cooling pump, automatic clutch and brake assembly, inertia dump assembly, and the cable hook.

b. The limit switch drive assembly contains four positive action limit switches that control extension and retraction rates of the rescue cable. One limit switch prevents extension (unreeling) of the cable beyond established limits. A second switch operates when the cable reaches 3 to 5 safety wraps from full reel off (down limits at 250 (762 dm) foot maximum extension). A third switch operates the rewind (reeling) caution indicator, decelerating the hoist to 50% speed when the cable hook is with 10 feet (30.48 dm) of full stowed position. The fourth limit switch operates the hoist when the cable hook reaches 18 inches from full stow (decelerating to 12 feet (36.58 dm) per minute).

c. The automatic brake and clutch assemblies actuate to prevent reeling or extension of the cable when maximum load is exceeded Two thermal temperature sensing switches monitor winch and brake operation, actuating when system components exceed safe temperature limits. The brake cooling pump acts to regulate brake and clutch operating temperatures.

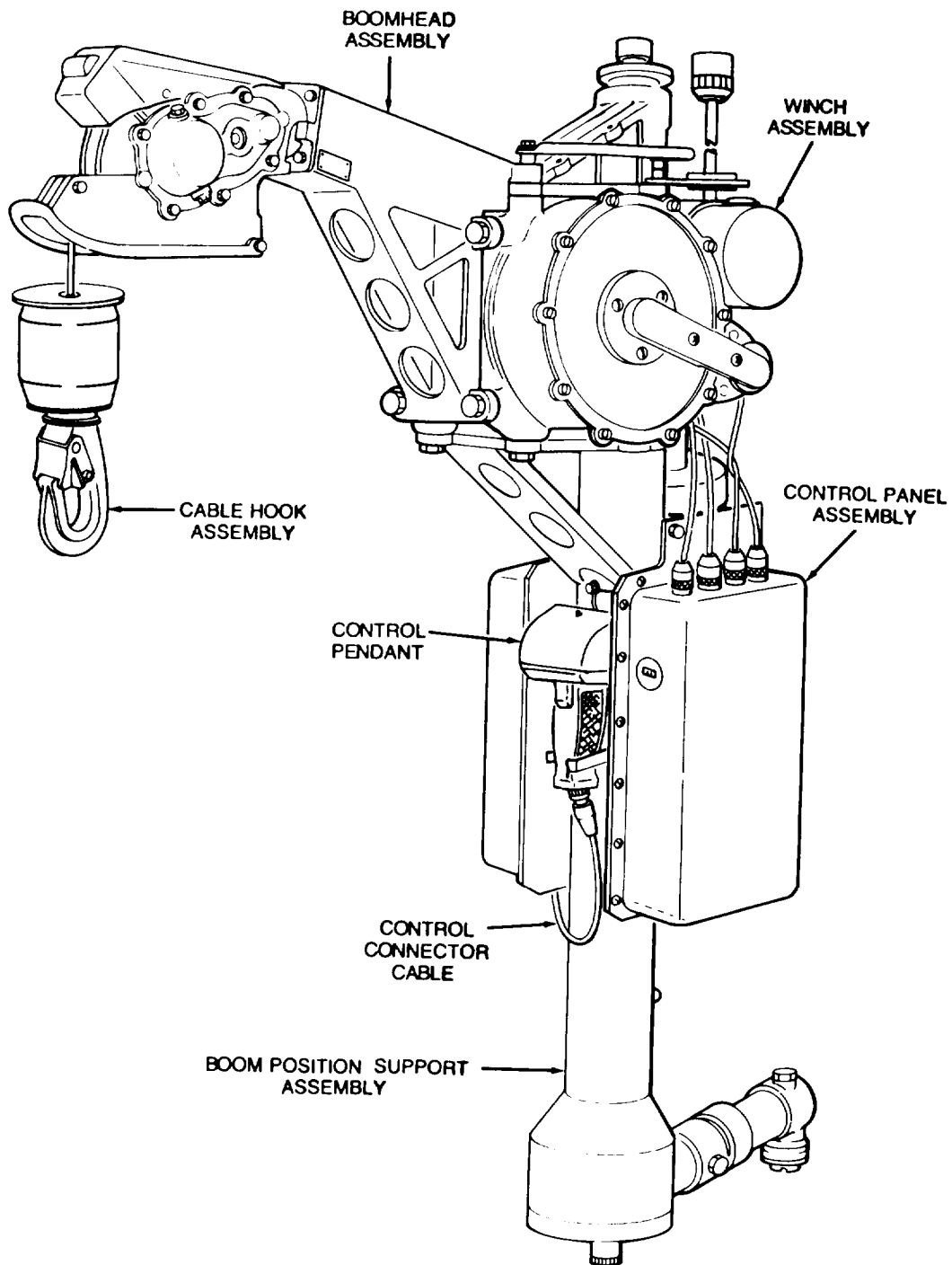


Figure 1-2. Rescue Hoist Assembly

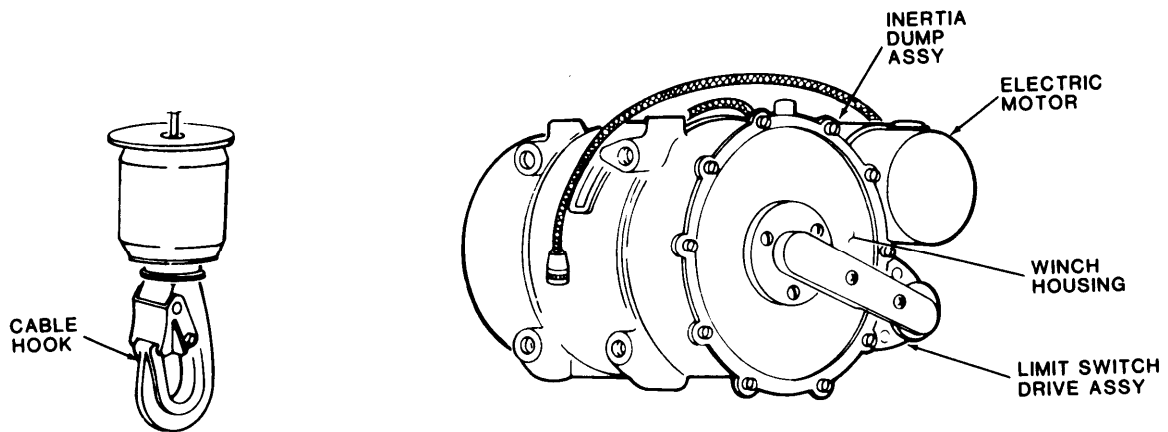


Figure 1-3. Winch Assembly

1-12. Boom Head Assembly.

a. The boom head assembly (Figure 1-4) consists of a boom assembly, sheave assembly, dual up-limit switches, cable roller and guide, brake and clutch assemblies, cable cutter, and two electrical harness assemblies.

b. The boom head is designed to swivel 120 degrees about the boom cable axis, 60 degrees either side of center. The cable roller assembly and cable guide ensure smooth extension/rewind of the hoist cable. The cable cutter assembly enables shearing of the cable in emergency situations. Electrical harness assemblies provide electrical power and signals from the control panel.

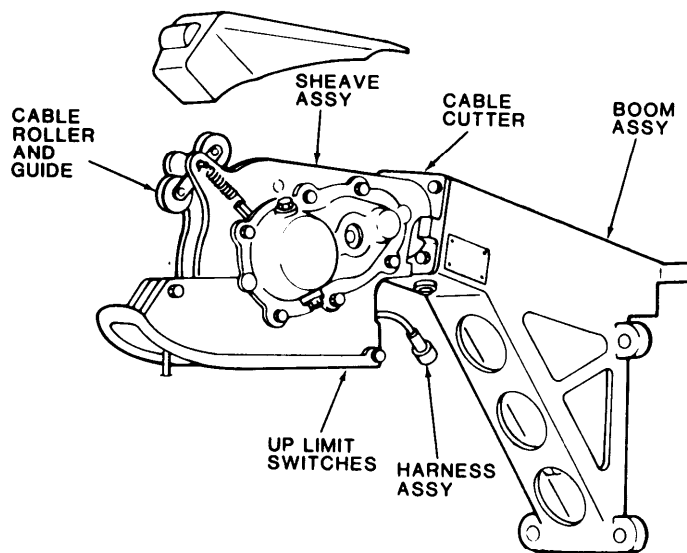


Figure 1-4. Boom Head Assembly

1-13. Boom Position Support Assembly.

a. The boom position support assembly (Figure 1-5) consists of upper and lower support assemblies, a height adjuster assembly, four limit switches, boom position motor, gear drive assembly, a mechanical stop assembly, reaction arm, and the rotary actuator.

b. The boom position rotary actuator swivels the boom head assembly, positioning the cable hook for proper operation. The actuators maximum operating load is 6500 in.lbs. (734.5 N.m), with a 205 degree operational range. Limit switches prevent operation when maximum operating load is exceeded.

c. Rotation is powered by the boom position motor and gear drive assembly. The mechanical stop assembly regulates to prevent rotation beyond the 205 degree range. Hoist positioning can be adjusted through actuation of the height adjuster or reaction arm assemblies.

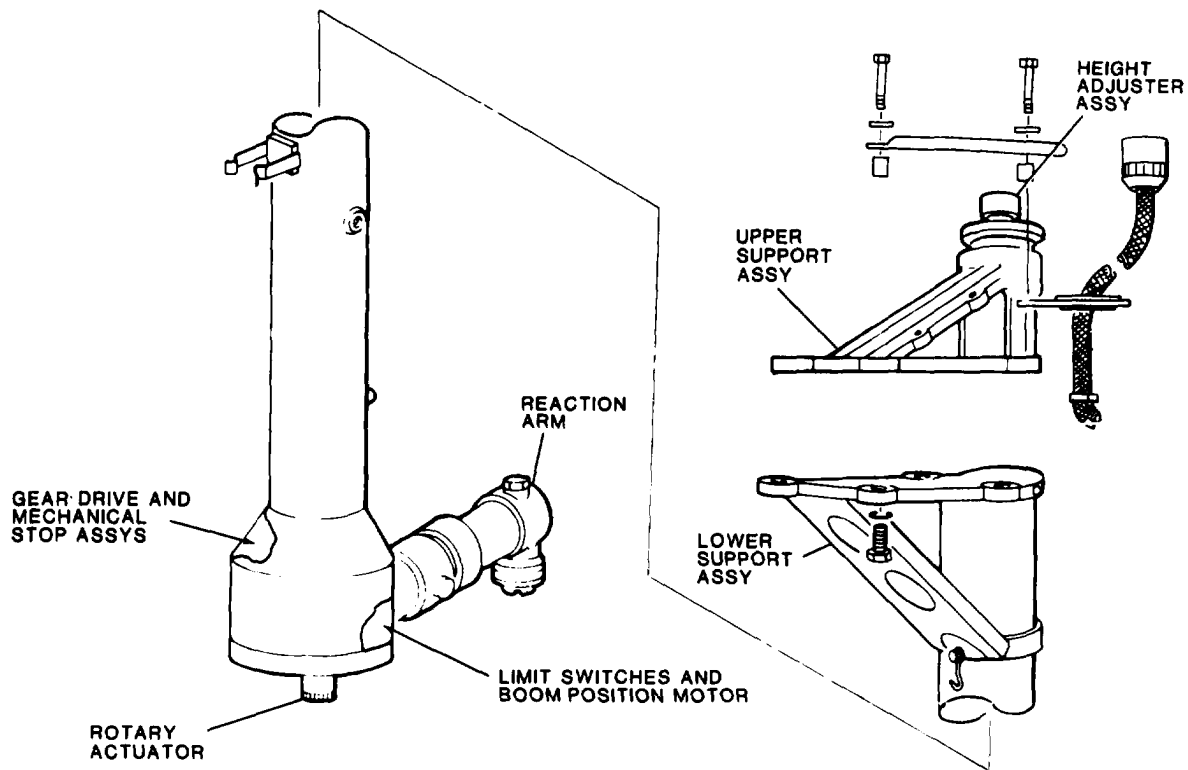


Figure 1-5. Boom Position Support Assembly

1-14. Control Panel Assembly.

a. The control panel assembly (Figure 1-6) provides electrical interface through the hoist. Electrical connectors provide input (through harness assemblies) to the control pendant, limit switch drive assembly, boom position motor, boom head assembly and winch motor.

b. Operational switches are mounted to the top of the panel and control electrical actuation to components. Panel lights indicate power status. Power supply, logic and operational printed circuit boards are housed within the panel. A fan blower assembly, operated by a DC motor, maintains climate variances within the control panel.

1-15. Control Pendant Assembly.

a. The control pendant assembly (Figure 1-6) is a pistol-grip control that allows remote operation of the rescue hoist. BOOM IN/OUT and CABLE UP/DOWN switches, a variable speed control, and a trigger operated ON/OFF switch are mounted on the pendant.

b. Pendant mounted lights indicate operational status. The trigger ON/OFF switch allows intercommunication between the hoist operator and other crew member.

1-16. Electrical System. Refer to Figure FO-1, located in back of manual, for the rescue hoist electrical system schematic.

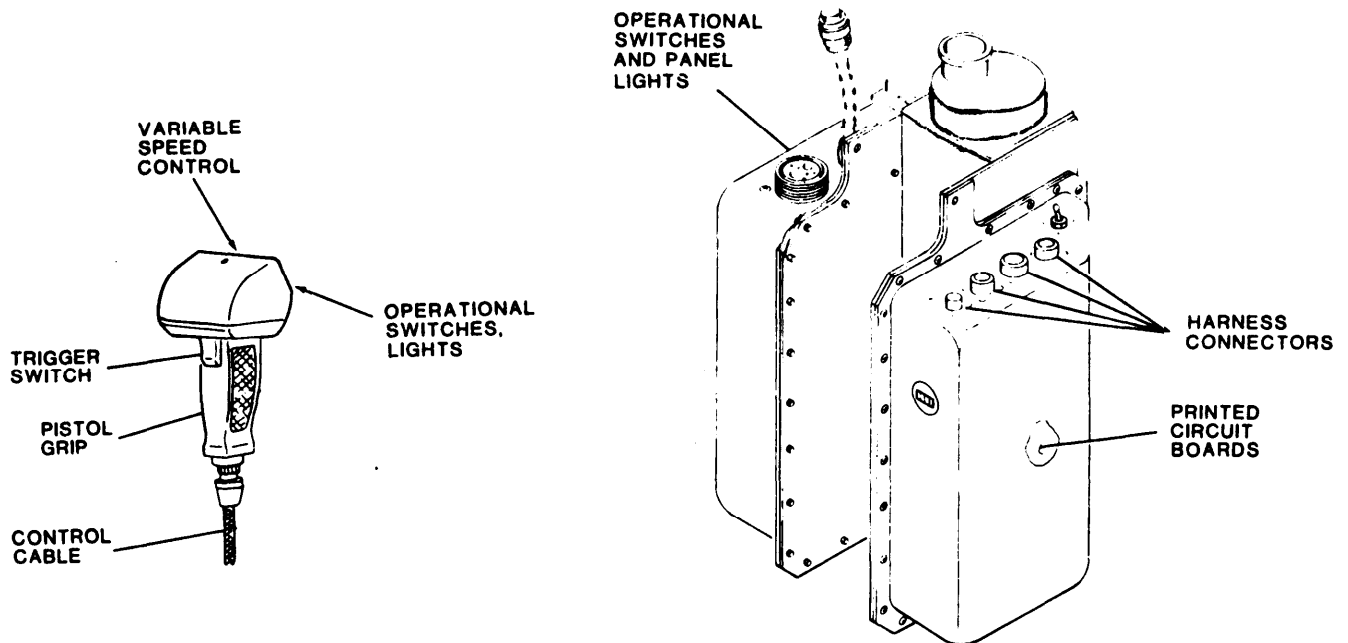


Figure 1-6. Control Panel and Pendant Assemblies

Section IV. SALT WATER OPERATIONS

1-17. General. This section contains the cleaning procedures for the rescue hoist.

a. Preparation for Cleaning. Before cleaning the rescue hoist assembly, cover the control panel assembly and electrical connectors.

b. Cable Assembly.

WARNING

To prevent injury, wear leather gloves when handling cable assembly.

(1) Reel the cable assembly off the storage drum into a large container filled with fresh water and allow to soak for two hours.

CAUTION

Ensure electrical connectors and control panel are covered to prevent salt water from intruding.

(2) Spray storage drum and winch assembly housing interior with fresh water.

WARNING

Lubricating oil is toxic to the skin, eyes and respirator tract. Avoid skin and eye contact. Good general ventilation is normally adequate.

- (3) Allow water to drain from the storage drum assembly and winch housing. Relubricate level wind screw and level wind gears with grease MIL-G-238278 and ball spline assembly with light oil, MIL-L-7808 or MIL-L-23699.
- (4) Using MIL-L-7808 or MIL-L-2369 lubrication oil, re-lubricate the cable assembly while reeling onto the storage drum to aid in replacement of the self-lubricating properties of the cable assembly.

c. Cleaning Electrical Components.

WARNING

Trichloroethane is toxic to eyes, skin and respirator tract. Skin and eye protection required. Avoid repeated or prolonged contact. Good general ventilation is normally adequate.

CAUTION

Do not immerse electrical components in cleaning solvent. Wipe clean cloth dampened in soap and water solution.

- (1) Clean rescue hoist assembly wiring harness with low lint cloth, MIL-C-85403, Type II moistened with trichloroethane, MIL-T-81533.
- (2) Clean control panel assy with low lint cloth, MIL-C-85403, Type II moistened with trichloroethane, MIL-T-81533.
- (3) Clean electrical contact pins with cloth soaked, trichloroethane.

CHAPTER II

AVIATION UNIT MAINTENANCE (AVUM)
MAINTENANCE INSTRUCTIONS**Section I. REPAIR PARTS, SPECIAL TOOLS; TEST, MEASUREMENT,
AND DIAGNOSTIC EQUIPMENT (TMDE); AND SUPPORT EQUIPMENT**

- 2-1. Common Tools and Equipment.** For authorized common tools and equipment, refer to the Modified Table of Organization and Equipment (MTOE) applicable to your unit.
- 2-2. Special Tools, TMDE, and Support Equipment.** Refer to Repair Parts and Special Tools List, Appendix C, for special tools and support equipment. Refer to Test Equipment List, Appendix G, for TMDE.
- 2-3. Repair Parts.** Repair parts are listed and illustrated in Appendix C of this manual.

Section II. SERVICE UPON RECEIPT

2-4. SERVICE UPON RECEIPT OF MATERIAL

This task covers: Unpacking and checking unpacked equipment

INITIAL SETUP

Personnel Required:

67N, UH1 Helicopter Repairer (2)
 67T, UH60 Helicopter Repairer (2)
 91W, Medevac Medics

Equipment Condition:

Hoist in shipping container

Parts/Materials:

None

Equipment Condition Para:

None

Tools and Test Equipment:

Tool Set, NSN 4920-00-567-0476
 Assembly Stand, 42277-808 or
 equivalent
 Shipping Container, 42305R11

References:

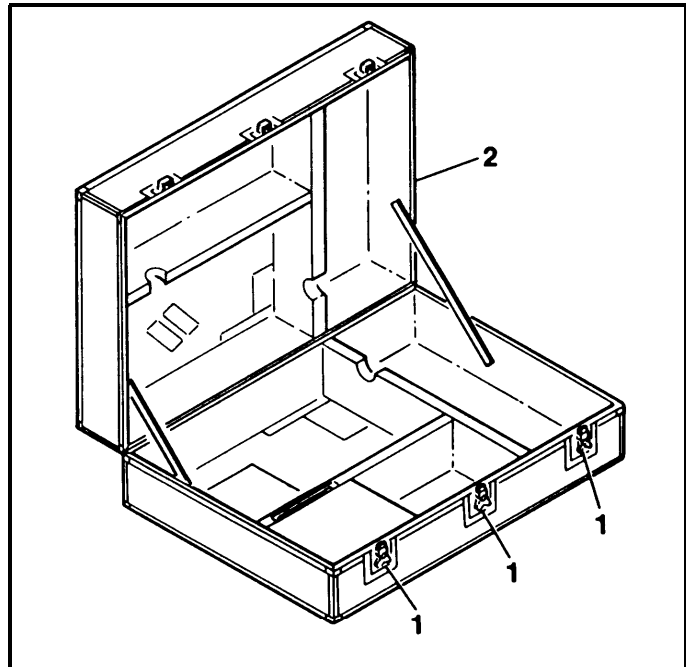
None

1. **Unpacking.**

NOTE

Place rescue hoist reusable shipping container, Part Number 42305R11 on a flat surface. Allow adequate work space for removal of rescue hoist.

- a. Lift three overcenter latch handles (1) and unlatch to release top of shipping container (2).
- b. Grasp top of shipping container (2) and lift up to open.
- c. Release internal retaining strap to remove hoist cable hook.



GO TO NEXT PAGE

2-4. SERVICE UPON RECEIPT OF MATERIAL (cont)

2-4

- d. With a helper, lift hoist from shipping container.
- e. Place rescue hoist on a suitable work surface (or in hoist assembly stand, Part Number 42277-808 or equivalent, in accordance with Task 2-5) for inspection.

2. Checking Unpacked Equipment.

- a. Inspect the hoist for damage incurred during shipment. If the equipment has been damaged, report the damage on DD Form 6, Packaging Improvement Report.
- b. Check the hoist against packing slip to see if shipment is complete. Report all discrepancies in accordance with instructions of DA PAM 738-751.
- c. Check all tags and forms accompanying the hoist to determine the reason for removal from service.
- d. Do not remove any forms or tags that are attached to the hoist until unit is installed and ready for operation. When installed, remove forms and tags and forward to Quality Control (QC) section office.

FOLLOW-ON MAINTENANCE:

None

END OF TASK

This task covers: Installation Instructions for Helicopter and Assembly Stand

INITIAL SETUP

Personnel Required:

67N, UH1 Helicopter Repairer (2)
67T, UH60 Helicopter Repairer (2)
91W, Medevac Medics

Equipment Condition:

Hoist unpacked from shipping container

Parts/Material*

None

Equipment Condition Para:

Task 2-4

Tools and Test Equipment:

Tool Set, Aviation Unit Maintenance
NSN 4920-00-567-0476
Assembly Stand, 42277-808 or equivalent

References:

UH1 Series Helicopter
Maintenance Manual
TM 55-1520-210-23-2
UH60 Series Helicopter
Maintenance Manual
TM 55-1520-237-23-4

WARNING

Ensure external electrical power is removed from system prior to installing rescue hoist. Activated electricity could cause injury to personnel or damage to equipment.

WARNING

Enlist the help of an aide during installation to prevent injury or component damage.

1. **Helicopter Installation.** Install rescue hoist to helicopter in accordance with appropriate UH1 or UH60 series helicopter maintenance manual.

GO TO NEXT PAGE

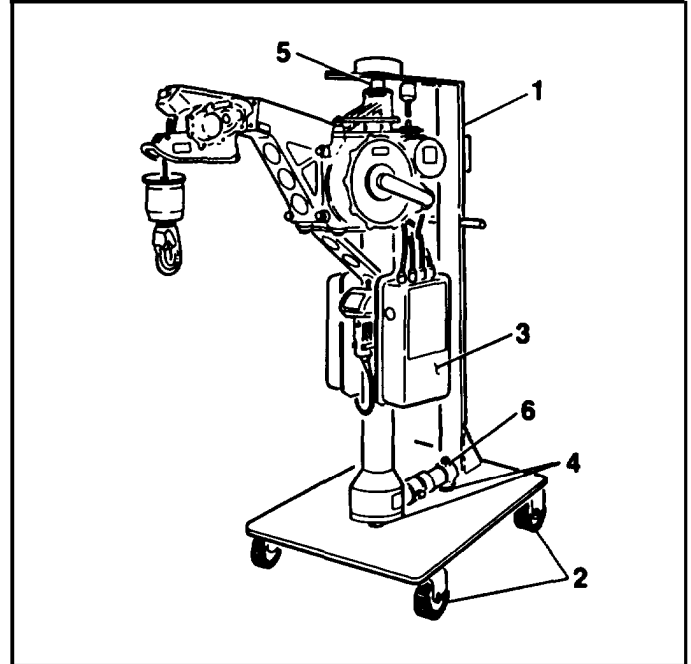
2. Assembly Stand Installation.

- a. Place assembly stand (1), Part Number 42277-808 or equivalent, on a flat surface. Block casters (2) to prevent stand movement during hoist installation.

WARNING

Enlist the help of an assistant when installing hoist to prevent injury to personnel or damage to hoist components. Hoist is heavy and awkward.

- b. Position hoist (3) into assembly stand (1), ensuring alignment of quick disconnect adapters (4) to stand reception holes.
- c. Adjust height adjuster (5) and reaction arm (6) as required to secure hoist (3).

**FOLLOW-ON MAINTENANCE:**

None

END OF TASK

2-6. PRELIMINARY SERVICING OF EQUIPMENT

2-6

This task covers: Preliminary Servicing and Adjustment of Equipment

INITIAL SETUP**Personnel Required:**

67N, UH1 Helicopter Repairer (2)
67T, UH60 Helicopter Repairer (2)
91W, Medevac Medics

Equipment Condition:

Hoist installed in helicopter

Parts/Materials:

None

Equipment Condition Para:

Task 2-5

Tools and Test Equipment:

None

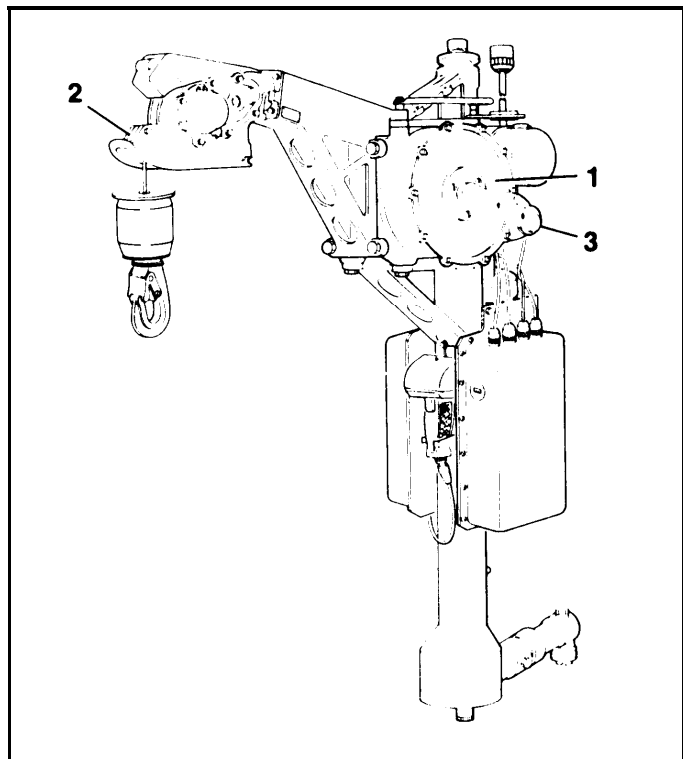
References:

None

WARNING

The hoist cable cutter contains an explosive cartridge. Use extreme caution when handling to prevent injury to personnel. Spark or static producing clothing is prohibited.

- a. Check rescue hoist lubricating oil levels by looking at level sight gauge located on winch assembly (1). Service hoist in accordance with lubrication instruction plates located on the boom head (2) and winch (3) assemblies.
- b. Inspect electrical cables and connectors to ensure proper electrical interconnection. Check for damage and repair as required prior to performing any operational procedures.
- c. Ensure electrical cable harnesses are properly routed free of obstruction and clear of moving parts. Ensure harnesses are properly and securely fastened to hoist.



GO TO NEXT PAGE

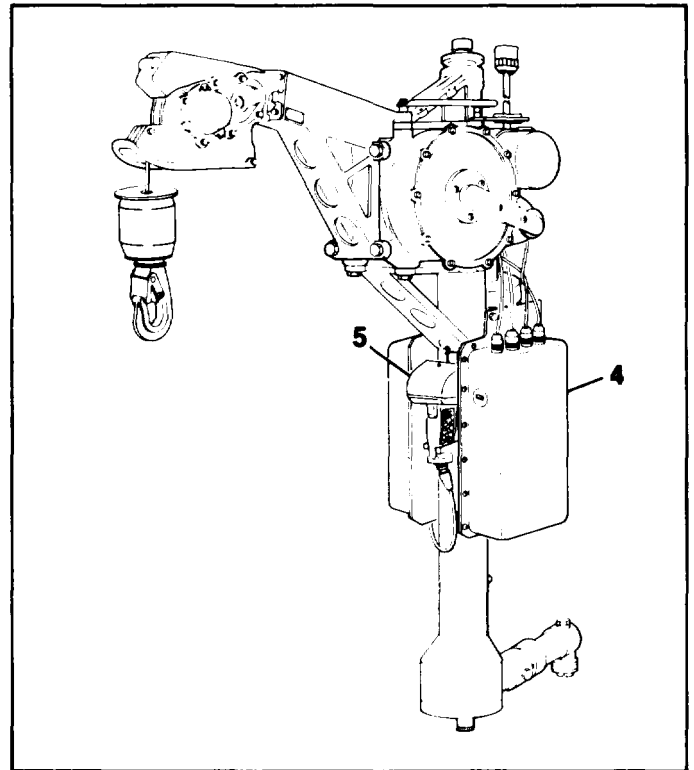
2-6. PRELIMINARY SERVICING AND ADJUSTMENT OF EQUIPMENT (cont)

2-6

- d. Check control panel (4) and control pendant (5) to ensure all operational switches are in the OFF or neutral position prior to activating input power.
- e. Ensure hoist is securely installed and components properly adjusted.

FOLLOW-ON MAINTENANCE:

None

**END OF TASK**

2-7. OPERATIONAL PERFORMANCE CHECK

2-7

This task covers: Conducting After Maintenance and Daily Performance Checks on the hoist

INITIAL SETUP**Personnel Required:**

67N, UH1 Helicopter Repairer (2)
67T, UH60 Helicopter Repairer (2)
91W, Medevac Medics

Equipment Condition:

Hoist installed in helicopter

Parts/Materials:

None

Equipment Condition Para:

Task 2-5

Tools and Test Equipment:

Ground Power Unit (GPU)
MULTIMETER

References:

None

1. Operational Performance Check.**WARNING**

The hoist cable cutter contains an explosive cartridge. Use extreme caution when handling to prevent injury to personnel. Spark or static producing clothing is prohibited. Anytime cable cutter harness is disconnected, install piece of aluminum foil between cartridge pins and install shipping cap to prevent accidental firing.

CAUTION

During performance checks, continually observe OVER TEMP indicator, to ensure that the light is not lit.

GO TO NEXT PAGE

2-7. OPERATIONAL PERFORMANCE CHECK (cont)**2-7**

- a. Connect power source to helicopter. Close rescue hoist CONT and POWER circuit breakers on pilot overhead console.

NOTE

Blue POWER ON light should be on and blower fan shall be operating.

- b. Using pilot boom control switch, rotate the boom in, then out. Observe the 205 degree swing for proper operation.

NOTE

When rescue hoist is installed on left side of aircraft, pilot boom switch operates in reverse.

- c. Using pilot boom control switch, rotate the boom in, then out. Observe the 205 degree swing for proper operation.

· · · · ·
· **CAUTION** ·
· · · · ·

During the following procedures, reel cable out from the boom head in line with the boom axis. Use care not to pull cable taut against cable guide or roller, as kinking of the cable can result. Avoid damaging cable on rough surfaces, such as the ground. Cable from the hoist should be fed onto an improvised drum of at least 9" diameter.

NOTE

Observe that the amber CAUTION light extinguishes when 10 feet of cable is unreeled. Ensure cable speed decelerates (to approximately 67 feet per minute) when cable is within 10 feet of all out (250 feet).

- d. Position the control panel HIGH/LOW SPEED switch to HIGH.
- e. The operator of the pilot hoist control switch must limit cable travel operation to within the first 10 feet and stop. The hoist control pendant operator will immediately resume operation until cable hook is reeled out.

NOTE

During the cable reeling in procedure, push up on actuator arm to ensure proper operation of the up-limit switch. Hoist shall stop running when arm is raised (up-limit switch activated) and resume operation when arm is released.

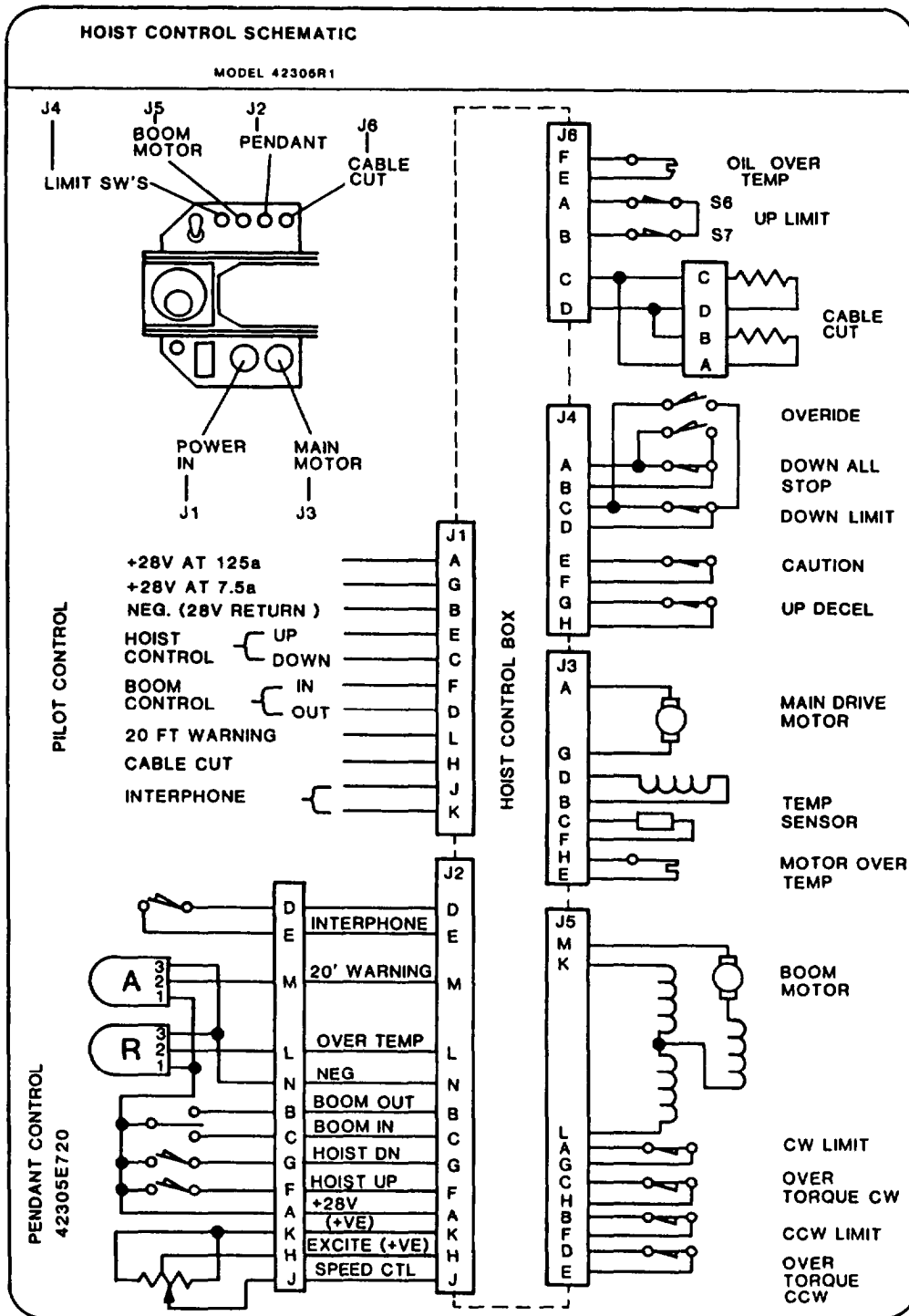
NOTE

Observe that the amber CAUTION light comes on when the cable hook is within 10 feet of the boom head. Ensure cable speed decelerates (to approximately 67 feet per minute). The cable speed shall decelerate to approximately 12 feet per minute when the hook is within 18 inches of the boom head.

- f. The operator of the pilot hoist control switch must limit cable travel operation to within 10 feet of all out (250 feet) and stop. The hoist control pendant operator will immediately resume operation until the cable hook is reeled in.

GO TO NEXT PAGE

2-7. OPERATIONAL PERFORMANCE CHECK (cont)



GO TO NEXT PAGE

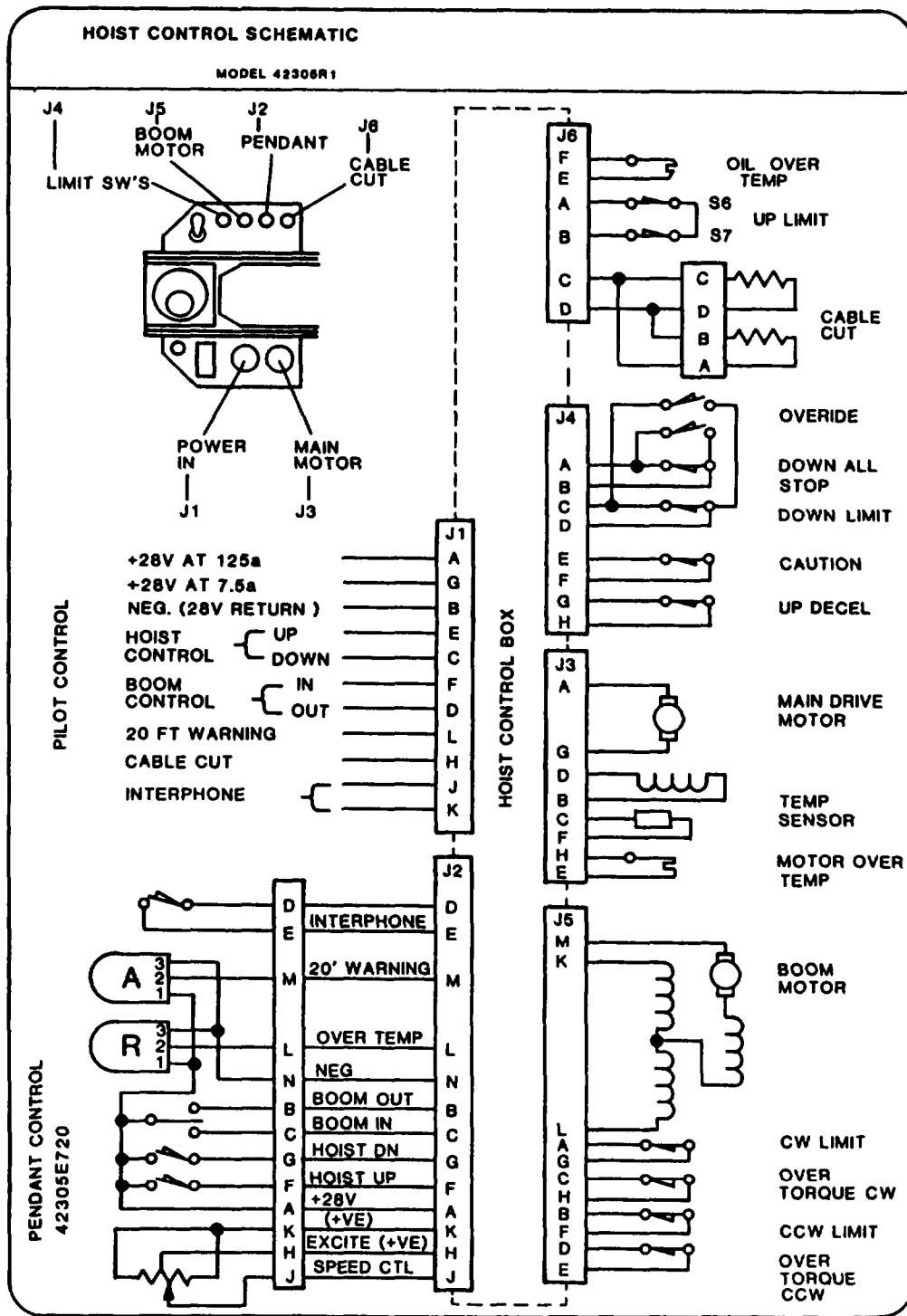
2-7. OPERATIONAL PERFORMANCE CHECK (cont)

2-7

- g. Repeat steps b through f using the control pendant CABLE UP/DOWN switch. Using the pendant speed control lever, ensure cable speed can be varied during the reeling out operation (from 0-250 feet per minute).
 - h. Place control panel HIGH/LOW SPEED switch to LOW and repeat steps b through g.
 - i. Upon completion of tests, reel cable all the way in. Using control pendant BOOM IN/OUT switch, rotate the swinging boom in to stowed position.
 - j. Open rescue hoist CONT and POWER circuit breakers on pilot overhead console. Disconnect power source from helicopter.
2. Systems Teat.
- a. Cable Cutter.
 - (1) Connect a 28 volt dc light to cable cutter connector at boom head.
 - (2) Operate CABLE CUT switch at operators and pilots positions and verify that the light comes on.
 - b. Cooling Fan.
 - (1) Apply 28 vdc across pins A and B of connector J1.
 - (2) Audibly check cooling fan motor for operation. The fan shall produce a high-pitched whine.
 - c. Boom Over-Torque Limit Switches.
 - (1) Check for continuity between pins C and D of connector J5 for the counterclockwise limit switch.
 - (2) Check for continuity between pins D and E of connector J5 for the clockwise limit switch.
 - d. Boom Motor Assembly.
 - (1) Ensure reaction plate and aircraft position switch are positioned properly.
 - (2) Check for continuity between pins K and M of connector J5.
 - (3) Check for continuity between pins L and M of connector J5.
 - e. Lower Limit Switch (205 Degree Rotation).
 - (1) Rotate boom to clockwise position. Check for continuity between pins A and G of connector J5 for the counterclockwise limit switch.
 - (2) Rotate boom to counterclockwise position. Check for continuity between pins B and F of connector J5 for the clockwise limit switch.

GO TO NEXT PAGE

2-7. OPERATIONAL PERFORMANCE CHECK (cont)



GO TO NEXT PAGE

2-7. OPERATIONAL PERFORMANCE CHECK (cont)

2-7

f. Winch Temperature Sensor.

- (1) Disconnect connector J6 from control panel.
- (2) Check for continuity between pins E and F of connector J6

g. Control Pendant BOOM IN/OUT Switch.

- (1) Disconnect connector from control pendant.
- (2) Position the BOOM IN/OUT switch to OUT and check for continuity between pins **A and B** of pendant connector.
- (3) Position the BOOM IN/OUT switch to IN and check for continuity between pins A and C of pendant connector.

h. Up Limit Switch.

- (1) Disconnect connector J6 from control panel. Ensure hook is not against boom head actuator.
- (2) Check for continuity between pins A and B of connector J6,

i. Hoist Input Power.

- (1) Disconnect connector J1 from control panel.
- (2) Check for 28 vdc between pins A, C and J and B(-) of connector J1.
- (3) Check for 28 vdc between pins G, C and S and B(-) of connector J1.

j. Control Pendant CABLE UP/DOWN Switch

- (1) Disconnect connector from control pendant.
- (2) Position the CABLE UP/DOWN switch to DOWN and check for continuity between pins A and G of pendant connector.
- (3) Position the CABLE UP/DOWN switch to UP and check for continuity between pins |A and F of pendant connector.

FOLLOW-ON MAINTENANCE:

None

END OF TASK

Section III. PREVENTIVE MAINTENANCE CHECKS AND SERVICES (PMCS)

2-8. Introduction. This section lists and authorizes preventative maintenance checks and services (PMCS) required for the rescue hoist. The content of the PMCS tables is based upon the principles of reliability centered maintenance (RCM).

2-9. Explanation of Columns.

a. ITEM NO. Column. The number used to identify sequence of checks and services. This column shall be used as a source of item numbers for the TM Number Column on DA Form 2404, Equipment Inspection and Maintenance Worksheet, when recording results of PMCS.

b. INTERVAL Column. Indicates the time interval upon which the checks and services must be performed. Intervals are divided as follows:

- D Daily
- w Weekly
- M Monthly
- A Annually

c. ITEM TO BE INSPECTED Column. Indicates item and components to be inspected.

d. PROCEDURES Column. Indicates the procedure by which the check or service is to be performed. Tolerances, adjustment limits, and instrument readings are included as applicable. When replacement or repair of a component is required, the procedures column will direct personnel to the appropriate task.

TABLE 2-1. ORGANIZATIONAL PREVENTIVE MAINTENANCE CHECKS AND SERVICES

ITEM NO.	INTERVAL				ITEM TO BE INSPECTED	PROCEDURES
	D	W	M	A		
1				*	Boom Head (Service)	Drain and service boom head assembly by removing drain plugs and servicing plugs from sidecover. Reinstall drain plugs and service in accordance with instructions on lubrication plate. Install servicing plug. Service boom head assembly in accordance with Task 2-18.
2	*				Boom Head Assembly	Visually inspect for cracks, leaks, dents, corrosion. Check for freedom of movement by rotating boom head assembly against the stops. Inspect identification and lubrication plates for legibility and security of attachment. Inspect harness assembly for cuts, tears, fraying and broken insulation. Inspection shall be in accordance with Task 2-17.

Table 2-1. ORGANIZATIONAL PREVENTIVE MAINTENANCE CHECKS AND SERVICES (cont)

ITEM NO.	INTERVAL				ITEM TO BE INSPECTED	PROCEDURES
	D	W	M	A		
3		*			Actuator Assembly	Check adjustment of upper limit actuator assembly by measuring the distance between top of actuator and cable guide. Dimension should be 0.75 inch (1.91 cm). Press up on actuator arm until switches are engaged. Measure the distance between the top of arm and cable guide. Dimension should be 0.44 inch (1.18 cm). Adjust actuator assembly in accordance with Task 2-24.
4		*			Cable Cutter	<p style="text-align: center;">NOTE</p> <p style="text-align: center;">If the cable cutter has been activated, repair the cable cutter in accordance with Task 2-22A.</p> <p>Visually inspect electrical connector for bent, broken and missing pins. Inspect cable for frayed and broken insulation. Check for cuts and tears. Check expiration data of cartridge.</p>
5		*			Winch Assembly	Visually inspect for nicks, cracks corrosion and evidence of leakage. Inspect identification and lubrication plates for legibility and security of attachment. Inspect electrical wiring for frayed or broken insulation. Inspect electrical connector for bent, broken or missing pins. Inspect mounting hardware for security. Inspection shall be in accordance with Task 2-44.
6				*	Winch Assembly Service	Drain and service winch assembly by removing drain and breather plugs from winch assembly. Reinstall drain plugs and service in accordance with lubrication instructions. Install breather plug. Service winch assembly in accordance with Task 2-22A.

Table 2-1. ORGANIZATIONAL PREVENTIVE MAINTENANCE CHECKS AND SERVICES (cont)

ITEM NO.	INTERVAL				ITEM TO BE INSPECTED	PROCEDURES
	D	W	M	A		
7	*				Hook Assembly	<p>Visually inspect for nicks, cuts, dents or corrosion. Inspect keeper for smooth operation, free of binding or sticking. Ensure cable hook is securely attached to hoist cable. Inspection shall be in accordance with Task 2-56.</p>
8	*				Cable Assembly	<p>Clean the length of the cable used during the last operation, using a clean heavy lint free cloth. Hold cloth firmly around cable, which shall aid in the removal of foreign particles and in detection of broken wires. Simultaneously check cable for kinks, bird caging abrasions and flat spots, as follows:</p> <p>Kinks are caused by a loop in the cable being pulled up tight, resulting in a sharp permanent bend.</p> <p>Bird caging is stretching or untwisting of the outer wraps of wire strands.</p> <p>Flat spots on outer wire strands are evidence of cable misrouting or misalignment. Align winch drum in accordance with Task 2-64.</p> <p>Localized worn sections or abrasions on outer wire strands are evidence of an improperly aligned or defective winch drum. Align winch drum in accordance with Task 2-64.</p> <p>Broken wires, strands, bird caging, kinks or flat spots are cause for cable replacement. Replace cable in accordance with Task 2-60.</p> <p>Ten iterations could cause a bird cage effect at the cable ball at the hook. This is caused by the outer cable wrapper traveling over the inner cable downward. If a stretch of 250 feet with training load were done two times, the bird cage effect could possibly be stopped before it happens and thus, save a cable change.</p>

Table 2-1. ORGANIZATIONAL PREVENTIVE MAINTENANCE CHECKS AND SERVICES (cont)

ITEM NO.	INTERVAL				ITEM TO BE INSPECTED	PROCEDURES
	D	W	M	A		
8A		*			Cable Assembly	<p>Clean full length of the cable using a clean heavy lint-free cloth. Hold cloth firmly around cable which shall aid in the removal of foreign particles and in detection of broken wires. Simultaneously check cable for bird caging, kinks, abrasions and flat spots, as follows:</p> <p>Bird caging is stretching or untwisting of the outer wraps of wire strands. During Daily inspection of the cable assembly and performing hoist mission, (continuously using same length of cable) extending and retracting the cable outer strands to loosen, and with held weight of the cable in the stowed position within the storage drum bird cage may form. Prevent bird caging in accordance with Task 2-59.</p> <p>Permit the cable outer strands to loosen, and with the weight of the cable in the stowed position drum bird cage may form. Prevent bird caging in accordance with Task 2-59.</p> <p>Kinks are caused by loop in the cable being pulled uptight, resulting in a sharp permanent bend.</p> <p>Localized worn sections or abrasions on outer wire strands are evidence of an improperly aligned or defective winch drum. Align winch drum in accordance with Task 2-64.</p> <p>Flat spots on outer wire strands are evidence of cable misrouting or misalignment. Align winch drum in accordance with Task 2-64.</p> <p>Broken wires, strands, bird caging, kinks or flat spots are cause for cable replacement. Replace cable in accordance with Task 2-60.</p>

Table 2-1. ORGANIZATIONAL PREVENTIVE MAINTENANCE CHECKS AND SERVICES (cont)

ITEM NO.	INTERVAL				ITEM TO BE INSPECTED	PROCEDURES
	D	W	M	A		
9			*		Motor Assembly	Visually inspect for evidence of over-heating or shorting. Ensure electrical connector is secured. Check electrical wiring for frayed or broken insulation. Check electrical motor installation for security.
9A				*	Motor Assembly	Visually inspect for evidence of over-heating or shorting. Check electrical connector for bent, broken or missing pins and security. Check electrical wiring for frayed or broken insulation. Check electrical motor installation for security. Inspection shall be in accordance with Task 2-49.
10		*			Boot Assembly	Visually inspect for cuts, tears or deterioration. Replace in accordance with Task 2-50.
11	*				Limit Switch Drive Assy	Visually inspect for cracks, nicks, corrosion. Check electrical wiring for frayed or broken insulation. iCheck cams for excessive play. Check sprocket for wear, nicks, burrs and chipped spline teeth. Inspection shall be in accordance with Task 2-53. Check adjustment of switch. Adjust limit switch in accordance with Task 2-54.
12	*				Drum Assy	Refer to the illustration on page 2-127. Remove screws (11) and plate (8). Visually inspect for cracks, dents, nicks. Inspect drum grooves for distortion or abnormalities and uneven wear. Visually inspect cable kicker with a mechanical mirror for cracks, dents or nicks.
13			*		Drum Assy	Check alignment of drum assembly by removing pressure cover item (1) on illustration, page 2-126. While reeling in cable, observe cable travel through cable cutter assembly. Cable should not contact cable cutter. If required, align drum assembly in accordance with Task 2-64.
14	*				Control Panel Assy	Visually inspect for cracks, dents, broken power light and security of switches.

Table 2-1. ORGANIZATIONAL PREVENTIVE MAINTENANCE CHECKS AND SERVICES (cont)

ITEM NO.	INTERVAL				ITEM TO BE INSPECTED	PROCEDURES
	D	W	M	A		
15		*			Control Pendant Assy	Visually inspect for cracks or dents. Pressure to test the serviceability for the temperature and caution light. Check electrical connector for bent, broken or missing pins. Ensure operational switches operate smoothly, free of binding or sticking. Check for stripped, crossed or damaged threads. Inspection shall be in accordance with Task 2-15.
16	*				Control Cable	Visually inspect for cuts, tears, fraying or broken insulation. Check cable connectors for bent, broken or missing pins. Check for crossed, stripped or damaged threads. Inspection shall be in accordance with Task 2-65.
17		*			Cable Umbilical	Visually inspect for cuts, tears, fraying or broken insulation. Check electrical connector for bent, broken or missing pins. Check for evidence of overheating or shorting. Check threaded parts for crossed, stripped or damaged threads. Inspection shall be in accordance with Task 2-65.
18	*				Boom Position Support Assembly	Visually inspect for cracks, loose mounting hardware and corrosion. Check for dents on the stanchion tube, upper and lower support and switch cover. Check aircraft position plate for legibility and security of attachment. Inspect hook and pendant spring for damage. Inspection shall be in accordance with Task 2-28.
19		*			Height Adjuster	Visually inspect for nicks, cracks corrosion. Ensure smooth operation, free of binding or sticking. Check plunger locking device by placing plunger in locked position and attempt to rotate height adjuster.

Table 2-1. ORGANIZATIONAL PREVENTIVE MAINTENANCE CHECKS AND SERVICES (cont)

ITEM NO.	INTERVAL				ITEM TO BE INSPECTED	PROCEDURES
	D	W	M	A		
20	*				Quick Disconnect	Check upper and lower quick disconnectors for corrosion and cracks. Check locking action of jaw when placed in the closed position. Inspection shall be in accordance with Task 2-34, 2-42.
21	*				Reaction Arm	Slide extension arm forward and aft on the arm pivot, binding should not occur. If binding occurs, replace reaction arm in accordance with Task 2-41. Check quick disconnect for smooth operation. Check for cracks, nicks, dents. Check release pin for damage. Inspection shall be in accordance with Task 2-40
					NOTE	
					Inspection interval is weekly if hoist is installed; inspection interval is monthly if hoist is <u>NOT</u> installed.	
22		*	*		Rescue Hoist	Perform operation checks in accordance with step1. of Task 2-7

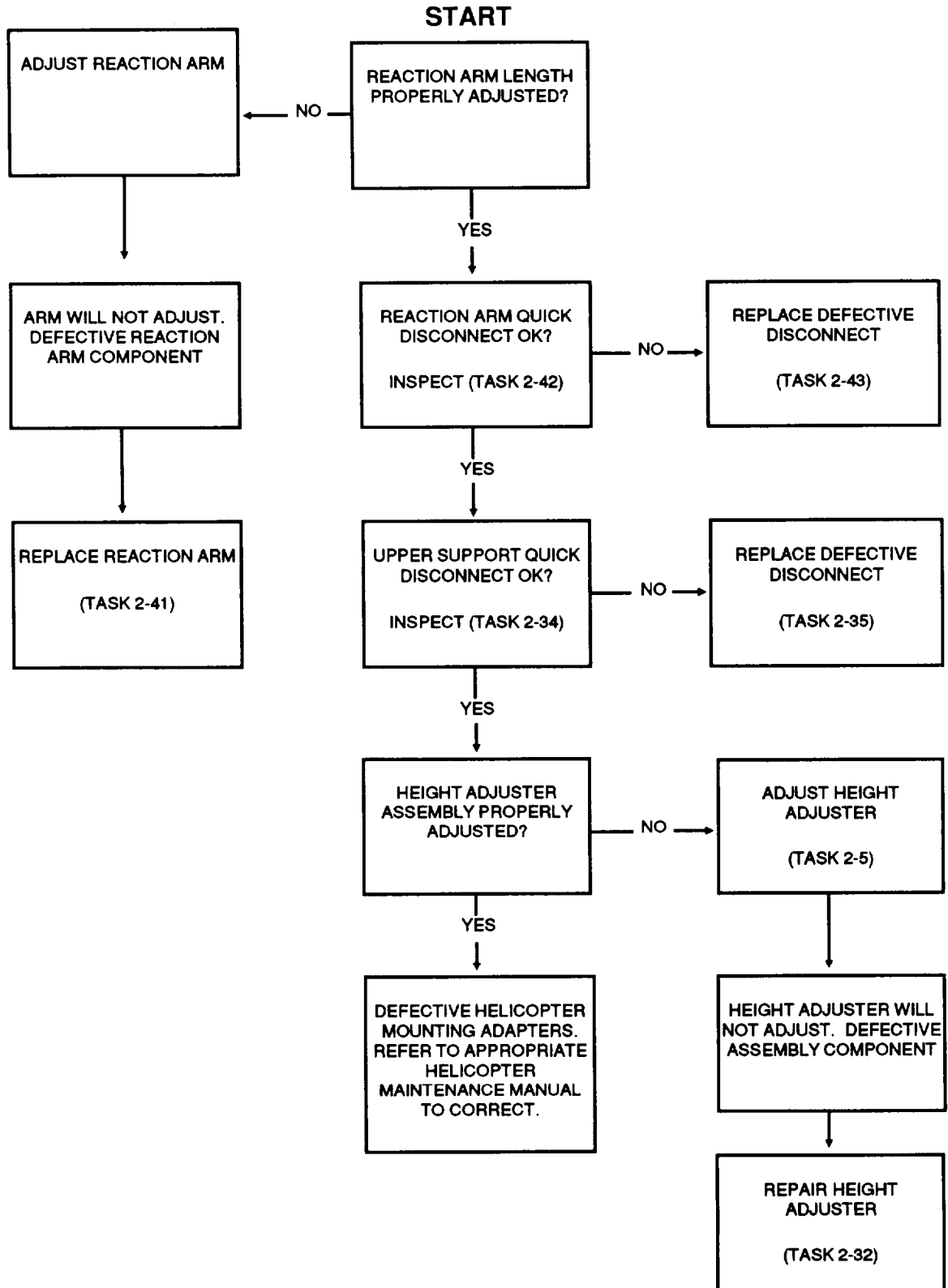
Section IV. TROUBLESHOOTING

2-10. Troubleshooting. If malfunction or failure occurs during operation or performance check, perform troubleshooting in accordance with logic tree diagrams. Refer to table 2-2, Symptom Index, for determining applicable troubleshooting procedure.

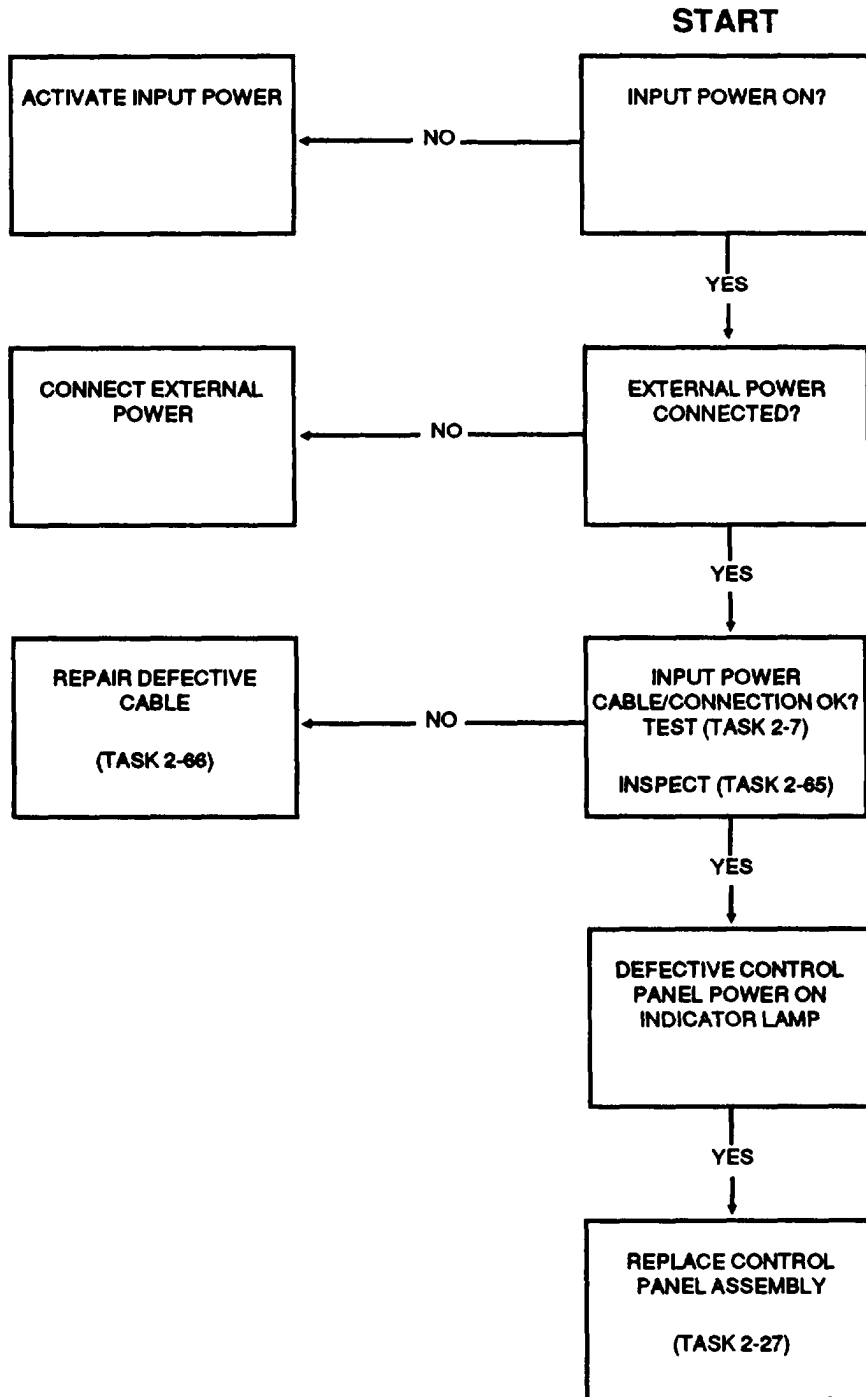
Table 2-2. SYMPTOM INDEX

Symptom	Troubleshooting Procedure
Boom Head Assembly	
Does not swing full 205 degrees	4
Inoperative	3
Overheats	14
Brake	
No positive brake action	11
Positive action deceleration inoperative	6
Control Panel	
Operating switch inoperative	18
Pilots override control inoperative	17
Control Pendant	
Intercom inoperative	16
Operating switch inoperative	18
Hoist Cable	
Does not reel smoothly	
Lamps/Indicators	
Caution lamp inoperative	7
Temp warning lamp inoperative	15
Rescue Hoist	
Hoist does not install properly	1
Inoperative	2
Winch Assembly	
Cable speed-less than 100 RPM	8
Cable speed-exceeds 15 RPM	9
Hoist Cable does not reel smoothly	10
Inoperative	5
Overheats	13
Winch motor overheats	12

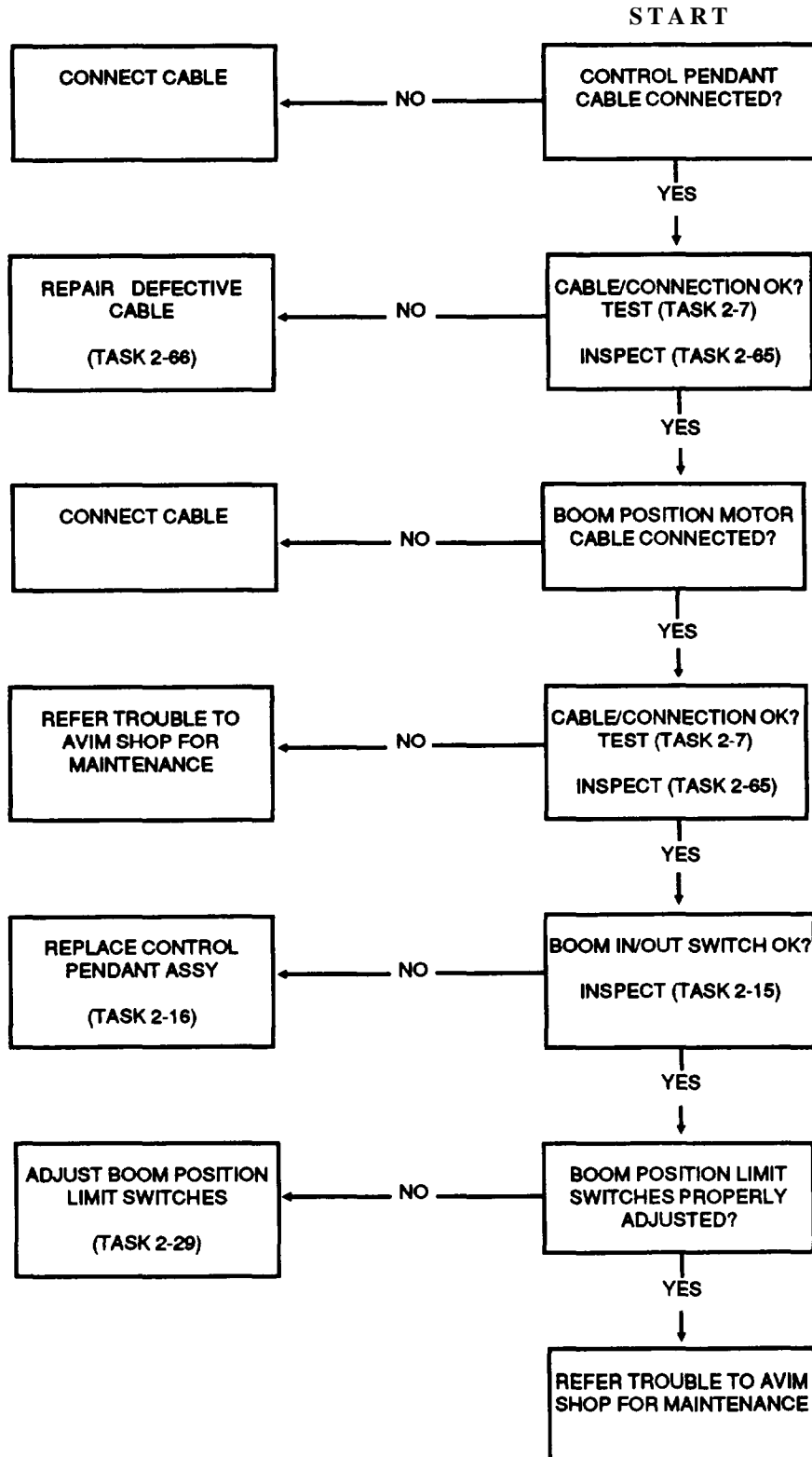
TROUBLESHOOTING PROCEDURE 1. RESCUE HOIST DOES NOT INSTALL PROPERLY



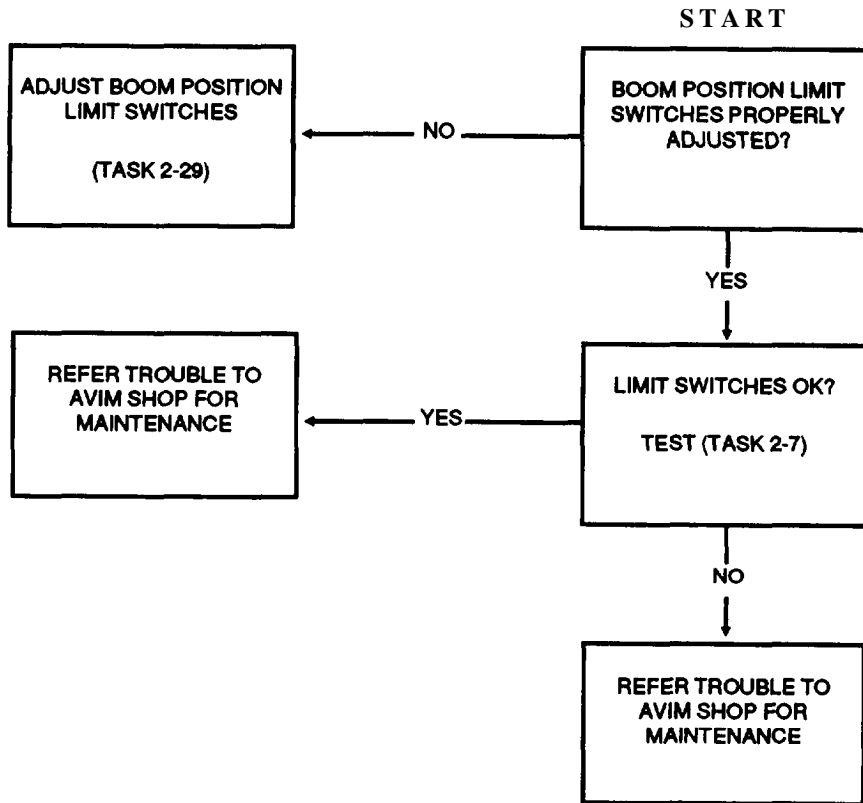
TROUBLESHOOTING PROCEDURE 2. RESCUE HOIST INOPERATIVE, CONTROL PANEL POWER ON INDICATOR DOES



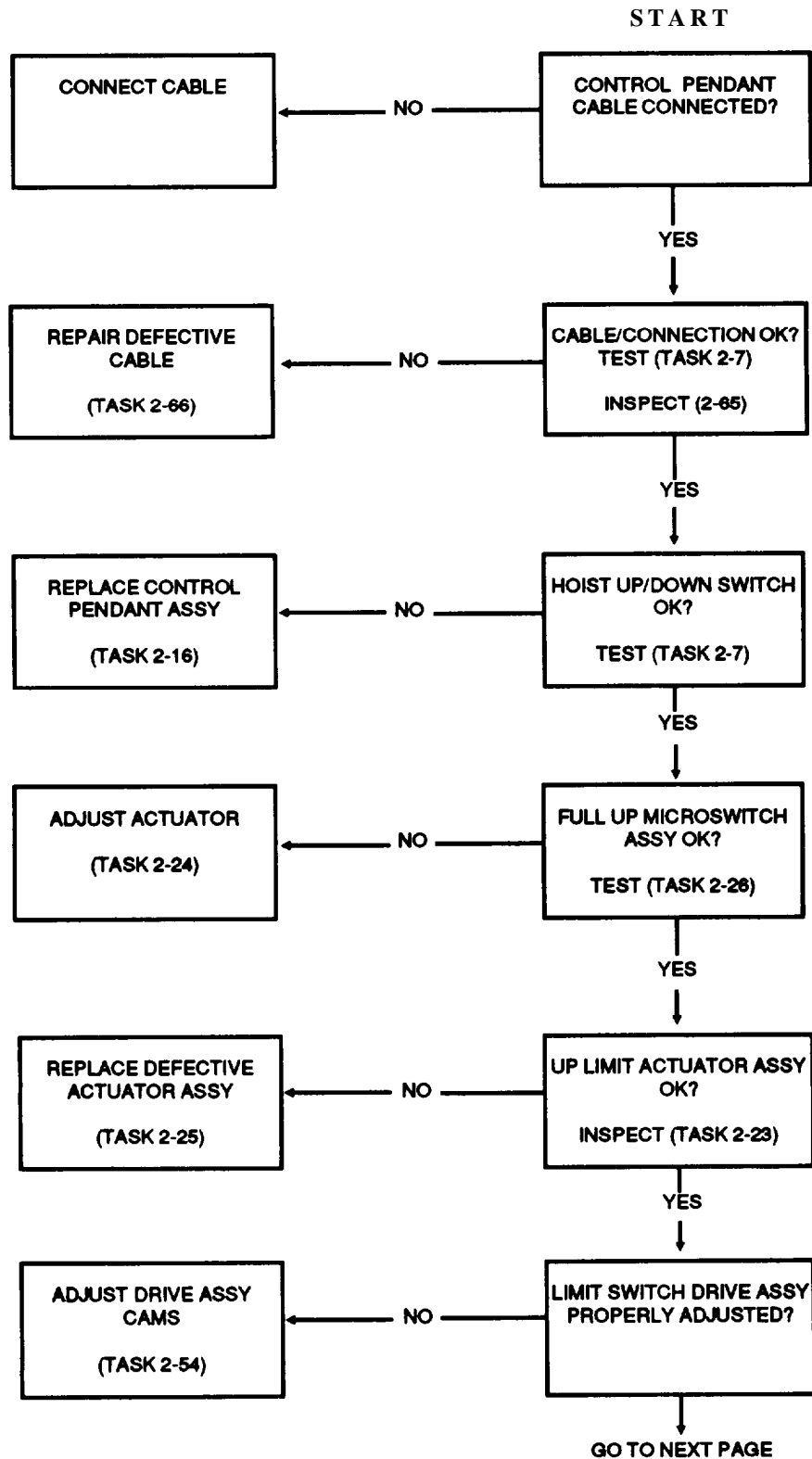
TROUBLESHOOTING PROCEDURE 3. HOIST BOOM INOPERATIVE, BOOM IN/OUT SWITCH ACTIVATED



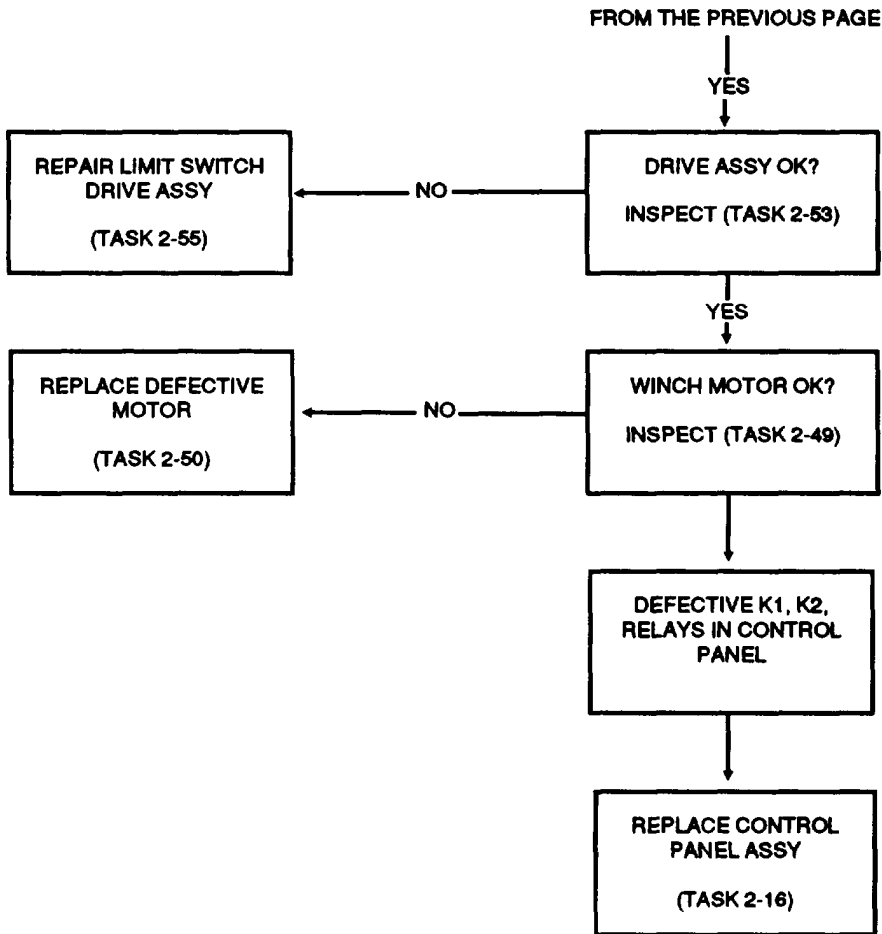
TROUBLESHOOTING PROCEDURE 4. HOIST BOOM DOES NOT SWING FULL
205 DEGREES



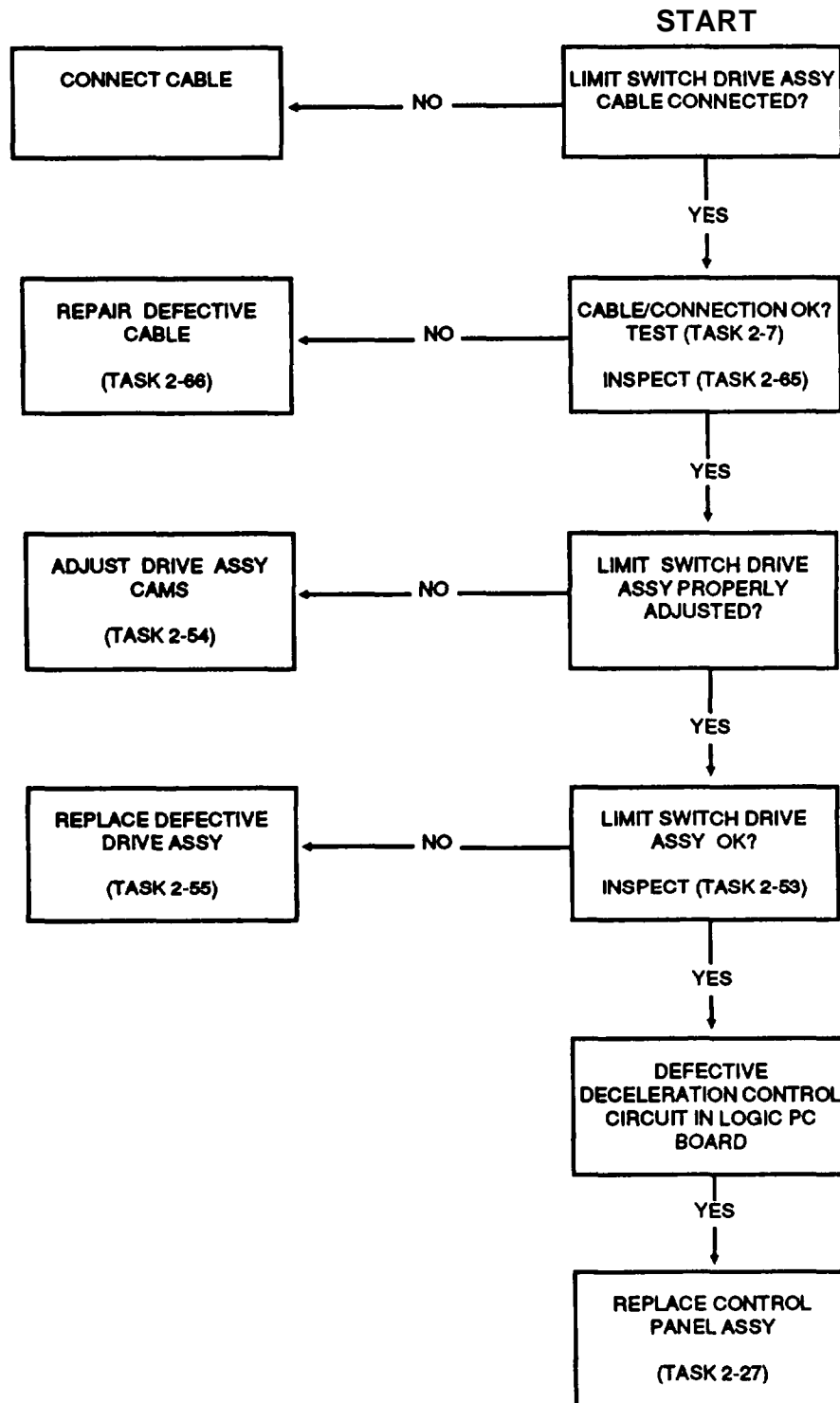
TROUBLESHOOTING PROCEDURE 5. HOIST WINCH INOPERATIVE, HOIST UP/DOWN SWITCH ACTIVATED



TROUBLESHOOTING PROCEDURE 5. (CONT) HOIST WINCH INOPERATIVE,
HOIST UP/DOWN SWITCH
ACTIVATED

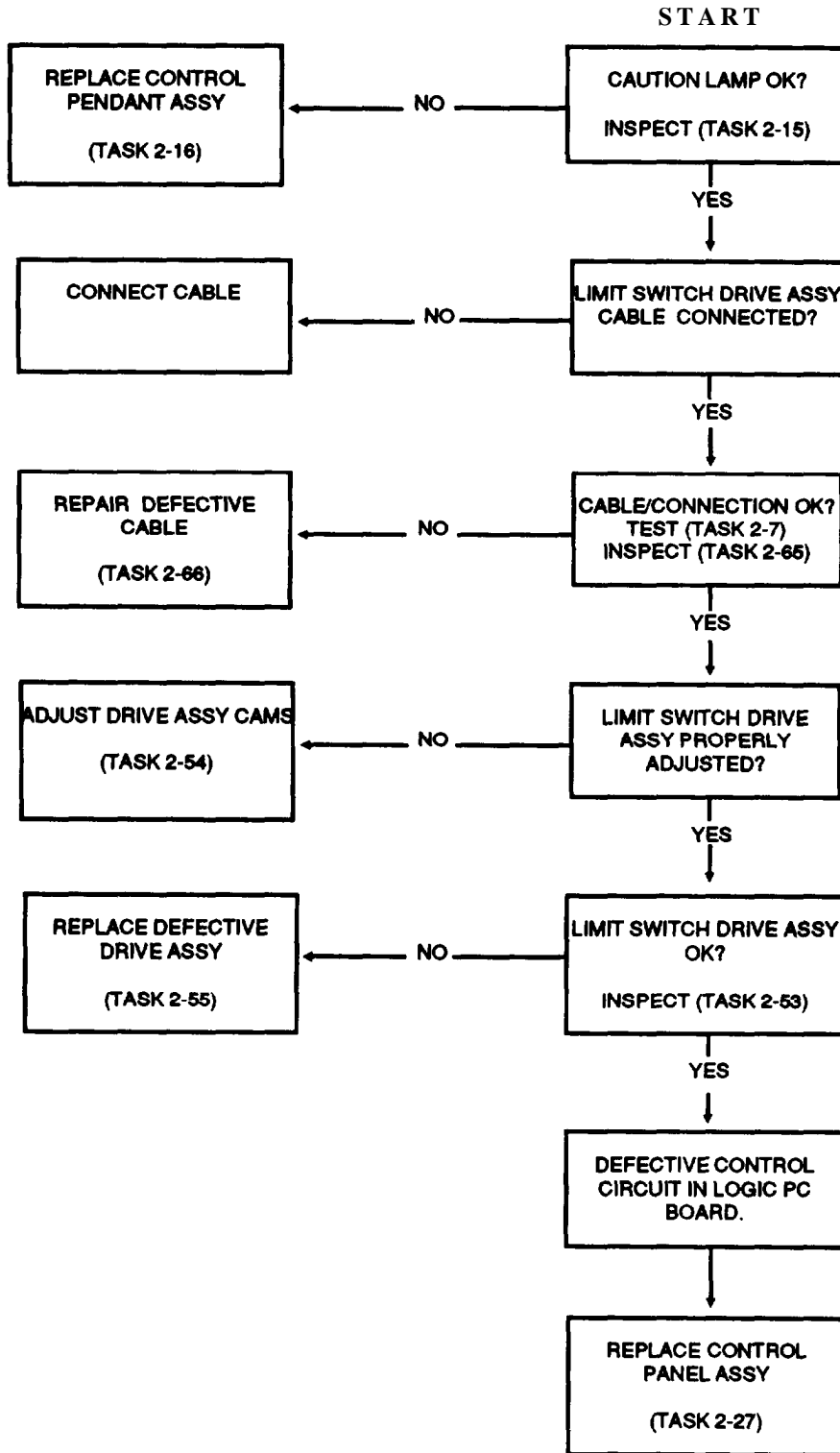


**TROUBLESHOOTING PROCEDURE 6. NO POSITIVE ACTION DECELERATION.
HOOK WITHIN 3 FEET OF DOWN-STOP
LIMIT (EXTENSION) OR 1 FOOT FROM
FULL STOW (REEL IN)**

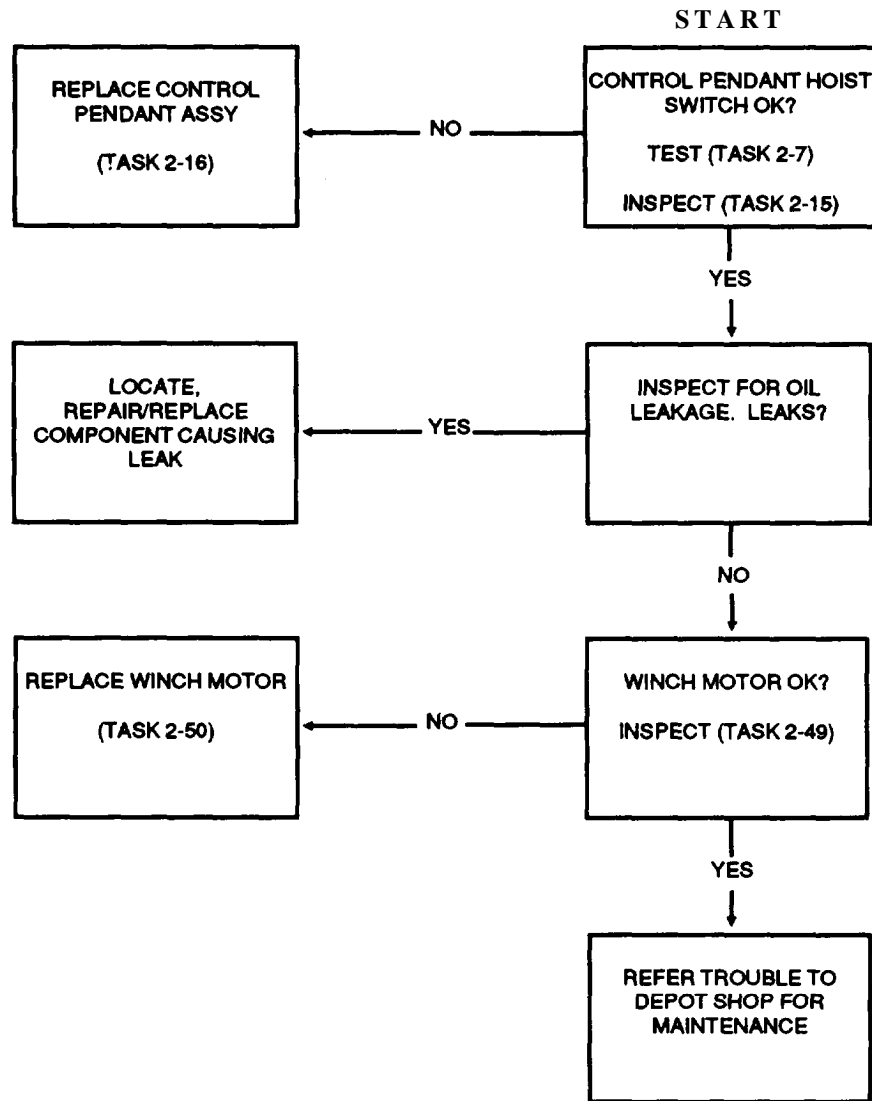


TROUBLESHOOTING

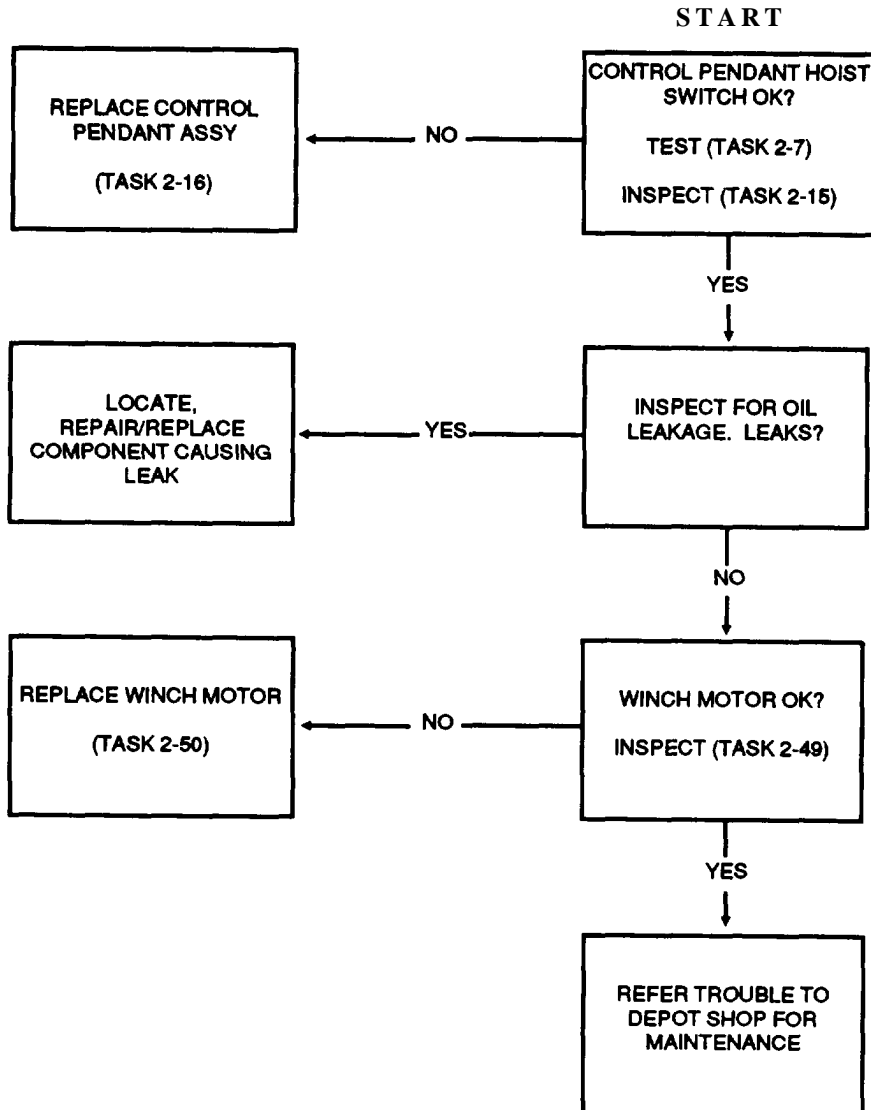
7. CAUTION LAMP DOES NOT ILLUMINATE.
CABLE HOOK WITHIN 8-10 FEET OF
FULL STOW



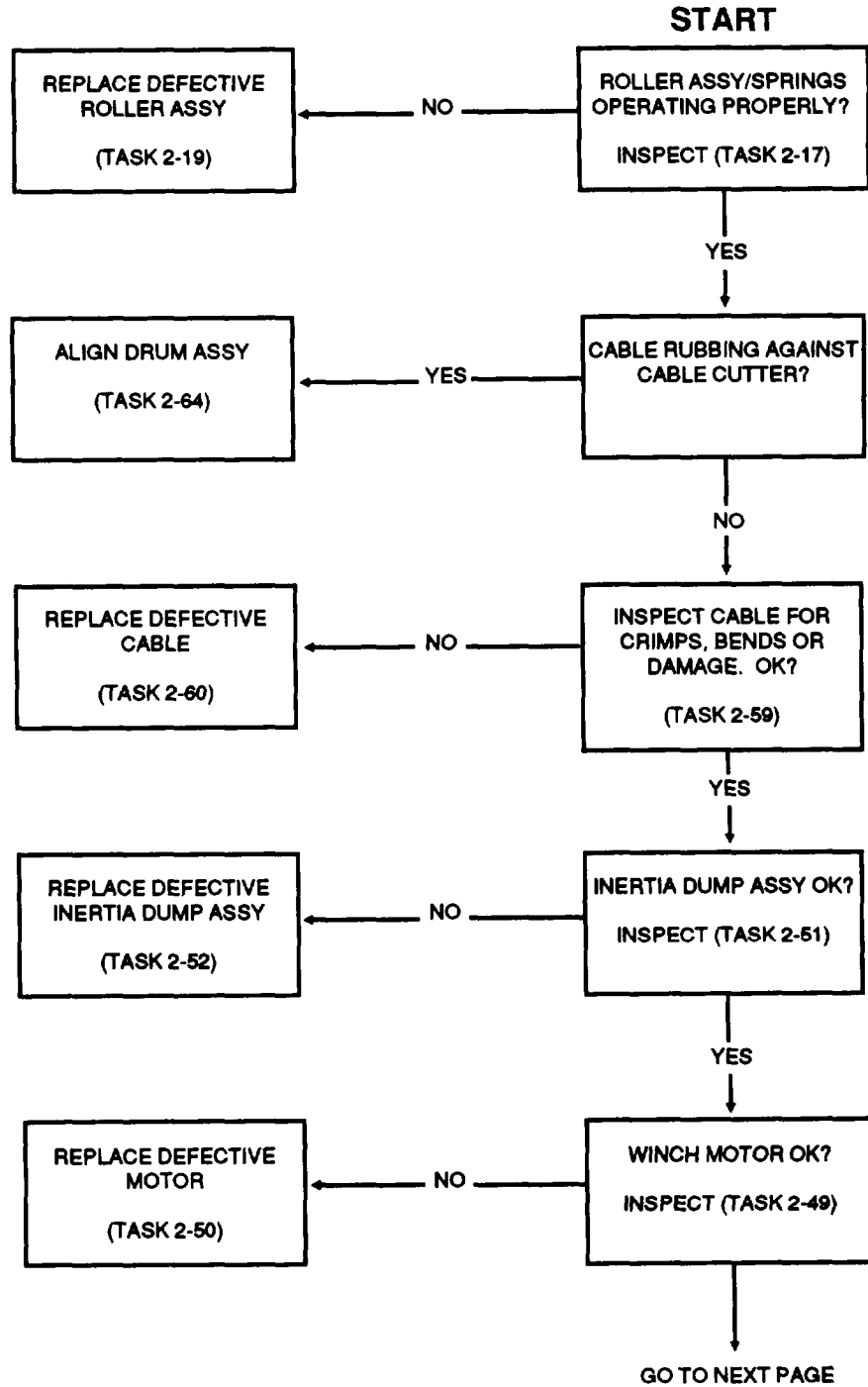
**TROUBLESHOOTING PROCEDURE 8. CABLE SPEED LESS THAN 100 RPM,
HOIST OPERATED AT MAXIMUM**



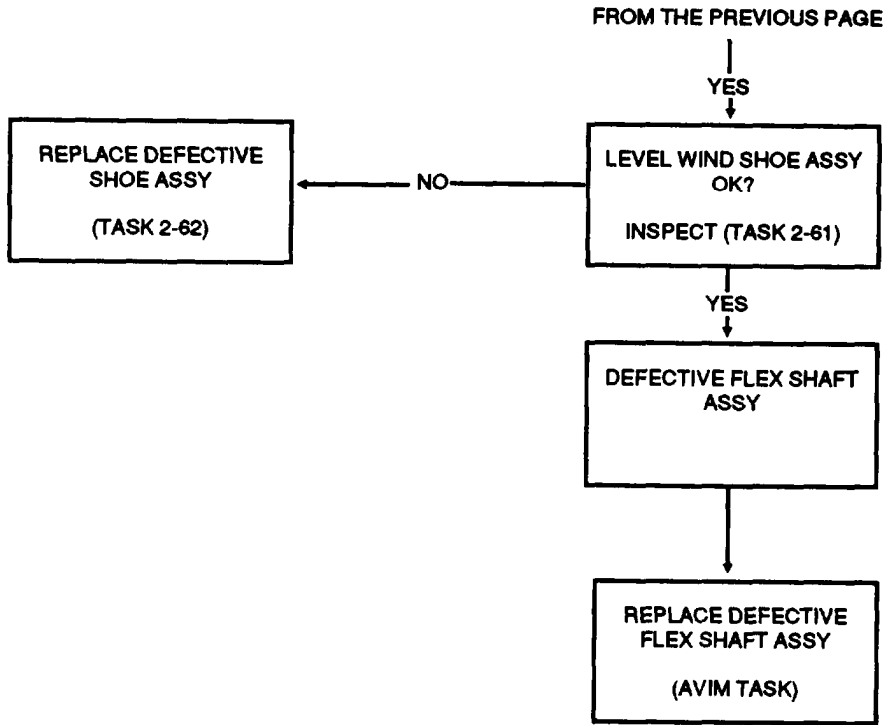
TROUBLESHOOTING PROCEDURE 9. CABLE SPEED EXCEEDS 15 RPM, HOIST OPERATED AT MINIMUM



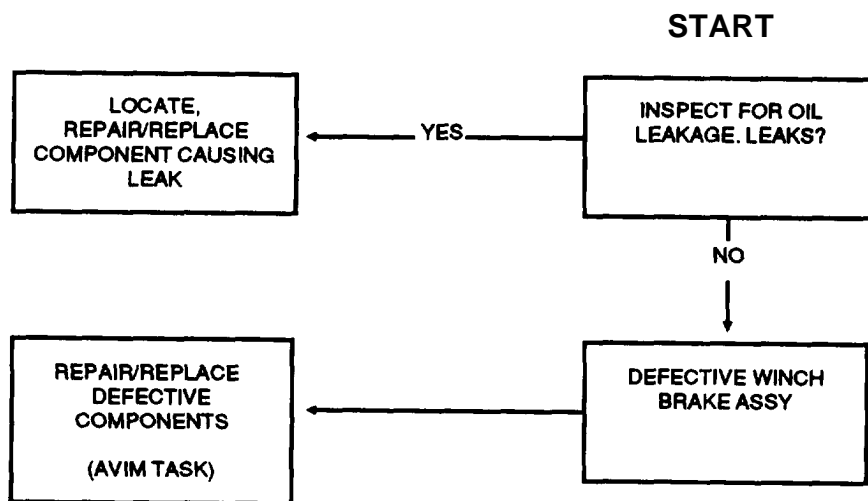
TROUBLESHOOTING PROCEDURE 10. HOIST CABLE DOES NOT REEL SMOOTHLY



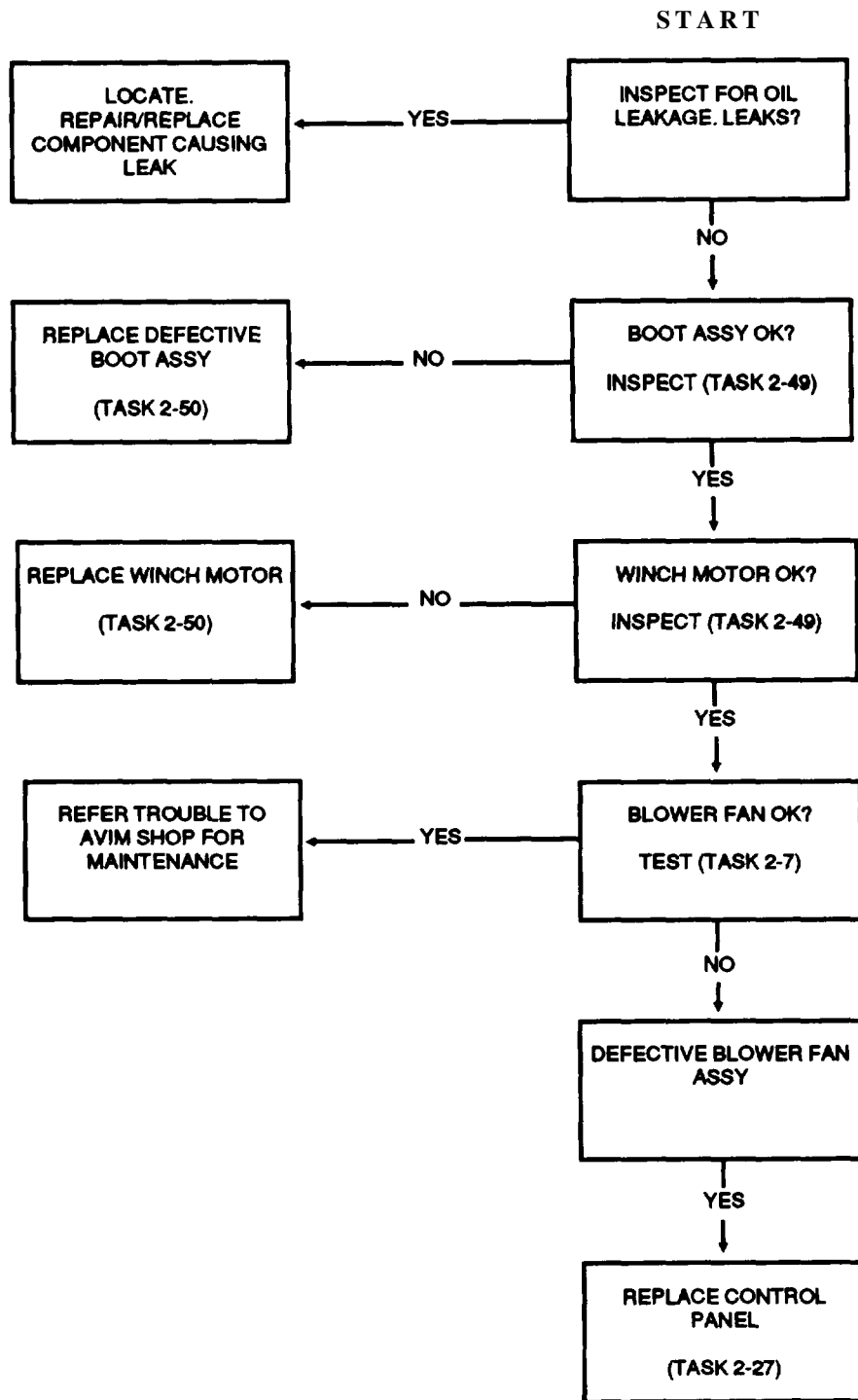
TROUBLESHOOTING PROCEDURE 10. (CONT) HOIST CABLE DOES NOT REEL SMOOTHLY



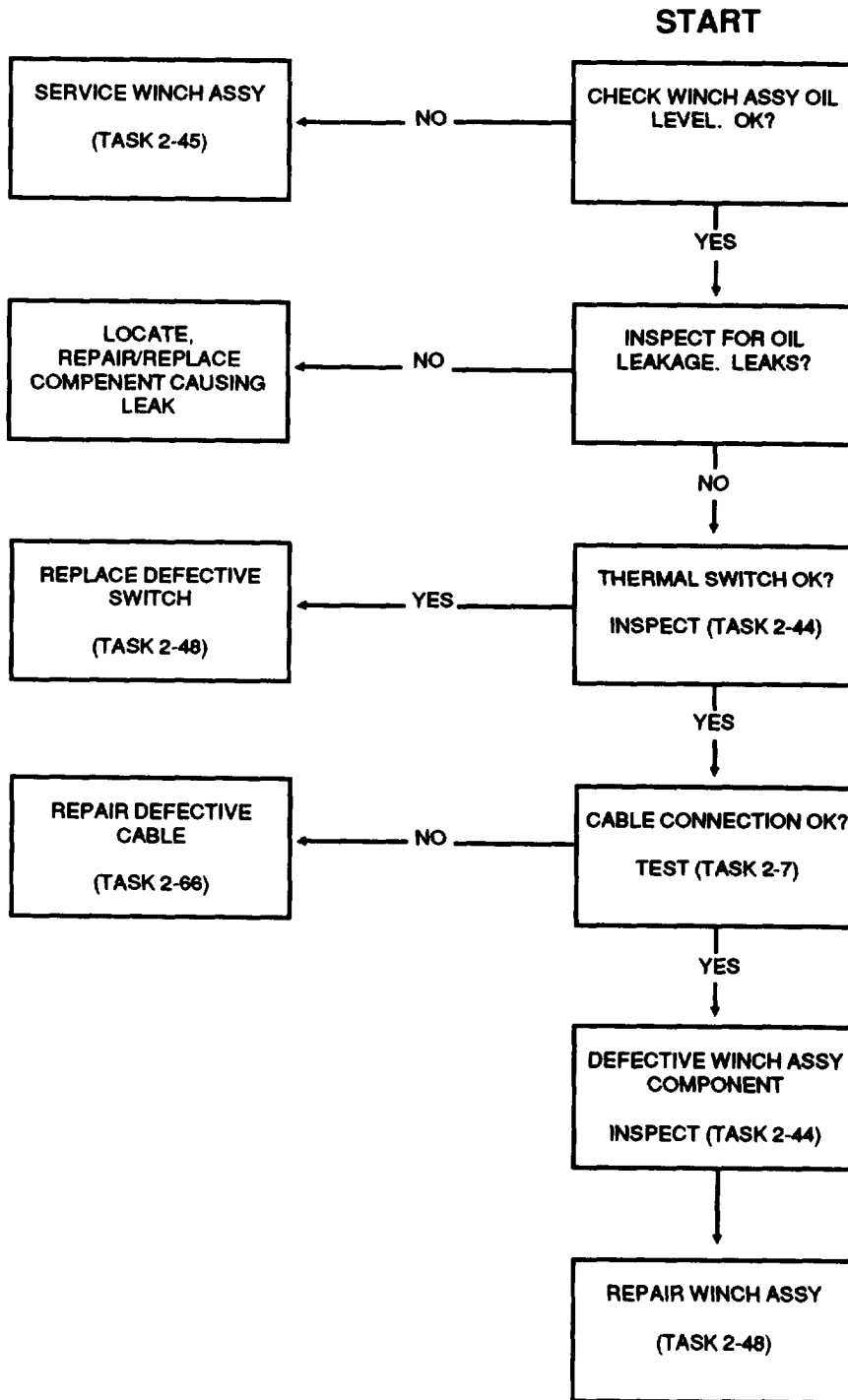
TROUBLESHOOTING PROCEDURE 11. NO POSITIVE BRAKE ACTION



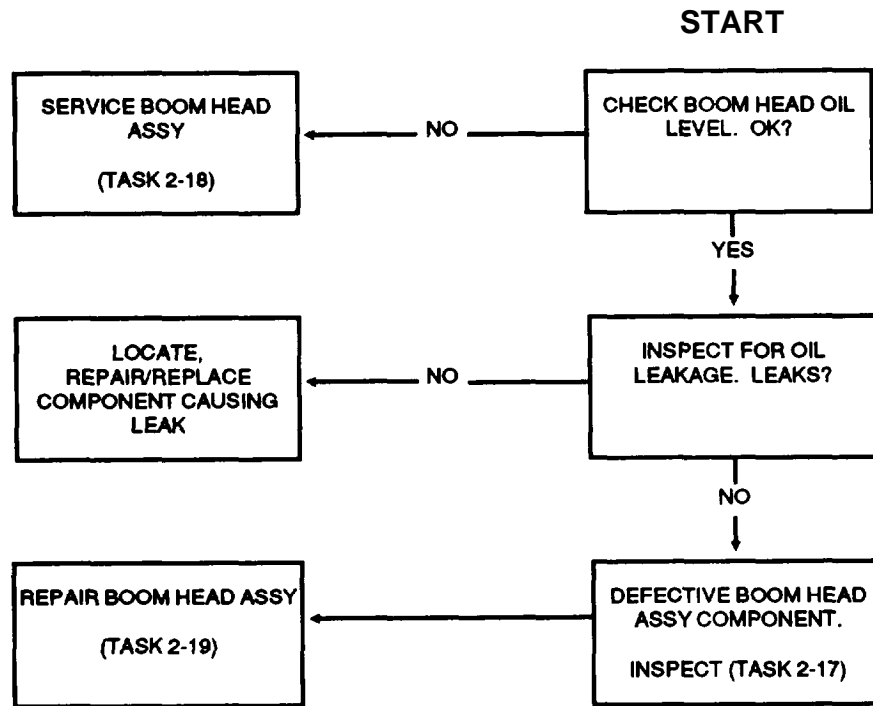
TROUBLESHOOTING PROCEDURE 12. ELECTRIC WINCH MOTOR OVERHEATS



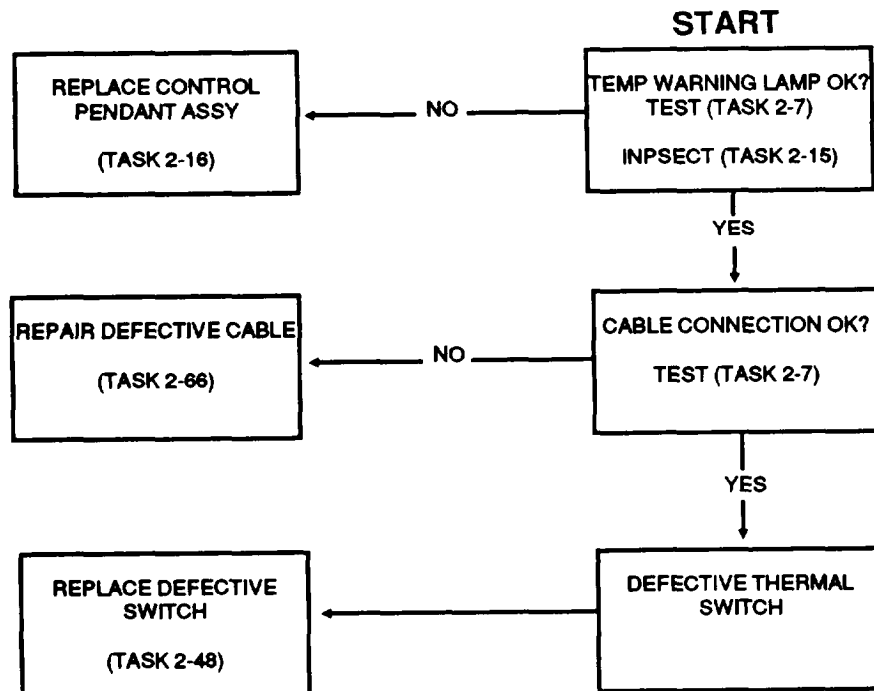
TROUBLESHOOTING PROCEDURE 13. WINCH ASSY OVERHEATS



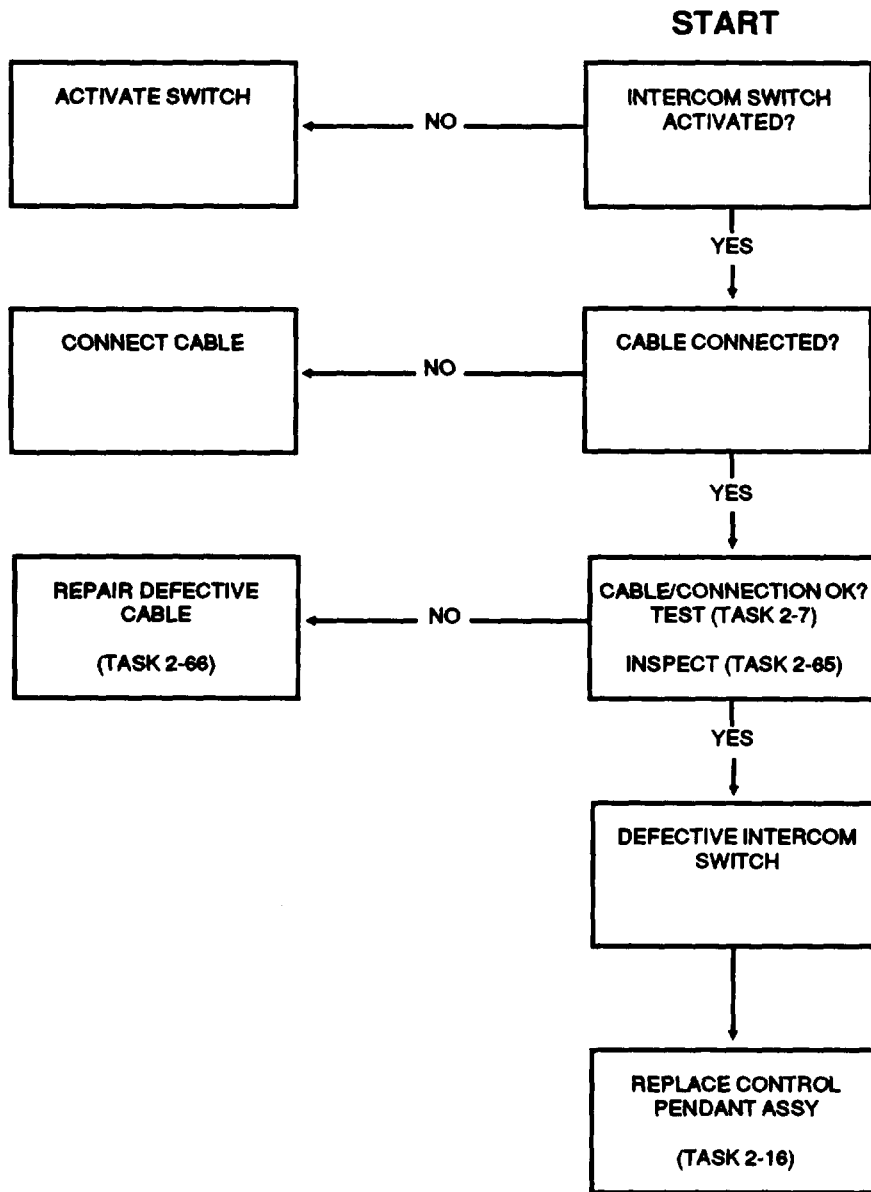
TROUBLESHOOTING PROCEDURE 14. BOOM HEAD ASSY OVERHEATS



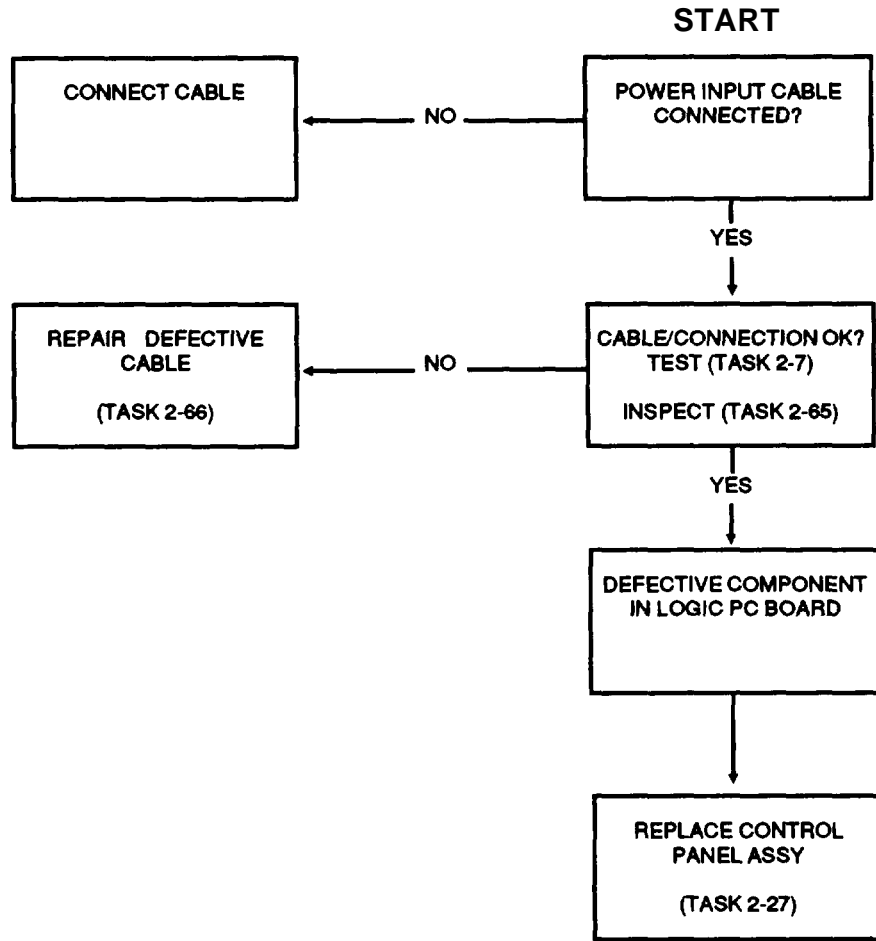
TROUBLESHOOTING PROCEDURE 15. TEMP WARNING LAMP DOES NOT ILLUMINATE, COMPONENT OVERHEATING



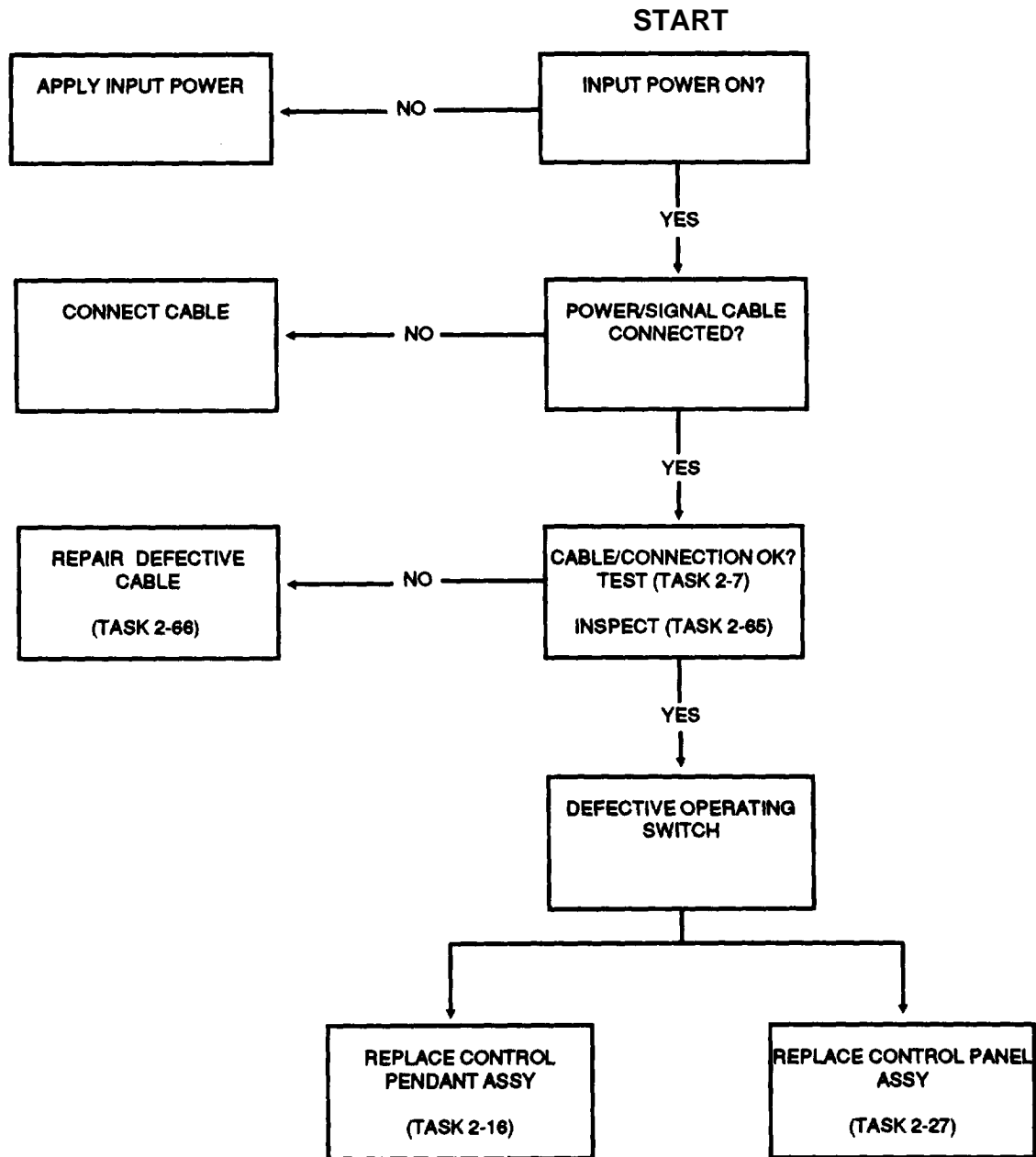
TROUBLESHOOTING PROCEDURE 16. INTERCOM INOPERATIVE



TROUBLESHOOTING PROCEDURE 17. PILOTS OVERRIDE CONTROLS INOPERATIVE



TROUBLESHOOTING PROCEDURE 18. OPERATING CONTROL SWITCH INOPERATIVE



Section V. MAINTENANCE PROCEDURES

2-11. RESCUE HOIST - INSPECT**2-11****This task covers: Inspection****INITIAL SETUP****Personnel Required:**

67N, UH1 Helicopter Repairer
 67T, UH60 Helicopter Repairer
 91W, Medevac Medics

Equipment Condition:

Hoist installed in helicopter
 or assembly stand

Parts/Materials:

None

Equipment Condition Para:

Task 2-5

Tools and Test Equipment:

None

References:

Avionic Cleaning and Corrosion Prevention/Control
 TM 55-1500-343-23

NOTE

All rescue hoist parts shall be visually inspected for defects or damage. Parts which are designated for replacement at each overhaul need not be inspected. If such parts show obvious damage, a note shall be made to inspect mating or adjacent parts during component disassembly.

NOTE

Normally, detailed inspection of individual parts should not be attempted until parts have been disassembled and cleaned (refer to appropriate maintenance task). However, some evidences of exercise wear or malfunction can best be observed during disassembly, when mating or adjacent parts are next to each other. If a part is seen to be galled, scored pitted, or worn, visually inspect mating surfaces of adjacent parts for possible cause of damage.

1. Refer to table 2-3 for inspection definitions and criteria
2. Inspect all parts for nicks, cracks, scratches and dents. Inspect for burrs and scoring on component surfaces.
3. Inspect for corrosion in accordance with TM 55-1500-343-23. Inspect for pitting in metal surfaces and evidence of leakage.
4. Inspect all painted and plated surfaces for blisters or flaking. Plating must be continuous.

GO TO NEXT PAGE

5. Inspect electrical components for corrosion and damage. Check for evidence of overheating and shorting, Inspect electrical wiring for frayed and broken insulation. Check for cuts and tears. Inspect electrical connectors for bent, broken and missing pins.
6. Inspect identification and lubrication plates for legibility and security of attachment.

Table 2-3. INSPECTION REQUIREMENTS

NOTE

Minor component defects (small scratches, minor dents, etc.) are acceptable in some cases, providing the defect does not effect t& performance of the component. It is up to the user to determine whether a defect is acceptable, whether minor repair can return the component to use, or whether the component should be discarded and replaced.

- Burr - A small, thin section of metal extending beyond a regular surface, usually located at the comer or edge of a bore or hole. Burr shall be removed to prevent injury to personnel and damage to adjacent components, and resulting scratch or score shall be repaired,
- Corrosion - Loss of metal from a surface by chemical or electrochemical action. Corrosion products are usually easily removed by mechanical means. Refer to Avionic Cleaning and Corrosion Prevention manual for corrosion identification, removal, and surface refinish.
- crack - A physical separation of two adjacent portions of metal, evidenced by a fine or thin line that crosses surface. Caused by excessive stress, it may extend inward from surface a few thousandths of an inch, or run completely t.hrough section thickness. Cracks pose a serious threat to component operation and may cause injury to operator. Cracks must be repaired immediately. Extensively cracked surfaces shall result in component replacement.
- Dent - Indentation in metal surface produced by an object striking with force. The surface surrounding the indentation will usually be slightly upset. Dents may be removed providing the repair does not structurally weaken component. Minor dents may be left in surface if they do not rub against or contact adjacent parts.
- Nick - Local break or notch on edge. Usually displacement of metal rather than loss. Nick shall be blended into surface, or removed if blending proves impossible.
- Pitting - Sharp, localized breakdown of metal surface. Usually with defined edges, may result in a small, deep cavity, Refer to Avionic Cleaning and Corrosion Prevention manual for pitting identification, removal, and surface refinish.

GO TO NEXT PAGE

2-11. RESCUE HOIST - INSPECT (Cont)

2-11

Table 2-3. INSPECTION REQUIREMENTS (cont)

Scratch - Slight tear or break in metal surface caused by light, momentary contact with foreign material. Scratches shall be blended to remove sharp edges and prevent injury to personnel. If scratch mars adjacent surface, both components shall be replaced.

Scratch - Tear or break in metal surface caused by contact under pressure. Deeper than scratch. May show discoloration from temperature produced by friction. Scoring may be a sign of much larger problems. Carefully inspect mating and adjacent components for damage. Inspect area for cause of damage and remedy prior to next operation. Repair minor surface scoring. Replace component if scoring is extensive, or if component is causing damage to other parts.

Broken wires - broken wires occur as a result of cable damage or as a cable is nearing the end of its service life.

Kinks - a kink is identified as a permanent bend in a cable caused when a loop of cable is suddenly pulled tight. A kink may open a lay of cable and result interference and early failure of the cable caused by abrasion and/or wire breakage. A kinked cable must be replaced.

Bird caging - bird cages are defined as short lengths of wire rope with outer wire strands stretched and opened to be formed in the appearance of a bird cage. A bird cage is a permanent deformation and the cable must be replaced.

Flattened areas - flattened areas of cable result from the application of an excessive force to a small area of the cable. Such damage can be caused by trapping the cable in a door or driving a vehicle with a metallic wheel over the cable. A cable with a flattened area must be replaced.

Abrasion - abrasion is defined as wear of individual wire resulting in flattened areas on the wire. Abrasive wear can be caused by interference with other components, dragging the cable over abrasive surfaces or as a result of other cable damage. Cable which have abrasive damage must be replaced and, if applicable, the cause of the abrasion must be investigated and repaired.

Necking - necking is defined as the decrease in cable diameter at specific point. Necking is normally an indication of broken wires and is cause for cable replacement.

FOLLOW-ON MAINTENANCE:

Repair rescue hoist
(Task 2-14)

END OF TASK

This task covers: Testing

INITIAL SETUP

Personnel Rewired:

67N, UH1 Helicopter Repairer
67T, UH60 Helicopter Repairer
91W, Medevac Medics

Equipment Condition:

Hoist installed in helicopter

Parts/Materials:

None

Equipment Condition Para:

Task 2-5

Tools and Test Equipment:

None

References:

None

Testing of the rescue hoist consists of conducting operational performance check in accordance with Task 2-7.

FOLLOW-ON MAINTENANCE:

None

END OF TASK

2-13. RESCUE HOIST - SERVICE

2-13

This task covers: Servicing

INITIAL SETUP**Personnel Required:**

67N, UH1 Helicopter Repairer
67T, UH60 Helicopter Repairer
91W, Medevac Medics

Equipment Condition:

Hoist installed in **helicopter**

Parts/Materials:

Hydraulic Fluid (Item 13, App. D)

Equipment Condition Para:

Task 2-5

Tools and Test Equipment:

Tool Set, Aviation Unit Maintenance
NSN 4920-00-567-0476
Tool Kit, Aircraft Mechanic
NSN 5180-00-323-4692

References:

None

Service hoist in accordance with procedures outlined in Tasks 2-18 and 2-46. Recheck lubricating oil levels after any hoist maintenance procedures are performed.

FOLLOW-ON MAINTENANCE:

None

END OF TASK

2-14. RESCUE HOIST - REPAIR

2-14

This task covers: **Repair**

INITIAL SETUP**Personnel Required:**

67N, UH1 Helicopter Repairer
67T, UH60 Helicopter Repairer
68F, Aircraft Electrical Repairer
91W, Medevac Medics

Equipment Condition:

Hoist installed in assembly stand

Parts Materials:

None

Equipment Condition Para:

Task 2-5

Tools and Test Equipment:

Tool Set, Aviation Unit Maintenance
NSN 4920-00-567-0476
Tool Kit, Electrical Repairer
NSN 5180-00-323-4915
Multimeter

References:

Avionic Cleaning and Corrosion Prevention/Control
TM 55-1500-343-23
Aircraft Weapons Systems Cleaning and Corrosion Control
TM 55-1500-344-23

Repair of rescue hoist consists of removal, repair and installation of hoist components. Refer to specific tasks (2-15 thru 2-67) for aviation unit maintenance repair.

FOLLOW-ON MAINTENANCE:

Install hoist in helicopter
(Task 2-5)

END OF TASK

2-15. CONTROL PENDANT ASSEMBLY-INSPECT

2-15

This task covers: Inspection**INITIAL SETUP****Personnel Required:**

67N, UH1 Helicopter Repairer
 67T, UH60 Helicopter Repairer
 91W, Medevac Medics

Equipment Condition:

Hoist installed in assembly stand
 Control pendant removed

Parts/Materials:

None

Equipment Condition Para:

Task 2-5
 Task 2-16

Tools and Test Equipment:

None

References:

None

-
1. Inspect control pendant for nicks, cracks, dents and gouges. Inspect for corrosion. (Refer to Task **2-11**)
 2. Inspect control cable for cuts, tears, fraying and broken insulation,
 3. Inspect cable connector for bent, broken and missing pins. Check for crossed stripped and damaged threads.
 4. Ensure operational switches operate smoothly, free of binding and sticking.
 5. Inspect identification plate for legibility and security of attachment.

FOLLOW-ON MAINTENANCE:

Replace control pendant
 (Task 2-16)

END OF TASK

This task covers: Removal and Installation

INITIAL SETUP

Personnel Required:

67N, UH1 Helicopter Repairer
 67T, UH60 Helicopter Repairer
 91W, Medevac Medics

Equipment Condition:

Hoist installed in helicopter
 or assembly stand

Parts/Materials:

None

Equipment Condition Para:

Task 2-5

Tools and Test Equipment:

None

References:

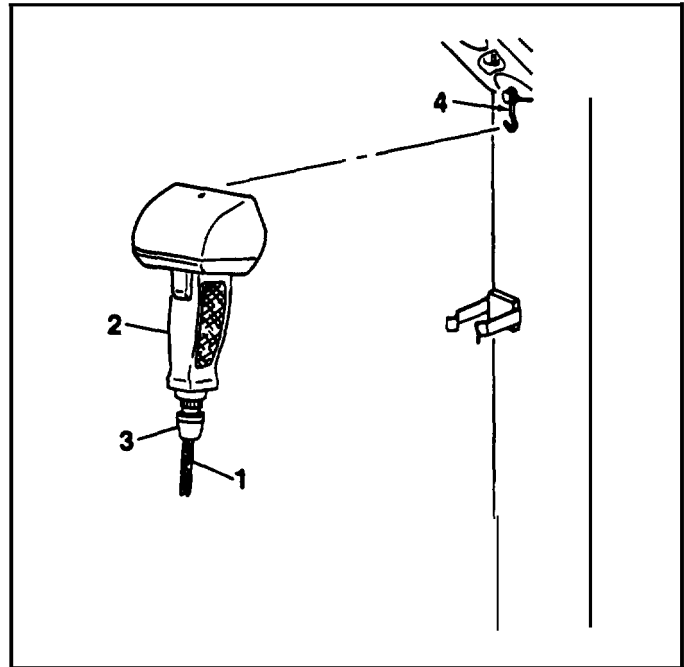
None

1. Removal.

WARNING

Ensure external electrical power is removed from system prior to removing control cable, Personnel injury could occur.

- a. Disconnect control cable (1) from control pendant (2) by unscrewing connector (3).
- b. Remove control pendant (2) from hook (4).

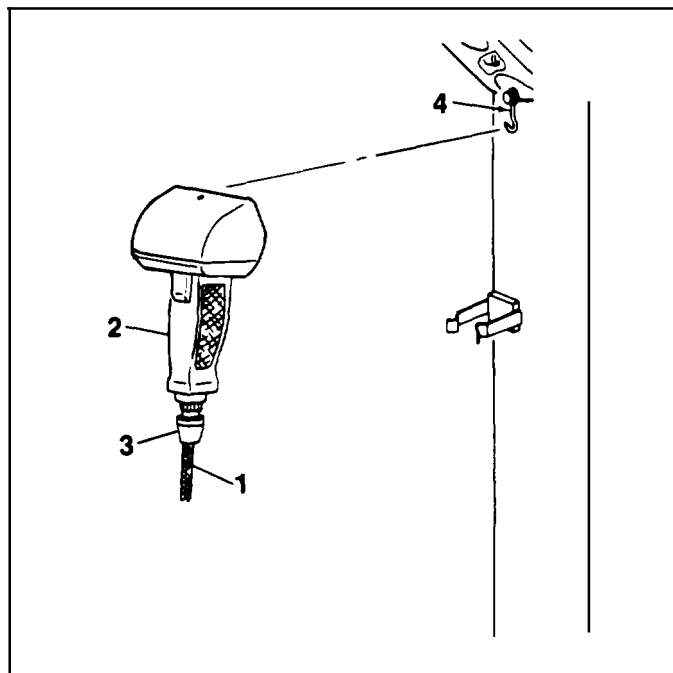


GO TO NEXT PAGE

2-16. CONTROL PENDANT - REPLACE (cont)**2-16****2. Installation.****WARNING**

Ensure external electrical power is removed from system prior to removing control cable. Personnel injury could occur.

- a. Mate control cable connector (3) to control pendant (2) and screw on.
- b. Ensure cable (1) and connector (3) are properly secured.
- c. Place control pendant (2) onto hook (4).

**FOLLOW-ON MAINTENANCE:**

conduct operational performance
check
(Task 2-7)

END OF TASK

2-17. BOOM HEAD ASSEMBLY - INSPECT

2-17

This task covers: Inspection**INITIAL SETUP****Personnel Required:**

67N, UH1 Helicopter Repairer
 67T, UH60 Helicopter Repairer
 91W, Medevac Medics

Parts/Materials:

None

Tools and Test Equipment:

None

Equipment Condition:

Hoist installed in helicopter or assembly stand

Equipment Condition Para:

Task 2-5

References

None

1. Inspect boom head assembly for nicks, cracks, scratches and dents. Inspect for corrosion. (Refer to Task 2-11).
2. Inspect for evidence of oil leakage.
3. Inspect cable cutter and switch harness assembly for cuts, tears, fraying and broken insulation.
4. Inspect electrical connectors for bent, broken and missing pins. Check for crossed, stripped and damaged threads.
5. Inspect identification and lubrication plates for legibility and security of attachment.
6. Check boom head for freedom of movement.
7. Check boom head fluid level.

FOLLOW-ON MAINTENANCE:

Repair boom head assembly
 (Task 2-19)

END OF TASK

2-18. BOOM HEAD ASSEMBLY - SERVICE

2-18

This task covers: Draining and Servicing

INITIAL SETUP**Personnel Required:**

67N, UH1 Helicopter Repairer
67T, UH60 Helicopter Repairer
91W, Medevac Medics

Equipment Condition:

Hoist installed in assembly stand

Parts/Materials:

Automatic Transmission Fluid (Item 3,
App. D)
Lockwire (Item 18, App. D)
Packing, **MS28775-O10**

Equipment Condition Para:

Task 2-5

Tools and Test Equipment:

Tool Set, Aviation Unit Maintenance
NSN 4920-00-567-0\$76
Tool Kit, Aircraft Mechanic
NSN **5180-00323-4692**

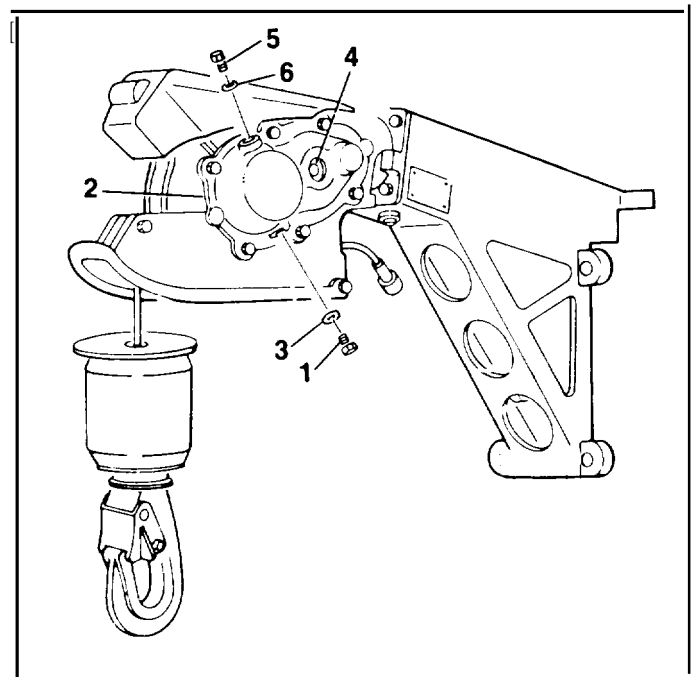
References:

None

1. Draining**NOTE**

Before removing boom head drain plugs, place container below boom head to catch fluid.

- a. Remove lockwire from drain plugs (1) and discard. Remove drain plugs from side covers (2) and allow fluid to drain.
- b. Remove and discard packings (3). Lubricate new packings and install onto drain plugs (1). Install plugs into side covers (2) and secure using lockwire.



GO TO NEXT PAGE

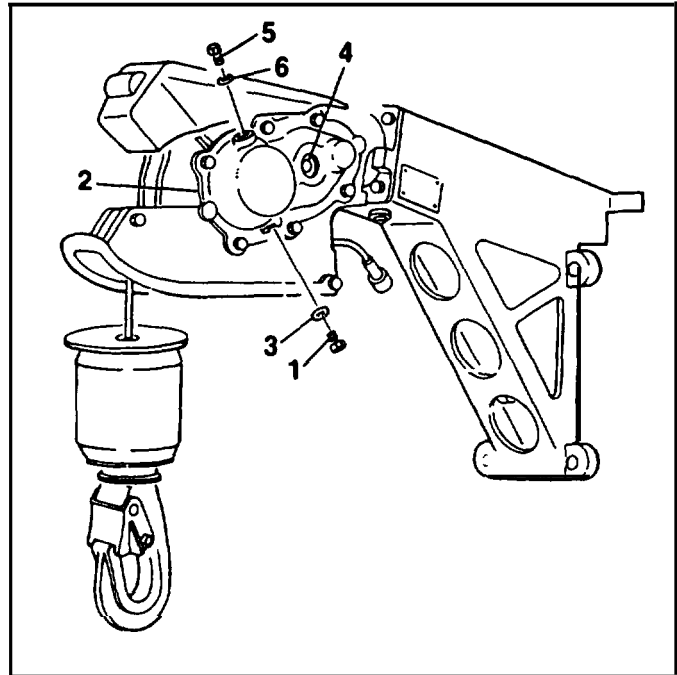
2. Servicing.

- a. Inspect fluid level through sight glass (4).
- b. Remove servicing plugs (5) from boom head aide covers (2). Remove and discard packings (6).

NOTE

Service boom head assembly with MIL-H-5606 oil for operation below -40° F.

- c. Service boom head assembly to full mark using automatic transmission fluid.
- d. Recheck fluid level through sight glass (4).
- e. Lubricate new packings (6) and install onto servicing plugs (5). Install servicing plugs into aide covers (2) and secure using lockwire.



FOLLOW-ON MAINTENANCE:

None

END OF TASK

2-19. BOOM HEAD ASSEMBLY - REPAIR

2-19

This task covers: **Disassembly, Cleaning, Inspection, Repair and Reassembly**

INITIAL SETUP**Personnel Required:**

67N, UH1 Helicopter Repairer
67T, UH60 Helicopter Repairer
91W, Medevac Medics

Parts/Materials:

Abrasive Cloth, Aluminum Oxide (Item 1,
App. D)
Adhesive, RTV-732 (Item 2, App. D)
Cleaning Solvent (Item 10, App. D)
Trichloroethane (Item 25, App. D)

Tools and Test Equipment:

Tool Set, Aviation Unit Maintenance
NSN 4920-00-567-0476
Tool Kit, Aircraft Mechanic
NSN 5180-00-323-4692
Air Source, 35 psi
Micrometer
Assembly Stand, 42277-808 or
equivalent

Equipment Condition:

Hoist installed in assembly stand
Boom head assembly removed

Equipment Condition Para:

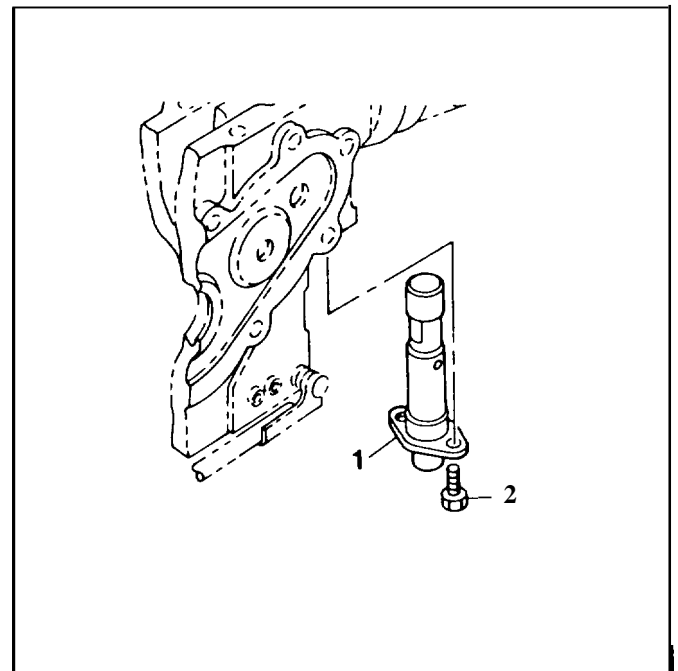
Task 2-5
Task 2-20

References:

Avionic Cleaning and Corrosion Prevention/Control
TM 55-1500-343-23
Aircraft Weapons Systems Cleaning and Corrosion Control
TM 55-1500-344-23

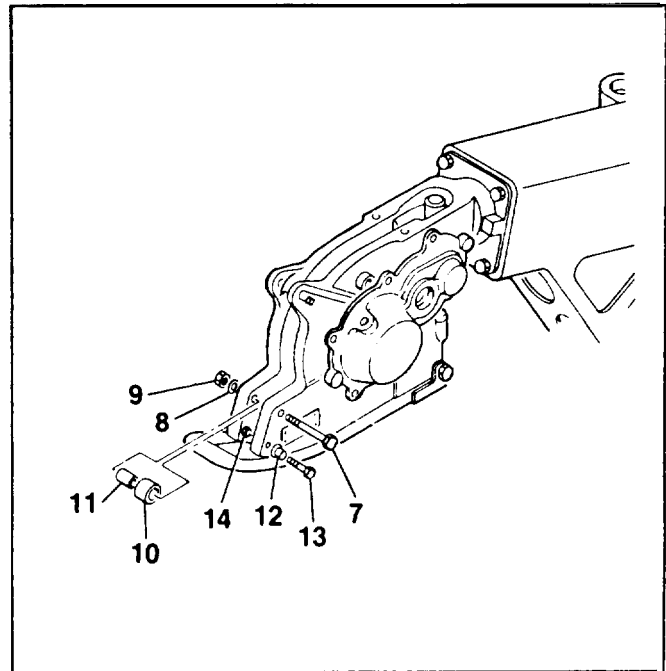
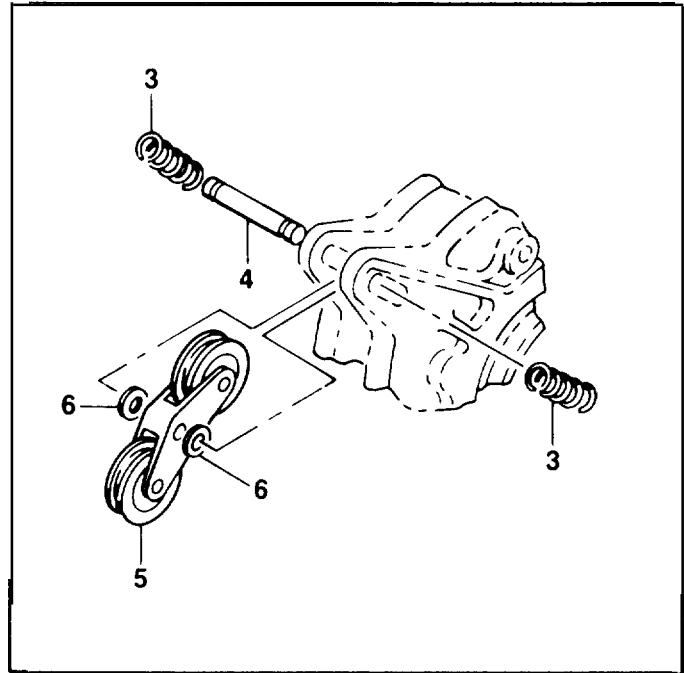
1. Disassembly.

- a. Remove cable cutter (1) by removing bolts (2).



GO TO NEXT PAGE

- b . Remove extension springs (3) from pressure roller shaft (4).
- c . Remove roller shaft (4), pressure roller assembly (5) and washers (6).
- d . Remove bolt (7), washer (8) and nut (9). Remove spacer (10) and guide (11).
- e . Remove actuator atop (12) by removing screw (13) and nut (14).

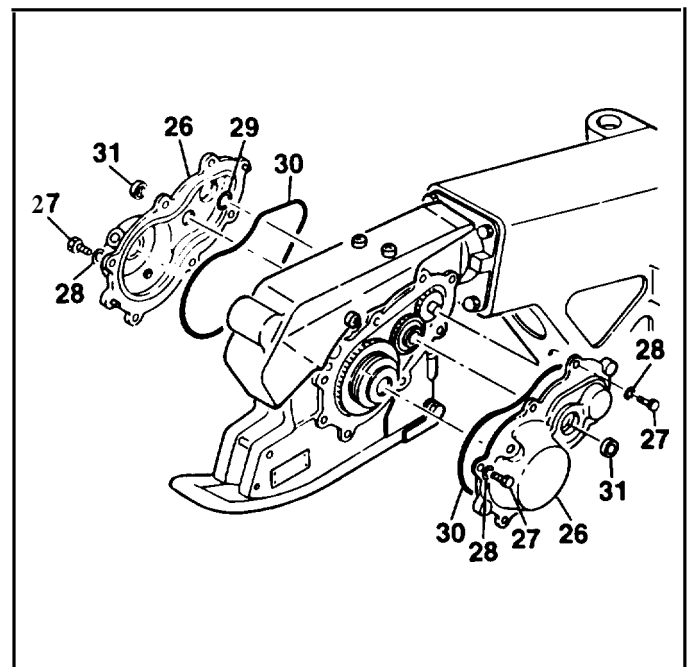
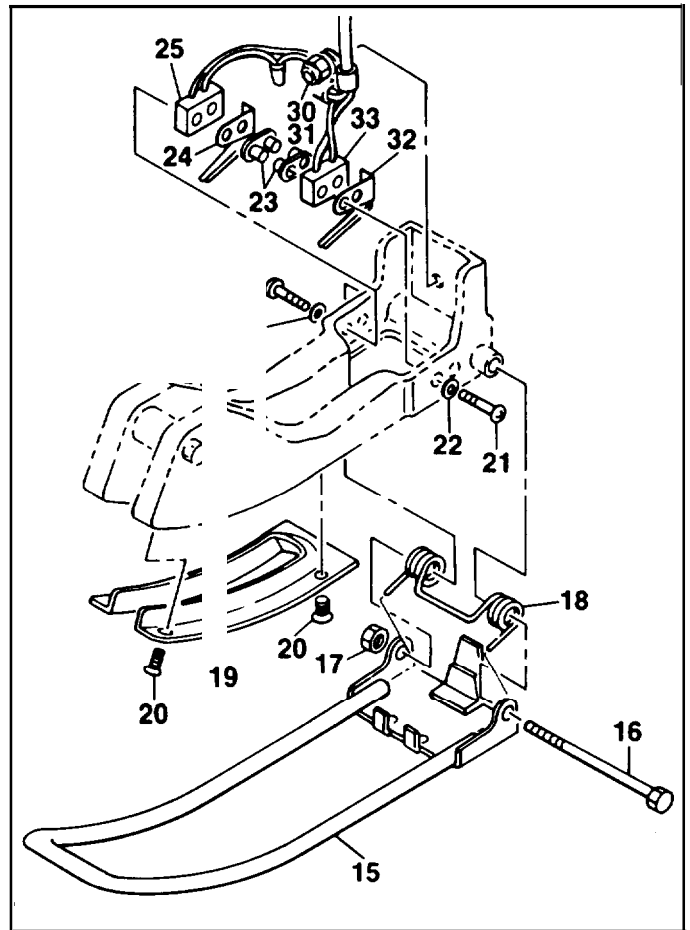


GO TO NEXT PAGE

2-19. BOOM HEAD ASSEMBLY - REPAIR (cont)

2-19

- f. Remove actuator assembly (15) by removing bolt (16) and nut (17). Remove spring (18).
- g. Remove cable guide (19) by removing screws (20).
- h. Remove screws (21), washers (22) and nut-plates (23).
- i. Carefully remove actuator leaves (24) from microswitch assemblies (25).
- j. Remove side cover assemblies (26) by removing bolts (27) and washers (28). Remove shims (29) from bearing bores of covers.
- k. Remove and discard packings (30) from covers (26).
- l. Remove sight plugs (31), as required, using a small drive pin.



GO TO NEXT PAGE

2. Cleaning.**WARNING**

Use solvent in a well ventilated area. Avoid prolonged breathing of fume. Keep away from open flame. Use approved safety equipment.

WARNING

Use approved personnel protective equipment (goggles /face shield) when using compressed air. Air pressure is restricted to 35 psi. Do not direct airstream towards self or other personnel as injury may occur.

CAUTION

Do not immerse electrical components in cleaning solvent. Wipe clean with a cloth dampened in soap and water solution.

CAUTION

If parts are not to be inspected immediately after cleaning, dip them in preservation oil to prevent rust spots.

- a. Clean electrical connectors in accordance with TM 55-1500-343-23.
- b. Wash remaining components in solvent and rinse thoroughly. Dry with compressed air.

3. Inspection.

- a. Inspect all parts for nicks, cracks, scratches and dents (refer to Task 2-11).
- b. Inspect for corrosion (refer to Task 2-11) and evidence of leakage.
- c. Inspect all threaded parts for crossed, stripped and damaged threads,
- d. Inspect electrical wiring for frayed and broken insulation. Check for cuts and tears.
- e. Inspect electrical connectors for bent, broken and missing pins. Inspect for evidence of overheating and shorting.
- f. Inspect identification and lubrication plates for legibility and security of attachment.
- g. Side cover gear pin shaft boss ID shall be 0.6253 to 0.6260 in. (15.883-15.900 mm)

GO TO NEXT PAGE

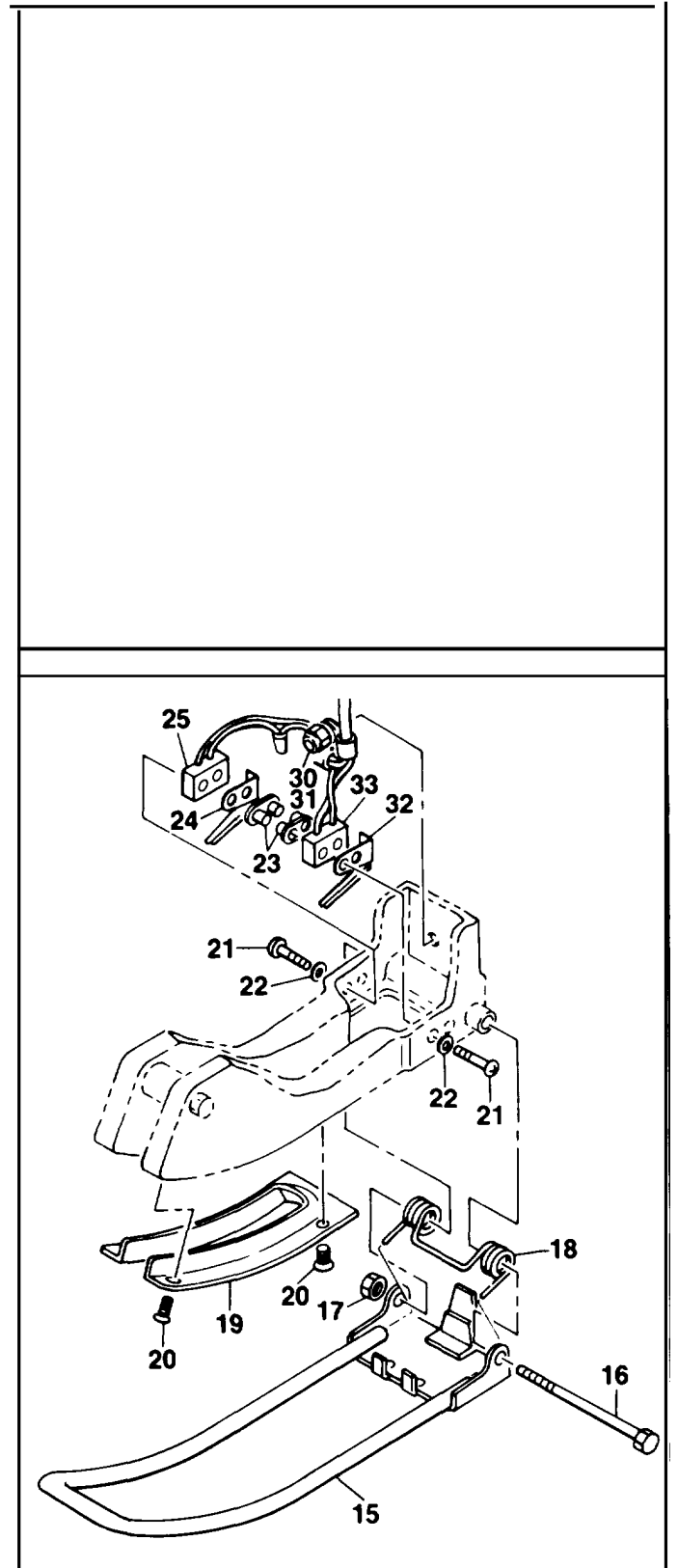
2-19. BOOM HEAD ASSEMBLY - REPAIR (cont)

2-19

4. **Repair.** Repair of parts is limited to the removal of minor nicks, burrs, scratches or other surface damage using aluminum oxide cloth or fine abrasive. Clean parts thoroughly after repair. If damage is extensive, or if minor repair will affect serviceability, replace the part.

5. **Reassembly.**

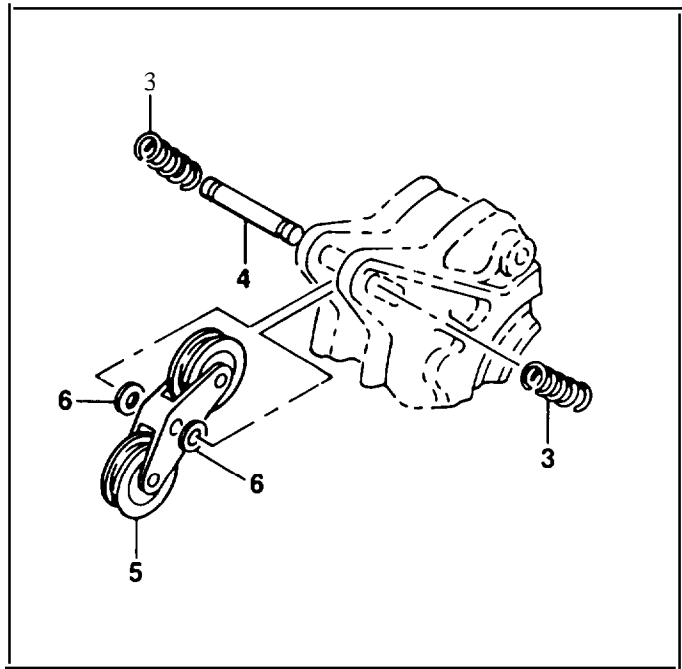
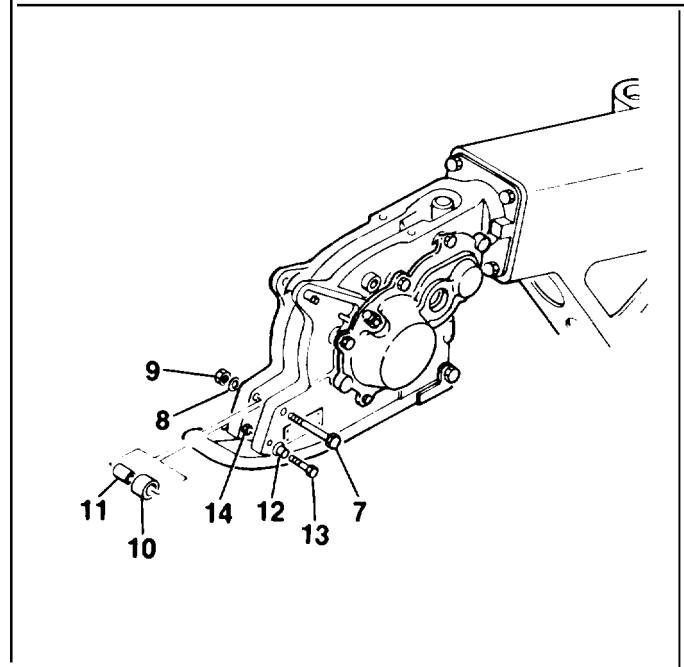
- a. Coat sight plugs (31) with RTV-732 sealant and install.
- b. Lubricate packings (30) oil and install onto side covers (26).
- c. Install (29) into bearing bore of cover (26).
- d. Position side cover assemblies (26), ensuring proper packing seat. Secure using bolts (27) and washers (28).
- e. Install actuator leaves (24) and position with microswitch assemblies (25) and boom housing.
- f. Install screws (21), washers (22) and nutplates (23).
- g. Install cable guide (19) using screws (20).
- h. Position spring (18) onto boom head boss, ensuring snug fit.
- i. Position actuator assembly (15) to beam head housing. Fit bolt (16) through actuator assembly and spring (18). Secure using nut (17).
- j. Adjust actuator assembly (Task 2-24).



GO TO NEXT PAGE

2-19. BOOM HEAD ASSEMBLY - REPAIR (cont)

- k. Install actuator stop (12) using screw (13) and nut (14).
- l. Position spacer (10) and guide (11). Install bolt (7), washer (8) and nut (9).
- m. Install roller shaft (4), pressure roller assembly (5) and washers (6).
- n. Install extension springs (3) onto roller shaft (4).



GO TO NEXT PAGE

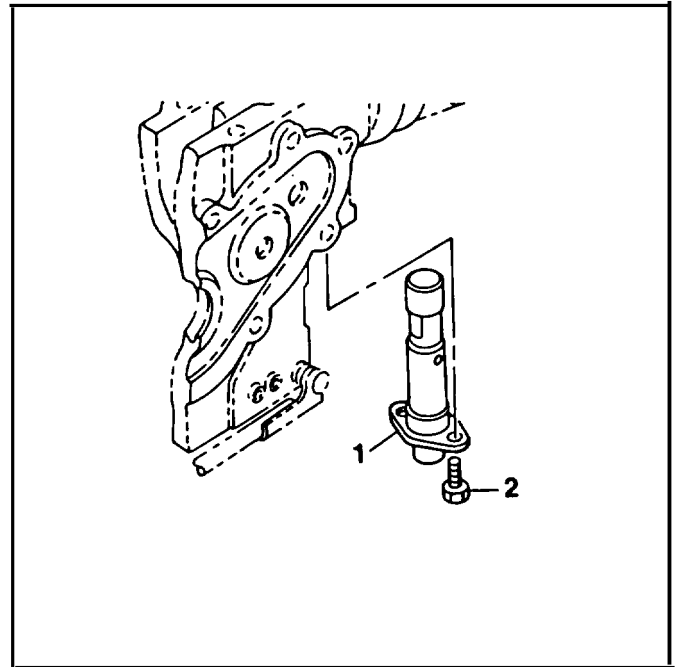
WARNING

Rescue hoist cable cutter contains an explosive cartridge. Use extreme care when handling to prevent injury to personnel.

- o. Install cable cutter (1) using bolts (2).

FOLLOW-ON MAINTENANCE:

Replace boom head assembly
(Task 2-20)



END OF TASK

This task covers: Removal and Installation

INITIAL SETUP

Personnel Required:

67N, UH1 Helicopter Repairer (2)
67T, UH60 Helicopter Repairer (2)
91W, Medevac Medics

Equipment Condition:

Hoist installed in assembly stand
Boom head assembly drained
Cable assembly removed

Parts/Materials:

Lockwire (Item 18, App. D)

Equipment Condition Para:

Task 2-5
Task 2-18
Task 2-60

Tools and Test Equipment:

Tool Set, Aviation Unit Maintenance
NSN 4920-00-567-0476

References:

None

GO TO NEXT PAGE

2-20. BOOM HEAD ASSEMBLY - REPLACE (cont)

2-20

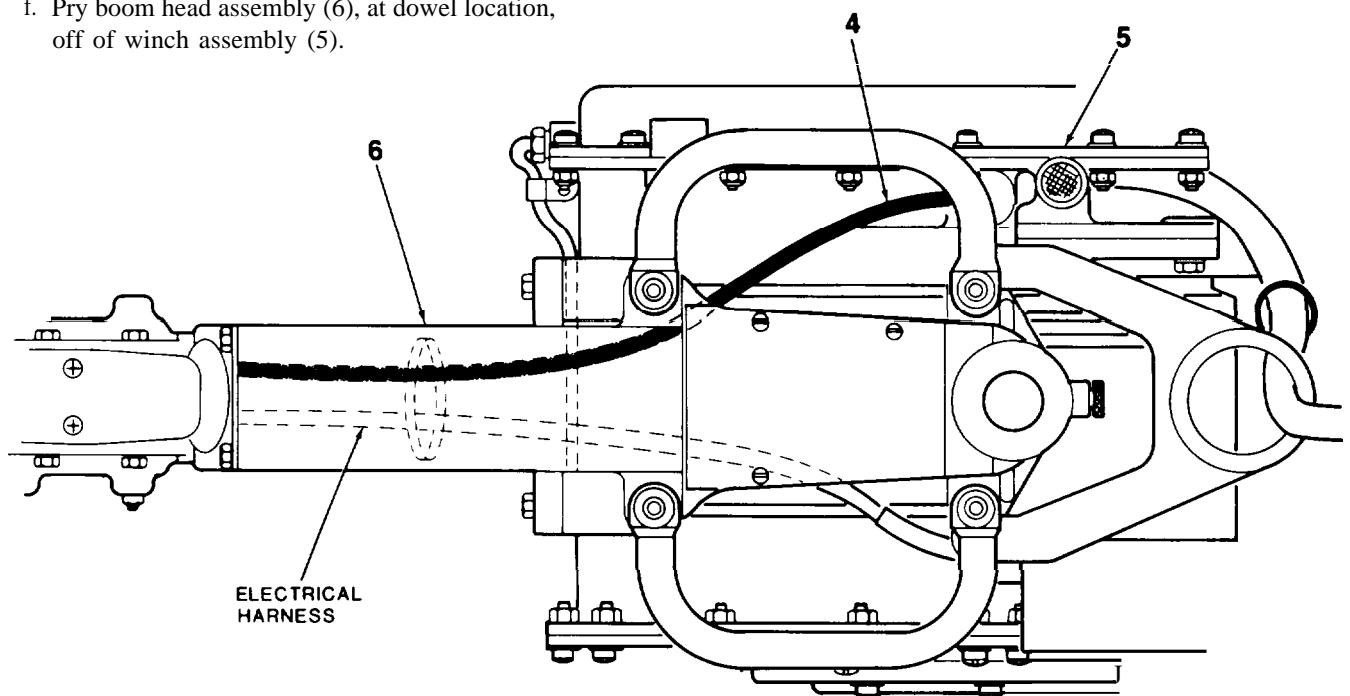
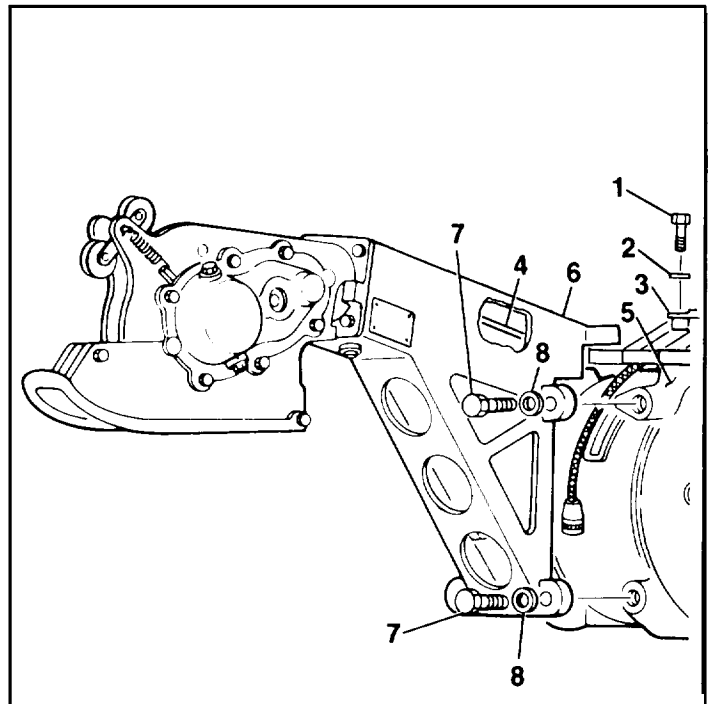
1. **Removal.**

- a. Remove forward bolts (1) and washers (2) from handles (3). Loosen rear bolts (1) and swing handles outboard.
- b. Remove lockwire and disconnect flexible drive shaft (4) from winch (5).
- c. Disconnect electrical harnesses as required to remove boom head assembly.

WARNING

Enlist the help of an aide to support boom head assembly during removal to prevent injury to personnel and damage to equipment.

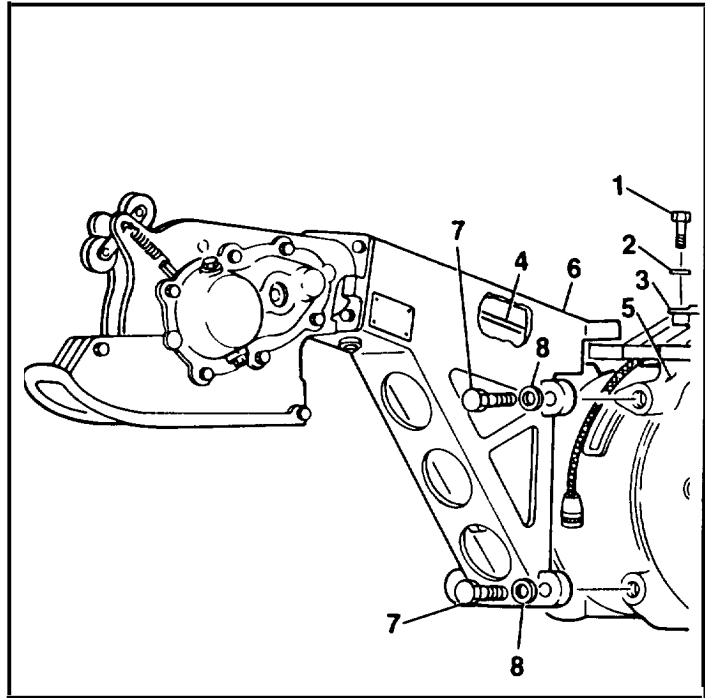
- d. Remove boom head assembly (6) by removing bobs (7) and washers (8).
- e. Lift up on upper support assembly to allow clearance for flexible drive shaft (4) during boom head removal.
- f. Pry boom head assembly (6), at dowel location, off of winch assembly (5).



GO TO NEXT PAGE

2. Installation.

- a. Lift up on upper support assembly to allow clearance for flexible drive shaft (4) during boom head installation.
- b. Position boom head assembly (6) against winch (5). Secure using bolts (7) and washers (8).
- c. Torque bolts (7) to 160-190 in.lbs.
- d. Connect flexible drive shaft (4) to winch (5).
- e. Swing handle (3) inboard and position. Tighten rear bolts (1) and install front bolts and washers (2).
- f. Torque bolts (1) to 160-190 in.lbs.
- g. Connect electrical harnesses.



FOLLOW-ON MAINTENANCE:

- Install** cable
(Task 2-60)
- Service boom head assembly
(Task 2-18)
- conduct performance check
Task 2-7)

END OF TASK

2-21. CABLE CUTTER ASSEMBLY - INSPECT

2-21

This task covers: Inspection

INITIAL SETUP**Personnel Required:**

67N, UH1 Helicopter Repairer
 67T, UH60 Helicopter Repairer
 91W, Medevac Medics

Equipment Condition:

Hoist installed in helicopter
 or assembly stand
Cable cutter removed

Parts/Materials:

None

Equipment Condition Para:

Task 2-5
 Task 2-22

Tools and Test Equipment:

None

References:

None

WARNING

Rescue hoist cable cutter contains an explosive cartridge. Use extreme care when handling to prevent injury to personnel. Static producing clothing prohibited. When disconnecting harness, install piece of aluminum foil between cartridge pins and install shipping cap.

1. Inspect for corrosion (refer to Task 2-11).
2. Inspect cable cutter electrical connector for bent, broken and missing pins. Inspect for evidence of overheating.
3. Inspect electrical cable for frayed and broken insulation. Check for cuts and tears.

FOLLOW-ON MAINTENANCE:

Install cable cutter assembly
 Task 2-22)

END OF TASK

This task covers: Removal and Installation

INITIAL SETUP

Personnel Required

67N, UH1 Helicopter Repairer
 67T, UH60 Helicopter Repairer
 91W, Medevac Medics

Tools and Test Equipment:

Tool Set, Aviation Unit Maintenance
 NSN 4920-00-567-0476

Equipment Condition

Hoist installed in assembly stand.
 Pressure roller cover removed.

Equipment Condition Para:

Task 2-5
 Task 2-20

1. R e m o v a l .

WARNING

Rescue hoist cable cutter contains an explosive cartridge. Use extreme care when handling to prevent injury to personnel. Static producing clothing prohibited. Install aluminum foil shorting strips between cartridge pins when disconnecting harness.

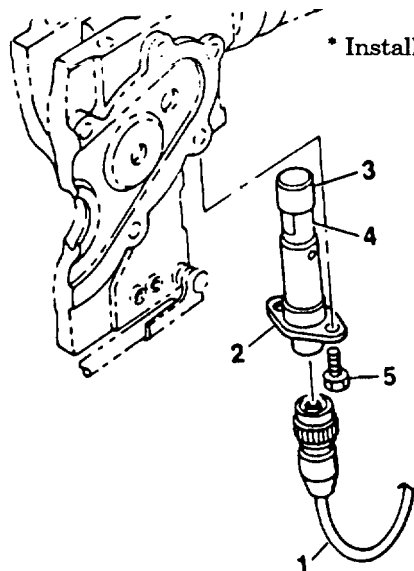
- a. Disconnect cable cutter harness (1) from cable cutter (2).
- b. Remove cap (3) and anvil (4) from cable cutter (2).
- c. Remove cable cutter (2) by removing bolts (5).

2. I n s t a l l a t i o n

WARNING

Rescue hoist cable cutter contains an explosive cartridge. Use extreme care when handling to prevent injury to personnel. Static producing clothing prohibited.

- a. Install cable cutter (2) using bolts (5).
- b. Install anvil (4) and cap (3) onto cable cutter (2).
- c. Connect cable cutter harness (1) to cable cutter (2).



* Install Pressure Roller Cover (Task 2-20).

END OF TASK

2-22.A. CABLE CUTTER ASSEMBLY - REPAIR

2-22.A.**This task covers: Disassembly and Assembly****INITIAL SETUP****Personnel Required:**

67N, UH1 Helicopter Repairer
67T, UH60 Helicopter Repairer
91W, Medevac Medics

Parts/Materials:

Abrasive Cloth (Item 1, App. D)
Cleaning Solvent (Item 10, App. D)
Petrolatum (Item 19, App. D)
Lockwire (Item 17, App. D)

Tools and Test Equipment:

Tool Set, Aviation Unit Maintenance
NSN 4920-00-567-0467

Equipment Condition:

Hoist installed in Assembly.
Stand Cable Cutter Assembly removed.

Equipment Condition Para:

Task 2-5
Task 2-22

References:

None

GO TO NEXT PAGE

NOTE

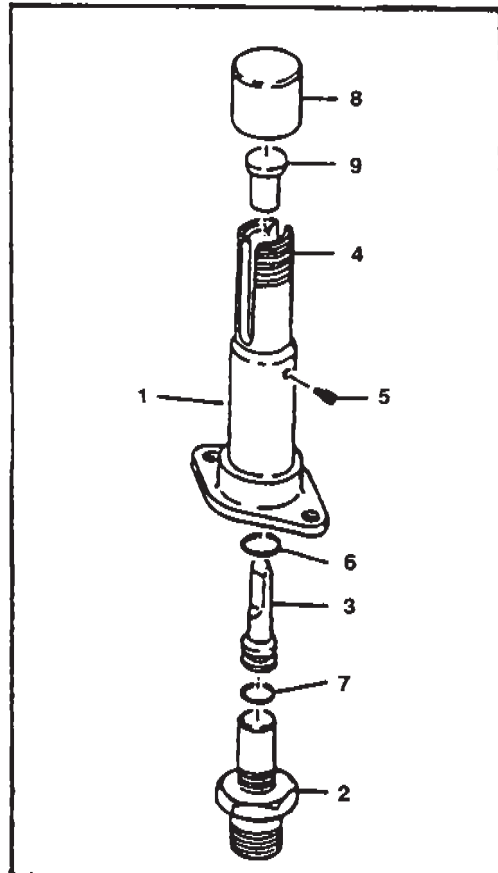
After activation, the cable cutter assembly must be repaired (rebuilt) prior to installing the new cable cutter assembly.

NOTE

The cartridge has a combined "shelf life" and installed life of not more than six years from date of manufacture. The maximum installed life is three years. Cartridge replacement is mandatory when the maximum combined shelf and installed life of six years or max. installed life has expired. Discarded cartridge is to be disposed of IAW DOD and army regulations governing the disposal of munitions. Perform step A for cartridge replacement only. Due to expiration of cartridge service life.

1. **Disassembly.**

- a. Cut lockwire and remove cartridge (2) from Cable Cutter Assembly (1). Discard cartridge (2).



GO TO NEXT PAGE

2-22.A. CABLE CUTTER ASSEMBLY - REPAIR (cont)

2-22.A

NOTE

Cap (8) and anvil (9) were removed in Task 2-22. Discard expended anvil (9) and retain cap (8) for reinstallation.

- b. Remove and discard shear screw (5).
- c. Insert screwdriver into threaded end of barrel (4) and push cutter (3) from barrel (4).
- d. Remove and discard packing preformed (6) from cutter (3).

2. Cleaning.

- a. Remove corrosion deposits from barrel with crocus cloth.
- b. Clean powder deposits with cloth dampened with solvent.

3. Inspection.

- a. Inspect barrel for corrosion, stripped threads and evidence of damage.
- b. Inspect shear screw bore in barrel for stripped threads and damage.

4. Assembly.

NOTE

The original barrel (4), cap (8) and cable cutter refire kit will be used to re-build the Cable Cutter Assembly.

Check cable cutter refire kit for condition and cartridge date. Date of manufacture should indicate that more than three years remain on cartridge.

WARNING

The cable cutter refire kit, P/N 42277E182 contains an explosive cartridge. Use extreme care when handling to prevent injury to personnel. Static producing clothing prohibited.

- a. Lubricate packing (6) and install on cutter (3).

END OF TASK

- b. Position cutter (3) perpendicular to aperture on barrel (4) and obtain an alignment reference between bore hole on cutter (3) and threaded bore on barrel (4).
- c. Install cutter (3) into barrel (4) and align bore holes.

NOTE

Ensure shear screw (5) head is flushed with barrel (4) surface.

- d. Install shear screw (5).
- e. Lubricate packing (7) and install on cartridge (2).
- f. Install cartridge (2) into barrel (4) and lockwire.

NOTE

Cap (8) and anvil (9) will be installed during Cable Cutter Assembly task.

FOLLOW ON MAINTENANCE:

Install Cable Cutter Assembly (Task 2-22)

This task covers: Inspection

INITIAL SETUP

Personnel Required:

67N, UH1 Helicopter Repairer
67T, UH60 Helicopter Repairer
91W, Medevac Medics

P a r t s / M a t e r i a l s :

None

Tools and Test Equipment:

None

Equipment Condition

Hoist installed in helicopter

Equipment Condition Para:

Task 2-5

References:

None

-
1. Inspect actuator assembly for nicks, cracks, scratches and dents (refer to Task 2-11).
 2. Inspect for corrosion. (Refer to Task 2-11).
 3. Operate actuator arm to ensure smooth operation of spring, free of binding.
 4. Inspect tangs for cracks and damage.

FOLLOW-ON MAINTENANCE:

None

END OF TASK

2-24. ACTUATOR ASSEMBLY (UP LIMIT) - ADJUST

2-24

This task covers: Adjustment**INITIAL SETUP****Personnel Required:**

67N, UH1 Helicopter Repairer
 67T, UH60 Helicopter Repairer
 91W, Medevac Medics

Equipment Condition:

Hoist installed in assembly stand

Parts/Materials:

None

Equipment Condition Para:

Task 2-5

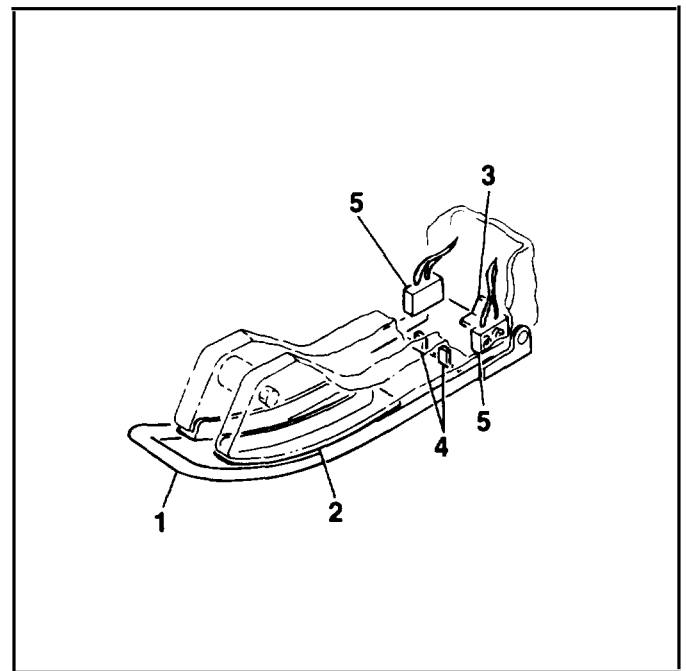
Tools and Test Equipment:

Tool Set, Aviation Unit Maintenance
 NSN 4920-00-567-0476

Reference:

None

1. Using a measuring device, check that the distance between lowered arm of actuator assembly (1) and bottom of cable guide (2) is **0.75 inch (1.91 cm)**.
2. Bend large tang (3) at rear plate of actuator (1) to achieve 0.75 inch (1.91 cm) clearance.
3. Press up on actuator arm (1) until small tangs (4) engage microswitch assemblies(5). Audibly check that both switches engage at same time.
4. Bend small tangs (4) as required to coordinate switch engagement.
5. Press up on actuator arm (1) to engage switches (5). Using measuring device, check that distance between top of arm and cable guide (2) is **0.44 inch (1.18 cm)**.
6. Bend small tangs (4) to achieve 0.44 inch (1.18 cm) clearance.

**FOLLOW-ON MAINTENANCE:**

Test microswitch assembly
 (Task 2-26)

END OF TASK

This task covers: **Removal and Installation**

INITIAL SETUP

Personnel Required:

67N, UH1 Helicopter Repairer
67T, UH60 Helicopter Repairer
91W, Medevac Medics

Equipment Condition:

Hoist installed in assembly stand
Cable hook removed

Parts/Materials:

None

Equipment Condition Para:

Task 2-5
Task 2-58

Tools and Test Equipment:

Tool Set, Aviation Unit Maintenance
NSN 4920-00-567-0476

References:

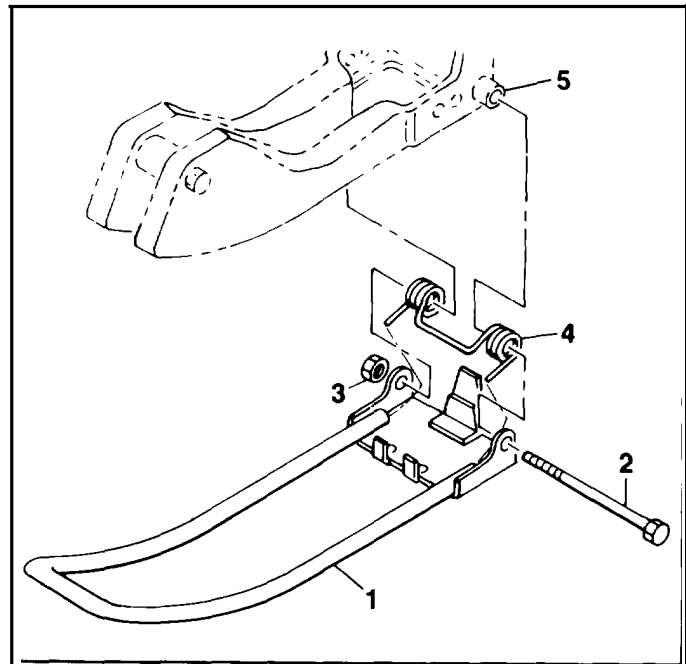
None

1. Removal.

- a. Remove actuator assembly (1) by removing bolt (2) and nut (3).
- b. Remove spring (4) from boom head boss (5).

2. Installation.

- a. Position spring (4) onto boom head boss (5), ensuring snug fit.
- b. Position ends of spring (4) into hollow end of actuator assembly (1) while positioning assembly to boom head housing. Fit bolt (2) through actuator assembly and spring (4). Secure using nut (3).



FOLLOW-ON MAINTENANCE:

Adjust actuator assembly
(Task 2-24)
Install cable hook
(Task 2-58)

END OF TASK

2-26. MICROSWITCH ASSEMBLY (FULL UP) - TEST

2-26

This task covers: Testing**INITIAL SETUP****Personnel Required:**

67N, UH1 Helicopter Repairer
 67T, UH60 Helicopter Repairer
 91W, Medevac Medics

Equipment Condition:

Hoist installed in helicopter

Parts/Materials

None

Equipment Condition Para:

Task 2-5

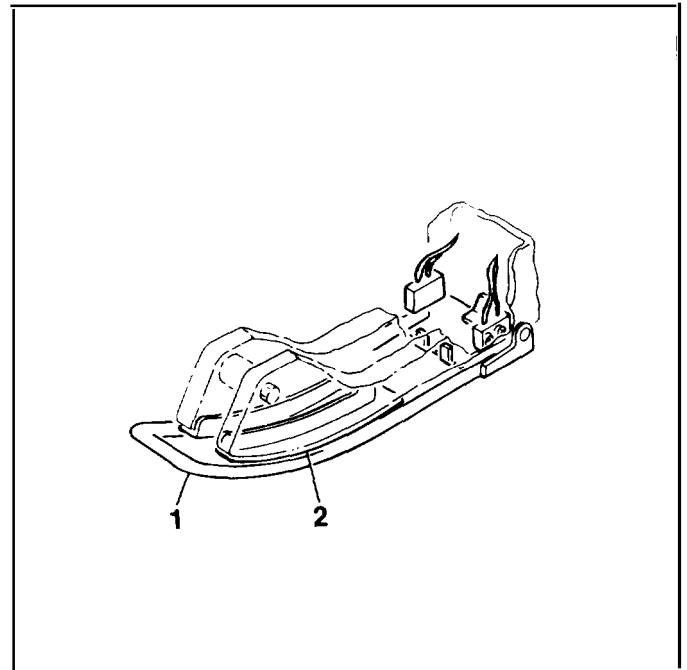
Tools and Test Equipment:

Tool Kit, Aircraft Mechanic
 NSN 5180-00-323-4692
 Ground Power Unit (GPU)

References:

None

1. Apply power to hoist. Position HOIST PWR switch to ON.
2. Move control pendant switch to DWN. Reel out approximately 4 feet (12.19 dm) of cable.
3. Ensure actuator arm (1) moves freely without binding through full range.
4. Ensure distance between lowered actuator arm (1) and bottom of cable guide (2) is **0.75 inch (1.91 cm)**. Adjust as required (Task 2-24).
5. Slowly move control pendant switch to UP position and reel in cable. Ensure cable hook contacts with actuator arm stops hoist before fully compressing cylinder.
6. Repeat test several times to ensure proper operation.

**FOLLOW-ON MAINTENANCE:**

None

END OF TASK

This task covers: **Removal and Installation**

INITIAL SETUP

Personnel Required:

67N, UH1 Helicopter Repairer (2)
67T, UH60 Helicopter Repairer (2)
68F, Airmail Electrical Repairer (2)
91W, Medevac Medics

Equipment Condition:

Hoist installed in assembly stand
Control pendant removed

Parts/Materials:

Lockwire (Item 17, App. D)
Cap Plugs (Items 6-9, App. D)

Equipment Condition Para:

Task 2-5
Task 2-16

Tools and Test Equipment:

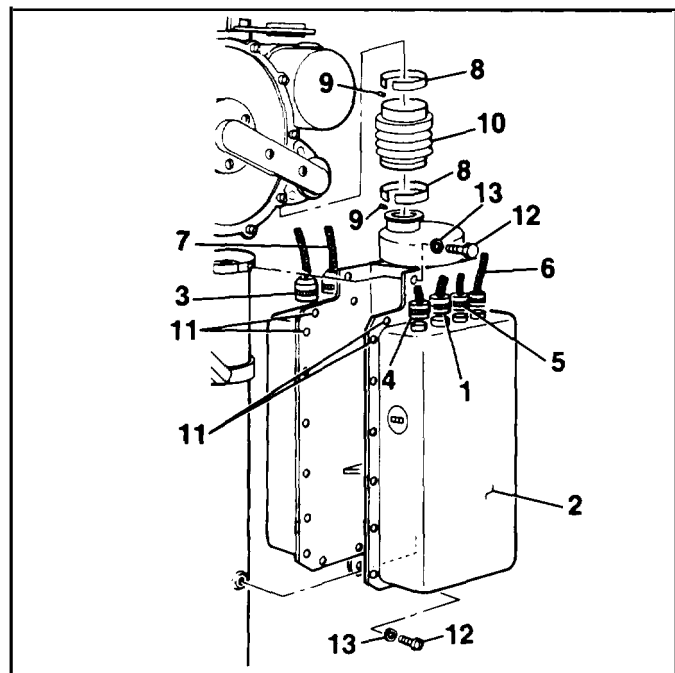
Tool Set, Aviation Unit Maintenance
NSN 4920-00-567-0476
Plier, 44191D192 or equivalent

References:

None

1. Removal.

- a. Remove control pendant cable (1) from control panel assembly (2).
- b. Disconnect electrical connectors (3, 4, 5, 6) from control panel (2). Install protective caps on all receptacles.
- c. Remove lockwire and disconnect electrical connector (7) from control panel (2). Install protective cap.
- d. Using plier, remove bands (8) by removing clips (9). Remove boot (10).
- e. Back off screws (11) until flush with control panel (2).



GO TO NEXT PAGE

2-27. CONTROL PANEL ASSEMBLY - REPLACE (cont)

2-27

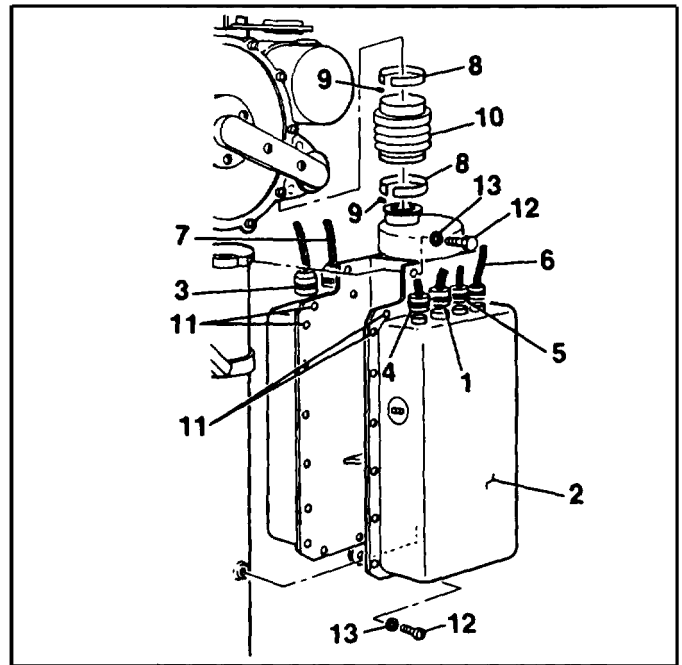
CAUTION

Support weight of control panel assembly during removal to prevent damage to components.

- f. Remove control panel (2) by removing bolts (12) and washers (13).

2. **Installation.**

- a. Position control panel assembly (2) and secure using bolts (12) and washers (13).
- b. Tighten screws (11) on control panel (2).
- c. Connect boot (10) to control panel (2) and winch plenum. Secure using bands (8) and clips (9).
- d. Remove protective caps from receptacles. Connect electrical connectors (3, 4, 5, 6, 7) to control panel (2). Lockwire connector (7).
- e. Install control pendant cable (1).



FOLLOW-ON MAINTENANCE:

Conduct performance check
(Task 2-7)

END OF TASK

This task covers: Inspection

INITIAL SETUP**Personnel Required:**

67N, UH1 Helicopter Repairer
67T, UH60 Helicopter Repairer
91W, Medevac Medics

Equipment Condition:

Hoist installed in helicopter or assembly stand

Parts/Materials:

None

Equipment Condition Para:

Task 2-5

Tools and Test Equipment:

None

References:

None

1. Inspect all parts for nicks, cracks, scratches and dents (refer to Task 2-11).
2. Inspect for corrosion. (Refer to Task 2-11)
3. Inspect identification plate for legibility and security of attachment.
4. Inspect hook and pendant spring for damage.

FOLLOW-ON MAINTENANCE:

Repair boom position support assembly
(Task 2-30)

END OF TASK**2-70 Change 9**

2-29. BOOM POSITION SUPPORT ASSY - ADJUST

2-29

This task covers: Adjustment**INITIAL SETUP****Personnel Required:**

67N, UH1 Helicopter Repairer
 67T, UH60 Helicopter Repairer
 91W, Medevac Medics

Parts/Materials:

Lockwire (Item 17, App. D)
 Locktite Compound (Item 16, App. D)

Tools and Test Equipment:

Tool Kit, Aircraft Mechanic
 NSN 5180-00-323-4692

Equipment Condition:

Hoist installed in helicopter

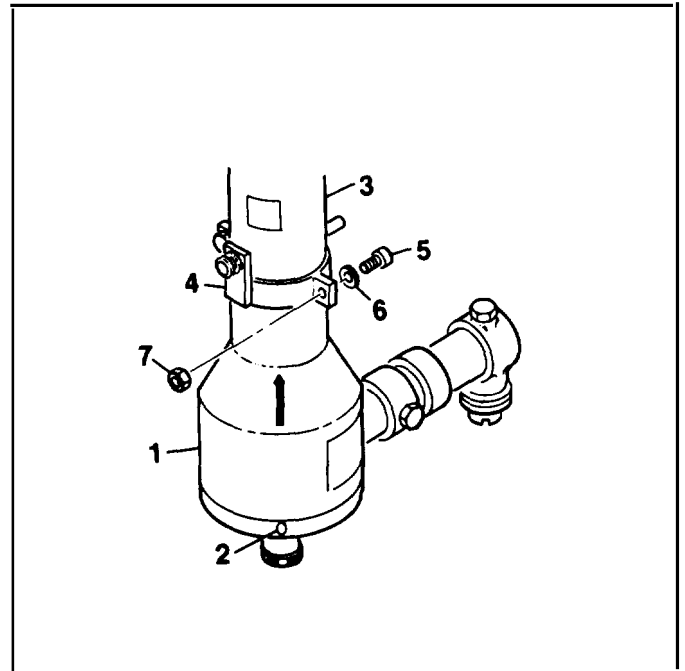
Equipment Condition Para:

Task 2-5

Reference:

None

1. Simulate helicopter floor positions STA 82.05 and BL 35.10 and mark as follows:
 - a. Mark a line 10 inches long out from stud along station line 82.05.
 - b. Mark a line 10 inches long aft from stud along butt line 35.10.
2. Ensure AIRCRAFT POSITION switch is in position 1-3 and boom position actuator is locked in position 1.
3. Release base cover (1) by removing screws (2). Slide cover upon stanchion tube (3) to gain access to boom position switches.
4. Remove stud ring (4) by removing bolts (5), washers (6) and sod nuts (7).
5. Apply electrical power to helicopter and position HOIST PWR switch to ON.

**GO TO NEXT PAGE**

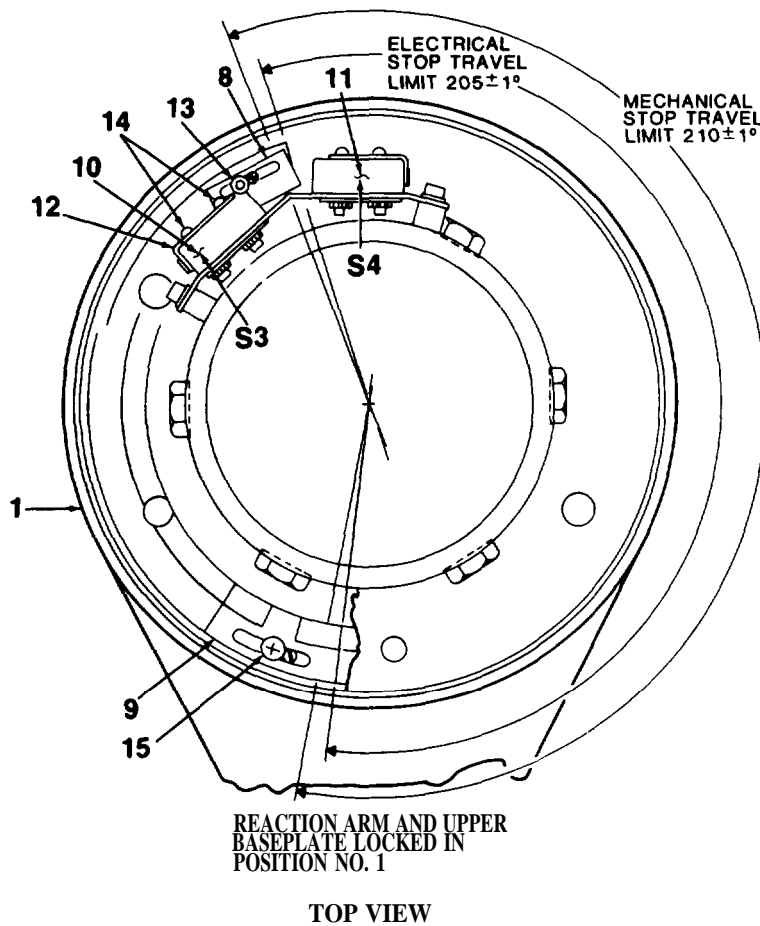
6. Move control pendant BOOM switch to IN, then OUT positions. Note locations of cams (8, 9) at travel extremes.

NOTE

Switches (10, 11) must actuate before hoist mechanical stops engage.

7. With hoist in outboard position (CCW), cam (8) should be under roller leaf actuator (12) of switch (10). Boom head assembly shall be in line with STA 82.05 mark. Adjust switch and cam as follows:

- a. Move HOIST PWR switch to OFF.
- b. Loosen screw (13). Move cam (8) towards switch (11) for over-travel, away from switch for under-trowel.
- c. Apply loctite compound to threads of screw (13). Tighten screw.
- d. Top of cam (8) should depress actuator and just close switch (10).
- e. If further adjustment is required, loosen screws (14) and reposition switch (10). Tighten screws.

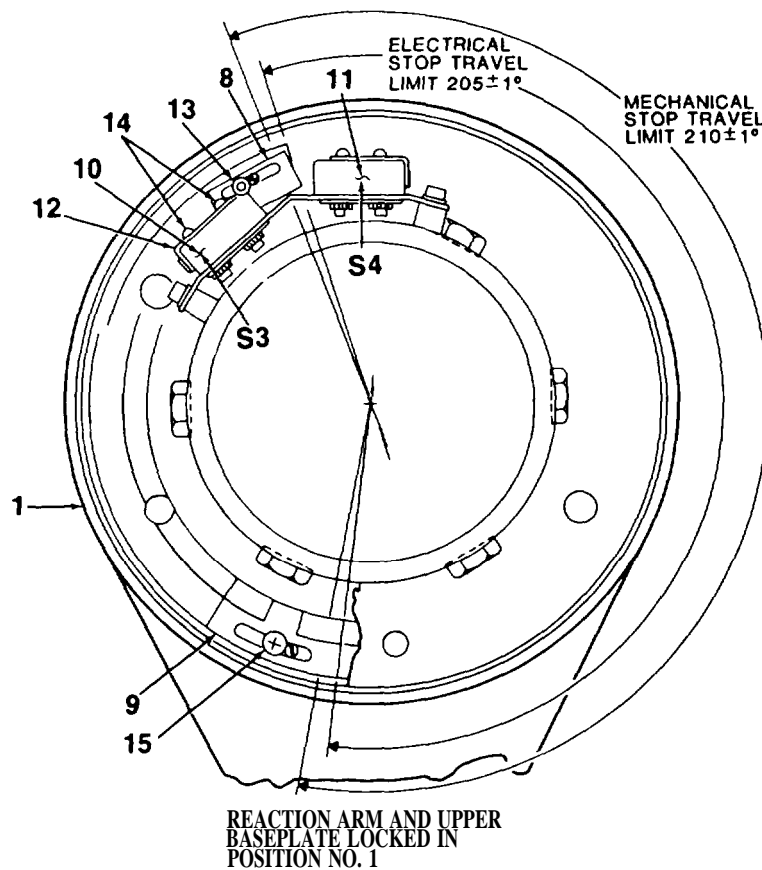


GO TO NEXT PAGE

2-29. BOOM POSITION SUPPORT ASSY - ADJUST (cont)

2-29

- f. Move HOIST PWR switch to ON. Move BOOM switch to IN, then OUT positions.
- g. Check boom travel to ensure proper adjustment of switch (10) and cam (8). Repeat steps a. through e. as required.
8. Move Boom switch to IN position (CW). Cam (9) should be under roller leaf actuator of switch (11). Boom head assembly shall be in line with BL 35.10 mark. Adjust switch and cam as follows:
- Move HOIST PWR switch to OFF.
 - Loosen screw (15). Move cam (9) towards switch (10) for over-travel, away from switch for under-travel
 - Apply locktite compound to threads of screw (15). Tighten screw.
 - Top of cam (9) should depress actuator and just close switch (11).
 - If further adjustment is required, loosen screws (14) and reposition switch (11). Tighten screws.
 - Move HOIST PWR switch to ON. Move BOOM switch to OUT, then IN positions.
 - Check boom travel to ensure proper adjustment of switch (11) and cam (9). Repeat steps a. through e. as required.



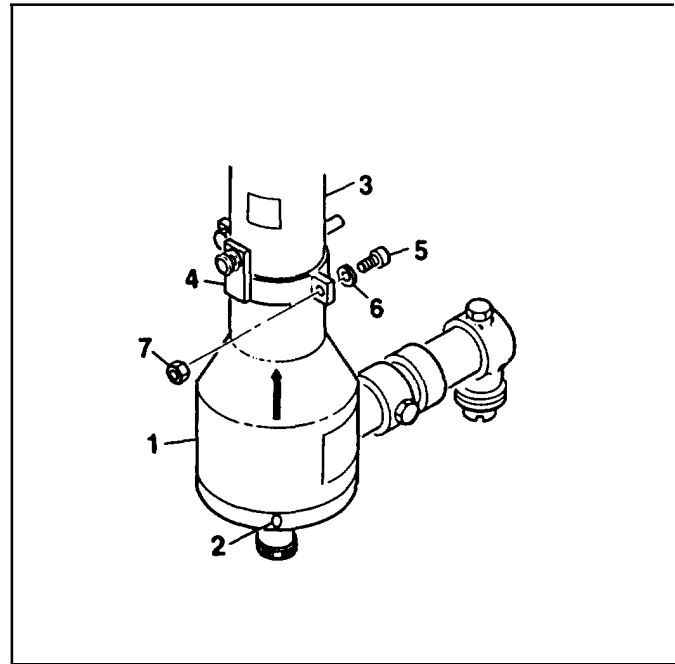
TOP VIEW

GO TO NEXT PAGE

9. Stow hoist and move HOIST PWR switch to OFF. Disconnect electrical power.
10. Slide cover (1) down stanchion tube (3) and position. Secure cover using screws (2). Lock-wire cover.
11. Install stud ring (4) onto stanchion tube (3). Secure using bolts (5), washers (6) and nuts (7).

FOLLOW-ON MAINTENANCE:

None



END OF TASK

2-30. BOOM POSITION SUPPORT ASSY - REPAIR

2-30

This task covers: Disassembly, Cleaning, Inspection, Repair and Reassembly

INITIAL SETUP**Personnel Required:**

67N, UH1 Helicopter Repairer
67T, UH60 Helicopter Repairer
91W, Medevac Medics

Parts/Materials:

Abrasive Cloth, Aluminum Oxide (Item 1,
App. D)
Cleaning Solvent (Item 10, App. D)
Packing, MS28775-133
Trichloroethane (Item 25, App. D)

Tools and Test Equipment:

Tool Set, Aviation Unit Maintenance
NSN 4920-00-567-0476
Tool Kit, Aircraft Mechanic
NSN 5180-00-323-4692
Air Source, 35 psi (241.5 kPa)

Equipment Condition:

Hoist placed on suitable work bench

Equipment Condition Para:

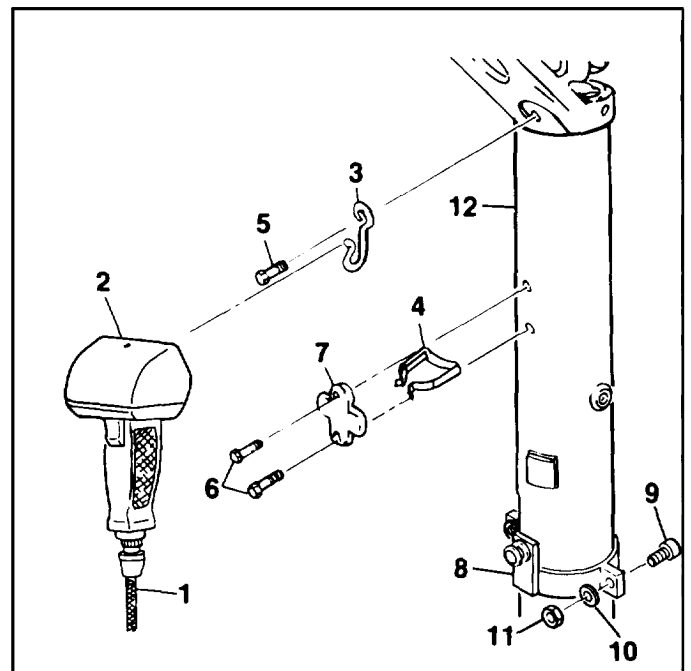
None

References:

None

1. Disassembly.

- a. Disconnect control pendant cable (1) from control pendant (2).
- b. Remove control pendant (2) from hook (3) and pendant spring (4).
- c. Remove hook (3) by removing screw (5).
- d. Remove pendant spring (4) by removing screws (6) and retainer hook (7).
- e. Remove stud ring (8) from stanchion tube (12) by removing bolts (9), washers (10) and nuts (11).



GO TO NEXT PAGE

- f. Remove plunger (13) by removing setscrew (14).
- g. Unscrew height adjuster assembly (15) from upper support assembly (17). Remove and discard packing (16).

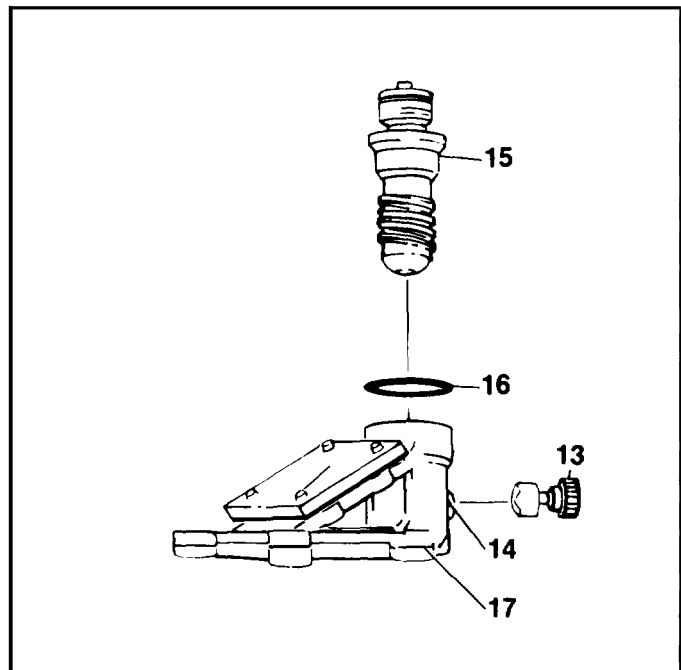
2. Cleaning.

WARNING

Use solvent in a well ventilated area. Avoid prolonged breathing of fume. Keep away from open flame. Use approved safety equipment.

WARNING

Use approved personnel protective equipment (goggles/ face shield) when using compressed air. Air pressure is restricted to a maximum of 35 psi. Do not direct airstream towards self or other personnel as injury may occur.



CAUTION

If parts are not to be inspected immediately after cleaning, dip them in preservative oil to prevent rust spots.

Clean all parts in solvent and rinse thoroughly. Dry with compressed air.

3. Inspection.

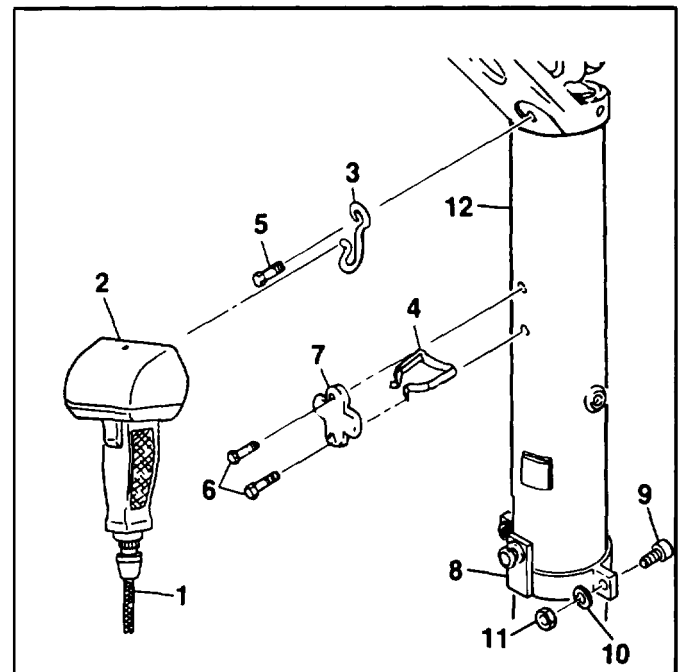
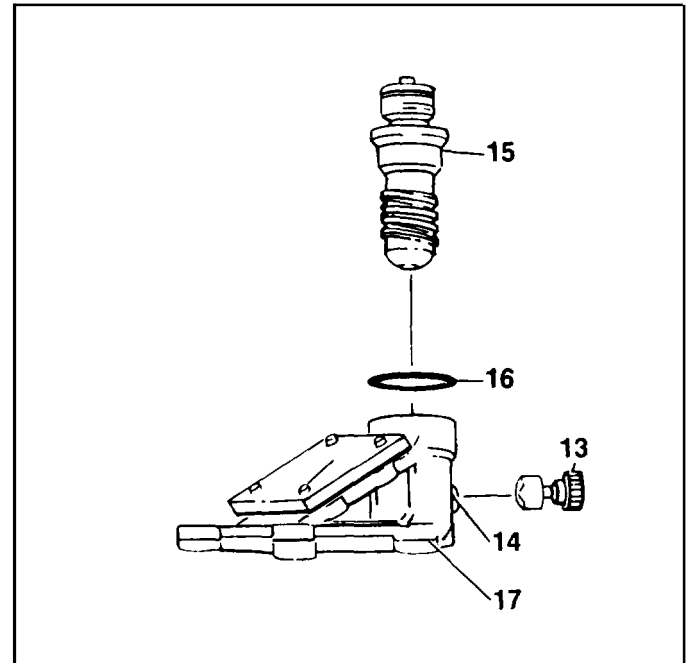
- a. Inspect all parts for nicks, cracks, scratches and dents (refer to Task 2-11).
- b. Inspect for corrosion (refer to Task 2-11).
- c. Inspect all threaded parts for crossed, stripped and damaged threads.
- d. Inspect identification plate for legibility and security of attachment.
- e. Inspect height adjuster assembly (Task 2-32).

GO TO NEXT PAGE

2-30. BOOM POSITION SUPPORT ASSY - REPAIR (cont)

2-30

4. **Repair.** Repair of parts limited to the removal of minor nicks, burrs, scratches or other surface damage using aluminum oxide cloth or fine abrasive. Clean parts thoroughly after repair. If damage is extensive, or if minor repair will affect serviceability, replace the part.
5. **Installation.**
- Lubricate packing (16) and install into upper support assembly (17). Install height adjuster assembly (15).
 - Install plunger (13) and secure using setscrew (14).
 - Install pendant spring (4) using screws (6) and retainer hook (7).
 - Install hook (3) using screw (5).
 - Connect control pendant cable (1) to control pendant (2).
 - Install stud ring (8) onto stanchion tube (12). Secure using bolts (9), washers (10) and nuts (11).

**FOLLOW-ON MAINTENANCE:**

None

END OF TASK

This task covers: Inspection

INITIAL SETUP

Personnel Required:

67N, UH1 Helicopter Repairer
 67T, UH60 Helicopter Repairer
 91W, Medevac Medics

Equipment Condition:

Hoist placed on suitable work bench

Parts/Materials:

None

Equipment Condition Para:

None

Tools and Test Equipment:

None

Reference:

None

1. Inspect height adjuster assembly for nicks, cracks, scratches and dents (refer to Task 2-11).
2. Inspect for corrosion (refer to Task 2-11).
3. Ensure smooth operation free of binding and sticking.

FOLLOW-ON MAINTENANCE:

Repair height adjuster assembly
 (Task 2-32)

END OF TASK

2-32. HEIGHT ADJUSTER ASSEMBLY - REPAIR

2-32

This task covers: Disassembly, Cleaning, Inspection, Repair and Reassembly

INITIAL SETUP**Personnel Required:**

67N, UH1 Helicopter Repairer
67T, UH60 Helicopter Repairer
91W, Medevac Medics

Equipment Condition:

Height adjuster assembly removed

Parts/Materials:

Abrasive Cloth, Aluminum Oxide (Item 1,
App. D)
Cleaning Solvent (Item 10, App. D)

Equipment Condition Para:

Task 2-33

Tools and Test Equipment:

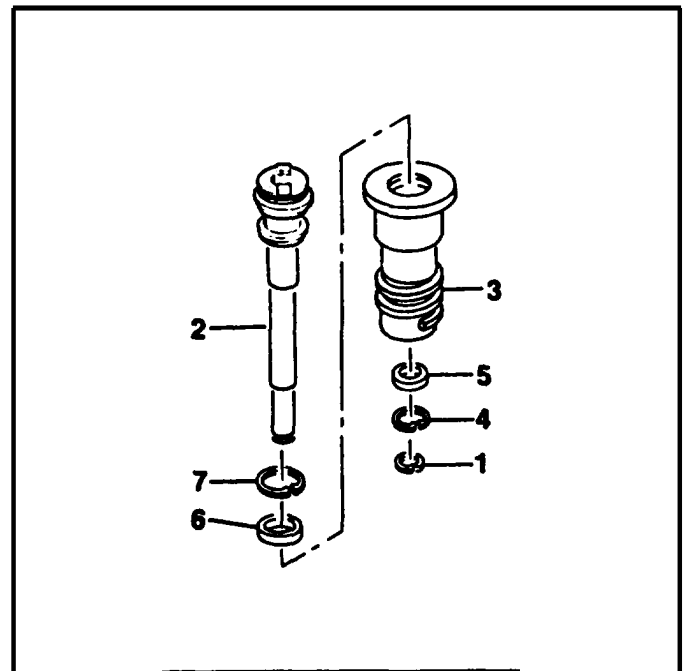
Tool Set, Aviation Unit Maintenance
NSN 4920-00-567-0476
Tool Kit, Aircraft Mechanic
NSN 5180-00-323-4692
Air source, 35 psi

References:

None

1. Disassembly.

- a. Remove retaining ring (1) and remove quick disconnect adapter (2) from shaft (3).
- b. Remove retaining ring (4). Remove bearings (5, 6) and ring (7).



GO TO NEXT PAGE

2. Cleaning.**WARNING**

Use solvent in a well ventilated area. Avoid prolonged breathing of fume. Keep away from open flame. Use approved safety equipment.

WARNING

Use approved personnel protective equipment (goggles/face shield) when using compressed air. Air pressure is restricted to a maximum of 35 psi. Do not direct airstream towards self or other personnel as injury may occur.

CAUTION

If parts are not to be inspected immediately after cleaning, dip them in preservative oil to prevent rust spots.

Clean all parts in solvent and rinse thoroughly. Dry with compressed air.

3. Inspection.

- a. Inspect all parts for nicks, cracks, scratches and dents (refer to Task 2-11).
 - b. Inspect for corrosion (refer to Task 2-11).
 - c. Inspect all threaded parts for crossed, stripped and damaged threads.
 - d. Inspect quick disconnect adapter for damage in accordance with Task 2-34.
 - e. Inspect bearings for cracks and scoring in bearing races. Bearings must rotate smoothly with no noise, binding, or excessive axial or radial play.
4. **Repair.** Repair of parts is limited to the removal of minor nicks, burrs, scratches or other surface damage using aluminum oxide cloth or fine abrasive. Clean parts thoroughly after repair. If damage is extensive, or if minor repair will affect serviceability, replace the part.

GO TO NEXT PAGE

2-32. HEIGHT ADJUSTER ASSEMBLY - REPAIR (cont)

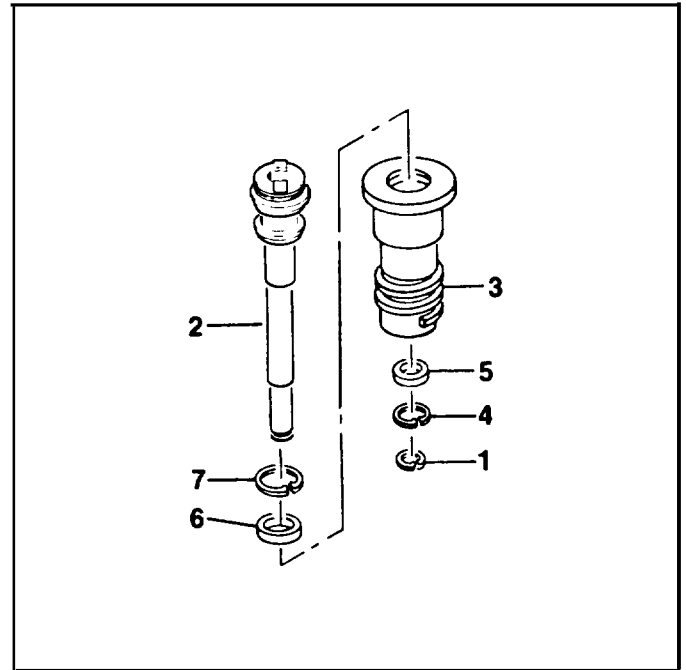
2-32

5. Reassembly.

- a. Install bearing (6) into Shaft (3). Secure using ring (7).
- b. Press bearing (5) into shaft (3) and secure using retaining ring (4).
- c. Install quick disconnect adapter (2) into shaft (3) and secure using retaining ring (1).

FOLLOW-ON MAINTENANCE:

Install height adjuster assembly
Task (2-33)

**END OF TASK**

2-33. HEIGHT ADJUSTER ASSEMBLY - REPLACE

2-33

This task covers: Removal and Installation**INITIAL SETUP****Personnel Required:**

67N, UH1 Helicopter Repairer
 67T, UH60 Helicopter Repairer
 91W, Medevac Medics

Equipment Condition:

Hoist placed on suitable work bench

Parts/Materials:

Petrolatum (Item 19, App. D)
 Packing MS28775-133

Equipment Condition Para:

None

Tools and Test Equipment:

None

References:

None

1. Removal.

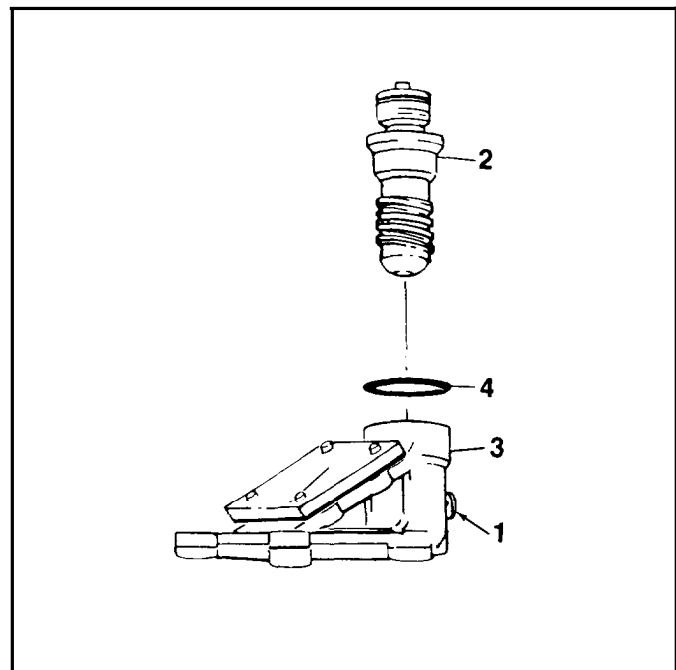
- a. Unlock plunger (1) and unscrew height adjuster assembly (2) from upper support assembly (3).
- b. Remove packing (4).

2. Installation.

- a. Lubricate packing (4) and install into upper support assembly (2).
- b. Screw height adjuster assembly (2) into upper support assembly (3) and secure by locking plunger (1).

FOLLOW-ON MAINTENANCE:

None

**END OF TASK**

2-34. QUICK DISCONNECT (UPPER SUPPORT) - INSPECT

2-34

This task covers: Inspection

INITIAL SETUP**Personnel Required:**

67N, UH1 Helicopter Repairer
67T, UH60 Helicopter Repairer
91W, Medevac Medics

Equipment Condition:

Hoist placed on suitable work bench

Parts/Materials:

None

Equipment Condition Para:

None

Tools and Test Equipment:

None

References:

None

1. Inspect quick disconnect adapter for damage (refer to Task 2-11).
2. Inspect interior surface for crossed, stripped and damaged threads.
3. Inspect for corrosion (refer to Task 2-11).
4. Inspect disconnect tabs for cracks and damage.

FOLLOW-ON MAINTENANCE:

Replace quick disconnect
(Task 2-35)

END OF TASK

This task covers: Removal and Installation

INITIAL SETUP

Personnel Required:

67N, UH1 Helicopter Repairer
 67T, UH60 Helicopter Repairer
 91W, Medevac Medics

Equipment Condition:

Height adjuster assembly removed

Parts/Materials:

None

Equipment Condition Para:

Task 2-33

Tools and Test Equipment:

Tool Set, Aviation Unit Maintenance
 NSN 4920-00-567-0476
 Tool Kit, Aircraft Mechanic
 NSN 5180-00-323-4692

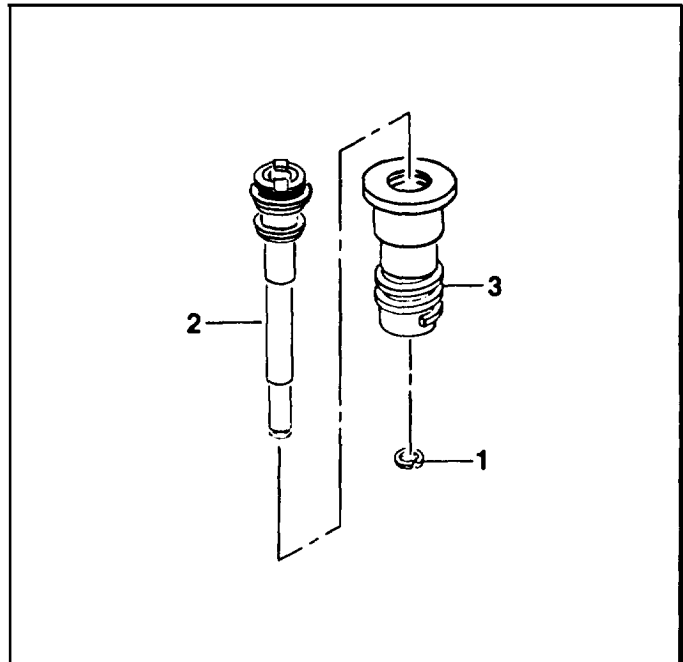
References:

None

1. **Removal.** Remove retaining ring (1) and remove quick disconnect adapter (2) from shaft (3).
2. **Installation.** Install quick disconnect adapter (2) into shaft (3) and secure using retaining ring (1).

FOLLOW-ON MAINTENANCE:

Install height adjuster assembly
 (Task 2-33)



END OF TASK

2-36. UPPER SUPPORT ASSEMBLY - INSPECT

2-36

This task covers: Inspection

INITIAL SETUP**Personnel Required:**

67N, UH1 Helicopter Repairer
67T, UH60 Helicopter Repairer
91W, Medevac Medics

Equipment Condition:

Height adjuster assembly removed

Parts/Materials:

None

Equipment Condition Para:

Task 2-33

Tools and Test Equipment:

None

References:

None

1. Inspect upper support assembly for nicks, cracks, scratches and dents (refer to Task 2-11).
2. Inspect for corrosion (refer to Task 2-11).
3. Inspect interior surface of height adjuster mounting hole for crossed, stripped and damaged threads.

FOLLOW-ON MAINTENANCE:

Repair upper support assembly
(Task 2-37)
Install height adjuster assembly
(Task 2-33)

END OF TASK

2-37. UPPER SUPPORT ASSEMBLY - REPAIR

2-37

This task covers: Repair

INITIAL SETUP

Personnel Required:

67N, UH1 Helicopter Repairer
67T, UH60 Helicopter Repairer
91W, Medevac Medics

Equipment Condition:

Hoist placed on suitable work bench
Height adjuster assembly removed

Parts/Materials:

Abrasive Cloth, Aluminum Oxide (Item 1,
App. D)

Equipment Condition Para:

Task 2-33

Tools and Test Equipment:

None

References:

Painting and Marking of Army Aircraft
TM 55-1500-345-23

Repair of parts is limited to the removal of minor nicks, burrs, scratches or other surface damage using aluminum oxide cloth or fine abrasive. Clean parts thoroughly after repair. If damage is extensive, or if minor repair will affect serviceability, replace the part.

FOLLOW-ON MAINTENANCE:

Install height adjuster assembly
(Task 2-33)

END OF TASK

2-38. LOWER SUPPORT ASSEMBLY - INSPECT

2-38

This task covers: Inspection

INITIAL SETUP**Personnel Required:**

67N, UH1 Helicopter Repairer
67T, UH60 Helicopter Repairer
91W, Medevac Medics

Equipment Condition:

Hoist installed in assembly stand

Parts/Materials:

None

Equipment Condition Para:

Task 2-5

Tools and Test Equipment:

None

Reference:

None

1. Inspect lower support assembly for nicks, cracks, scratches and dents (refer to Task 2-11).
2. Inspect for corrosion (refer to Task 2-11).

FOLLOW-ON MAINTENANCE:

Repair lower support assembly
(Task 2-39)

END OF TASK

This task covers: Repair

INITIAL SETUP

Personnel Required:

67N, UH1 Helicopter Repairer
67T, UH60 Helicopter Repairer
91W, Medevac Medics

Equipment Condition:

Hoist installed in assembly stand

Parts/Materials:

Abrasive Cloth, Aluminum Oxide (Item 1,
App. D)

Equipment Condition Para:

Task 2-5

Tools and Test Equipment:

None

References:

None

Repair of parts is limited to the removal of minor nicks, burrs, scratches or other surface damage using aluminum oxide cloth or fine abrasive. Clean parts thoroughly after repair. If damage is extensive, or if minor repair will affect serviceability, replace the part.

FOLLOW-ON MAINTENANCE:

None

END OF TASK

2-40. REACTION ARM ASSEMBLY - INSPECT

2-40

This task covers: Inspection

INITIAL SETUP**Personnel Required:**

67N, UH1 Helicopter Repairer
67T, UH60 Helicopter Repairer
91W, Medevac Medics

Equipment Condition:

Hoist installed in assembly stand
Reaction arm assembly removed

Parts/Materials:

None

Equipment Condition Para:

Task 2-5
Task 2-41

Tools and Test Equipment:

None

References:

None

1. Inspect reaction arm assembly for nicks, cracks, scratches and dents (refer to Task 2-11).
2. Inspect for corrosion (refer to Task 2-11).
3. Inspect quick disconnect adapter in accordance with Task 2-42.
4. Inspect pin for damage.

FOLLOW-ON MAINTENANCE:

Replace reaction arm assembly
(Task 2-41)

END OF TASK

This task covers: Removal and Installation

INITIAL SETUP**Personnel Required:**

67N, UH1 Helicopter Repairer
67T, UH60 Helicopter Repairer
91W, Medevac Medics

Parts/Materials:

None

Tools and Test Equipment:

None

Equipment Condition:

Hoist placed on suitable work bench

Equipment Condition Para:

None

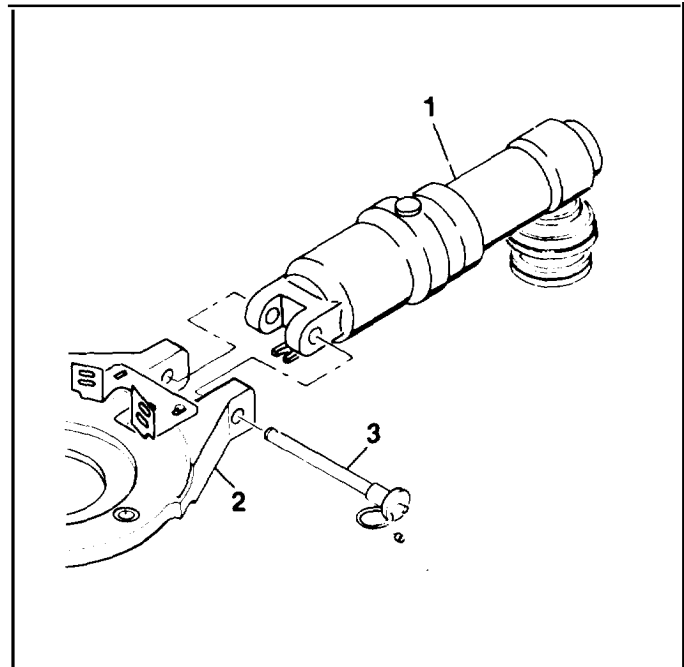
References:

None

1. **Removal.** Remove reaction arm assembly (1) from reaction plate (2) by removing release pin (3).
2. **Installation.** Position reaction arm assembly (1) to reaction plate (2). Secure using quick release pin (3).

FOLLOW-ON MAINTENANCE:

None



END OF TASK

2-42. QUICK DISCONNECT (REACTION ARM) - INSPECT

2-42

This task covers: Inspection**INITIAL SETUP****Personnel Required:**

67N, UH1 Helicopter Repairer
 67T, UH60 Helicopter Repairer
 91W, Medevac Medics

Equipment Condition:

Reaction arm assembly removed

Parts/Materials:

None

Equipment Condition Para:

Task 2-41

Tools and Test Equipment:

None

Reference:

None

-
1. Inspect quick disconnect adapter for damage (refer to Task 2-11).
 2. Inspect interior surface for crossed, stripped and damaged threads.
 3. Inspect for corrosion (refer to Task 2-11).
 4. Inspect disconnect tabs for cracks and damage.

FOLLOW-ON MAINTENANCE:

Replace quick disconnect
 (Task 2-41)

END OF TASK

This task covers: **Removal and Installation**

INITIAL SETUP**Personnel Required:**

67N, UH1 Helicopter Repairer
67T, UH60 Helicopter Repairer
91W, Medevac Medics

Equipment Condition:

Reaction arm assembly removed

Parts/Materials:

None

Equipment Condition Para:

Task 2-41

Tools and Test Equipment:

Tool Set, Aviation Unit Maintenance
NSN 4920-00-567-0476
Tool Kit, Aircraft Mechanic
NSN 5180-00-323-4692

References:

None

1. Removal.

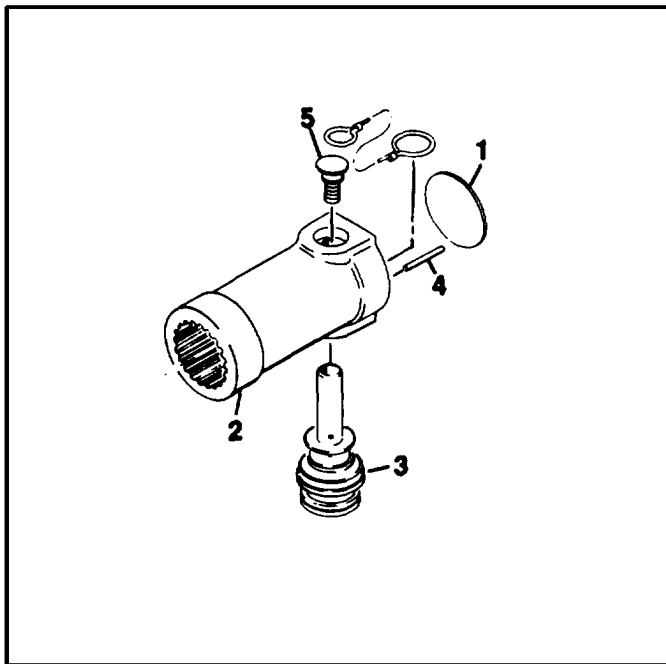
- a. Remove cap (1) from reaction arm (2).
- b. Remove quick disconnect adapter (3) by removing pin (4) and stud (5).

2. Installation.

- a. Position quick disconnect adapter (3) into reaction arm (2) and secure using pin (4) and stud (5).
- b. Install cap (1)

FOLLOW-ON MAINTENANCE:

Install reaction arm assembly
(Task 2-41)

**END OF TASK**

2-44. WINCH ASSEMBLY - INSPECT

2-44

This task covers: Inspection**INITIAL SETUP****Personnel Required:**

67N, UH1 Helicopter Repairer
 67T, UH60 Helicopter Repairer
 91W, Medevac Medics

Equipment Condition:

Hoist installed in helicopter
 or assembly stand

Parts/Materials:

None

Equipment Condition Para:

Task 2-5

Tools and Test Equipment:

None

Reference:

None

-
1. Inspect winch assembly for nicks, cracks, scratches and dents (refer to Task 2-11).
 2. Inspect for corrosion (Task 2-11) and evidence of leakage.
 3. Inspect electrical wiring for frayed and broken insulation. Check for cuts and tears.
 4. Inspect electrical connectors for bent, broken and missing pins. Inspect for evidence of overheating and shorting.
 5. Inspect identification and lubrication plates for legibility and security of attachment.

FOLLOW-ON MAINTENANCE:

Repair winch assembly
 (Task 2-48)

END OF TASK

This task covers: **Draining and Servicing**

INITIAL SETUP

Personnel Required:

67N, UH1 Helicopter Repairer
67T, UH60 Helicopter Repairer
91W, Medevac Medics

Equipment Condition:

Hoist installed in assembly stand

Parts/Materials

Automatic Transmission Fluid (Item 3, App. D)
Lockwire (Item 18, App. D)
Packing, NAS1595-8
Packing, M83248-1-905
Container, Oil Drain

Equipment Condition Para:

Task 2-5

Tools and Test Equipment:

Tool Set, Aviation Unit Maintenance
NSN 4920-00-567-0476
Tool Kit, Aircraft Mechanic
NSN 5180-00-323-4692

Reference:

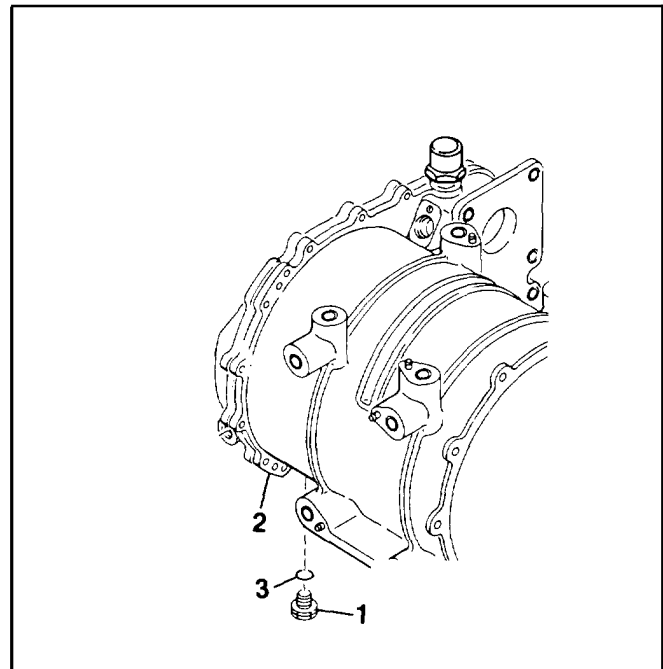
None

1. Draining.

NOTE

Before removing drain plug (1), place a container beneath the winch assembly to catch fluid.

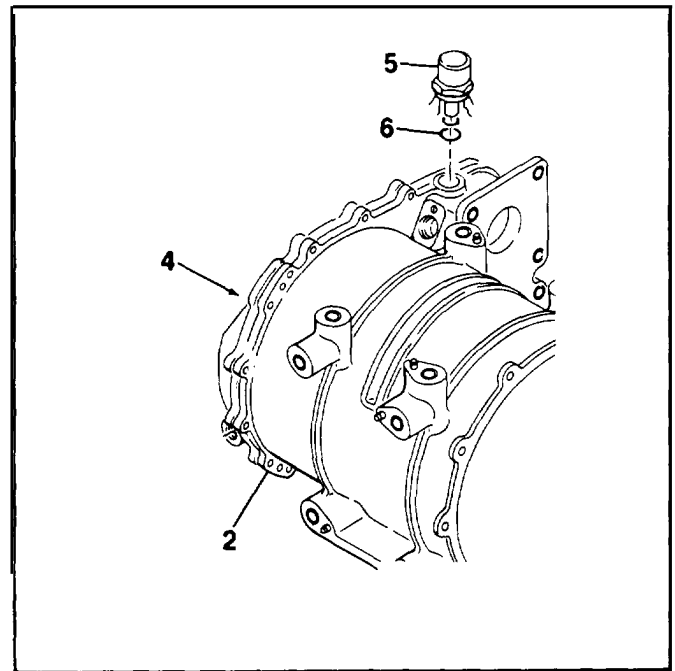
- a. Remove lockwire from drain plug (1) and discard. Remove drain plug from winch housing (2) and allow fluid to drain from winch assembly.
- b. Remove packing (3) from drain plug (1) and discard.
- c. Lubricate new packing (3) and install onto drain plug (1). Install drain plug into winch housing (2) and secure using lockwire.



GO TO NEXT PAGE

2. Servicing.

- a. Check winch assembly fluid level by inspecting sight gage (4). If fluid servicing is required, proceed as follows;
- b. Remove lockwire from breather assembly (5) and discard. Remove breather assembly from winch housing (2).
- c. Remove packing (6) from breather assembly (5) and discard.
- d. Using automatic transmission fluid, service winch assembly until sight gage (4) indicates full level.
- e. Lubricate packing (6) and install onto breather assembly (5). Install breather assembly into winch housing (2) and secure using lockwire.

**FOLLOW-ON MAINTENANCE:**

None

END OF TASK

This task covers: Adjustment

INITIAL SETUP

Personnel Required:

67N, UH1 Helicopter Repairer
67T, UH60 Helicopter Repairer
91W, Medevac Medics

Equipment Condition:

Hoist installed in helicopter
or assembly stand

Parts/Materials:

None

Equipment Condition Para:

Task 2-5

Tools and Test Equipment:

None

References:

None

1. Adjust limit switch drive assembly in accordance with Task 2-54.
2. Adjust automatic brake assembly at AVIM level.

FOLLOW-ON MAINTENANCE:

None

END OF TASK

2-47. WINCH ASSEMBLY - ALIGN

2-47

This task covers: Alignment

INITIAL SETUP**Personnel Required:**

67N, UH1 Helicopter Repairer
67T, UH60 Helicopter Repairer
91W, Medevac Medics

Equipment Condition:

Hoist installed in assembly stand

Parts/Materials

None

Equipment Condition Para:

Task 2-5

Tools and Test Equipment:

None

References:

None

Alignment of the winch assembly consists of aligning the drum assembly in accordance with Task 2-64.

FOLLOW-ON MAINTENANCE:

None

END OF TASK

This task covers: Disassembly, Cleaning, Inspection, Repair and Reassembly

INITIAL SETUP

Personnel Required:

67N, UH1 Helicopter Repairer
 67T, UH60 Helicopter Repairer
 68F, Aircraft Electrical Repairer
 91W, Medevac Medics

Equipment Condition:

Hoist installed on suitable work bench
 Winch assembly drained
 Hoist cable removed

Parts/Materials:

Abrasive Cloth, Aluminum Oxide (Item 1, App. D)
 Automatic Transmission Fluid (Item 3, App. D)
 Cleaning Solvent (Item 10, App. D)
 Lockwire (Item 17, App. D)
 Locktite Compound (Item 16, App. D)
 Packing, NAS1593-134
 Screw (Item 5, App. D)
 Trichloroethane (Item 25, App. D)

Equipment Condition Para:

Task 2-5
 Task 2-45
 Task 2-58

Tools and Test Equipment:

Tool Set, Aviation Unit Maintenance
 NSN 4920-00-567-0476
 Tool Kit, Electrical Repairer
 NSN 5180-00-323-4915
 Air Source, 35 psi

References:

Avionic Cleaning and Corrosion Prevention/Control
 TM 55-1500-343-23
 Aircraft Weapons Systems Cleaning and Corrosion Control
 TM 55-1500-344-23

1. Disassembly.

NOTE

Disassemble only to the extent required to remove and repair defective components.

NOTE

Prior to disassembly, prepare a clean area for receiving parts removed. Attaching hardware shall be loosely reassembled to prevent loss.

GO TO NEXT PAGE

2-48. WINCH ASSEMBLY - REPAIR (cont)

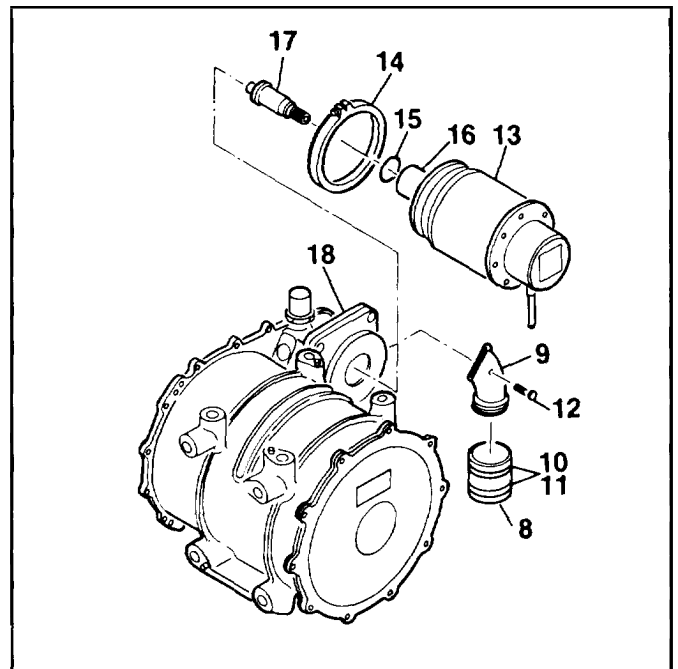
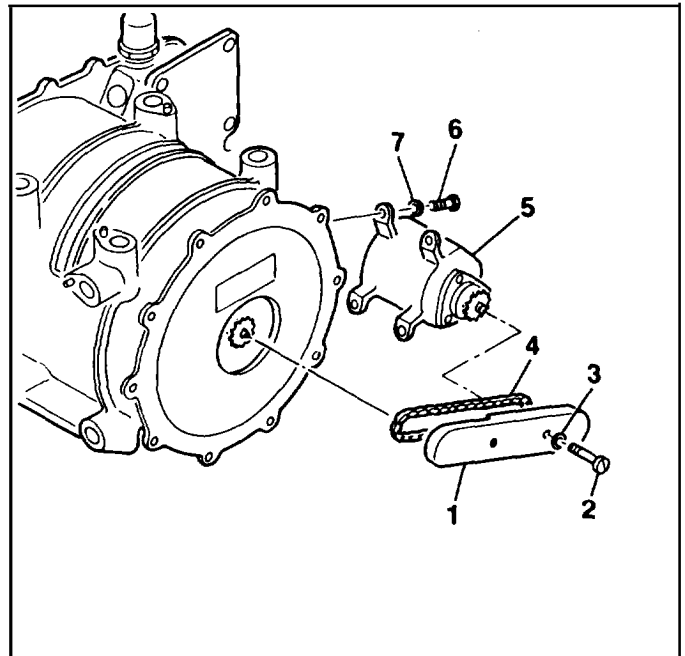
2-48

- a. Remove chain guard cover (1) by removing screws (2) and washers (3).

NOTE

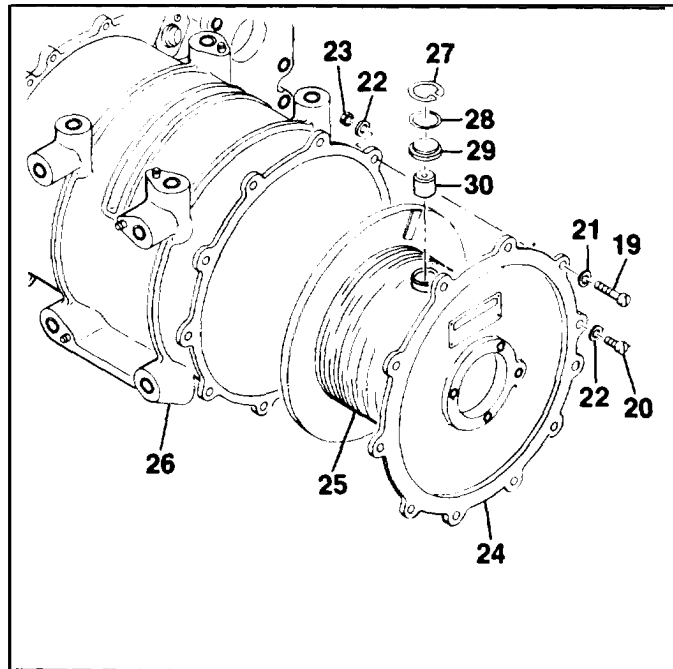
Prior to disconnecting chain (4) from limit switch drive assembly (7), mark sprocket on limit switch and winch assembly to preserve timing and prevent need for adjustment.

- b. Remove chain (4) by removing master link.
- c. Remove limit switch drive assembly (5) by removing screws (6) and washers (7).
- d. Disconnect motor electrical connector from control panel.
- e. Remove boot (8) from motor airduct (9) by removing clips (10) and bands (11). Remove motor airduct by removing bolts (12).
- f. Remove motor (13) by releasing coupling (14).
- g. Remove packing (15) from motor flange (16). Discard packing. Remove inertia dump assembly (17) from adapter plate (18).



GO TO NEXT PAGE

- h Remove screws (19, 20), washers (21, 22) and nuts (23).
- i. Carefully remove assembled cover (24) and drum (25) from winch housing (26).
- j. Remove retaining ring (27) and shim (28). Using a 10-32 screw, remove retainer (29) and level wind shoe (30) from drum (25).
- k. Remove connector (31) by removing screws (32) and clamp (33). Using a suitable pin removal tool, remove pins from connector.
- l Remove heat shrink tubing and braid from switch (34). Unscrew switch from cover (35).
- m. Remove lockwire from drain plug (36). Remove drain plug. Remove and discard packing (37).
- n. Remove lockwire from breather assembly (38). Remove breather assembly. Remove and discard packings (39, 40).



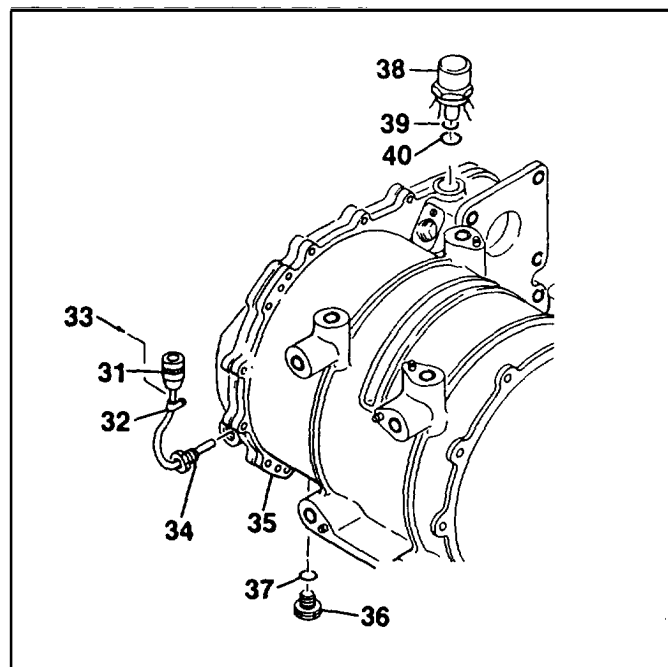
2. Cleaning.

WARNING

Use solvent in a well ventilated area. Avoid prolonged breathing of fume. Keep away from open flame. Use approved safety equipment.

WARNING

Use approved personnel protective equipment (goggles/face shield) when using compressed air, Air pressure is restricted to a maximum of 35 psi. Do not direct airstream towards self or other personnel as injury may occur.



GO TO NEXT PAGE

CAUTION

Do not immerse electrical components in cleaning solvent. Wipe clean with a cloth dampened in soap and water solution.

CAUTION

If parts are not to be inspected immediately after cleaning, dip them in preservative oil to prevent rust spots.

- a. Clean electrical connector contact pins with cloth soaked in trichloroethane.
- b. Wash remaining components in solvent and rinse thoroughly. Dry with compressed air.

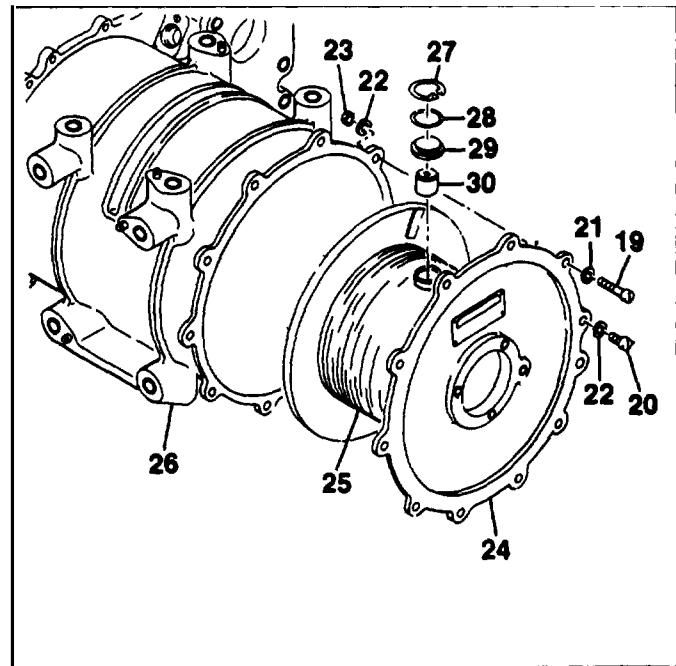
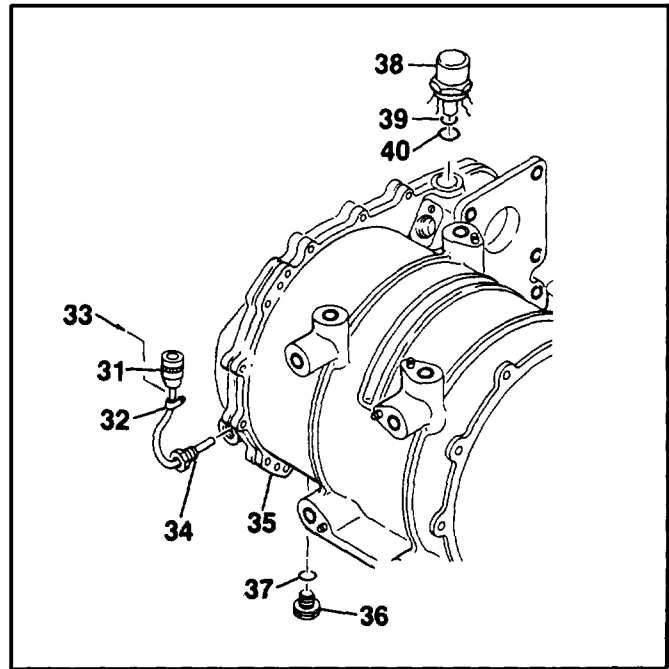
3. Inspection

- a. Inspect all parts for nicks, cracks, scratches and dents (refer to Task 2-11 for inspection criteria).
 - b. Inspect for corrosion and evidence of leakage.
 - c. Inspect all threaded parts for crossed stripped and damaged threads.
 - d. Inspect electrical wiring for frayed and broken insulation. Check for cuts and tears.
 - e. Inspect electrical connectors for bent, broken and missing pins. Inspect for evidence of overheating and shorting.
 - f. Inspect identification and lubrication plates for legibility and security of attachment.
 - g. Inspect limit switch drive assembly and motor assembly for damage. Check for signs of overheating and shorting.
 - h. Inspect cable hook in accordance with Task 2-61.
 - i. Inspect hoist cable in accordance with Task 2-64.
 - j. Inspect boot assembly for cuts, cracks and security of attachment.
4. **Repair.** Repair of parts is limited to the removal of nicks, burrs, scratches or other surface damage using aluminum oxide cloth or fine abrasive. Clean parts thoroughly after repair. If damage is extensive, or if minor repair will affect serviceability, replace the part.

GO TO NEXT PAGE

5. Reassembly.

- a. Lubricate packing (37) and install. Install drain plug (37) and secure using lockwire.
- b. Lubricate packings (39, 40) and install onto breather assembly (38). Install breather assembly onto winch housing and secure using lockwire.
- c. Screw thermal switch (34) into winch housing. Install heat shrink tubing and electrical braiding.
- d. Using a suitable pin installation tool, install pins into connector (31). Secure electrical braid and heat shrink tubing in place.
- e. Install connector plug (31) and secure using clamp (32) and screws (33).
- f. Using a 10-32 screw, install level wind shoe (30) and retainer (29). **Add shims (28) to obtain end play of .004 to .008 in.** between shoe and retainer. Install retaining ring (27) into drum assembly. Align matched curved surfaces.
- g. Position drum assembly (25) near flush with drum cover assembly (24) by rotating drum in relation to cover.
- h. Lower assembled drum (25) and cover (24) into winch housing (26). Ensure proper alignment of drum shaft and drum drive gear splines.
- i. Align cover (24) to housing (26) to enable installation of limit switch drive assembly (7). Install screws (19, 20), washers (21, 22) and nuts (23). **Torque screws to 12-15 in.lbs**



GO TO NEXT PAGE

2-48. WINCH ASSEMBLY - REPAIR (cont)

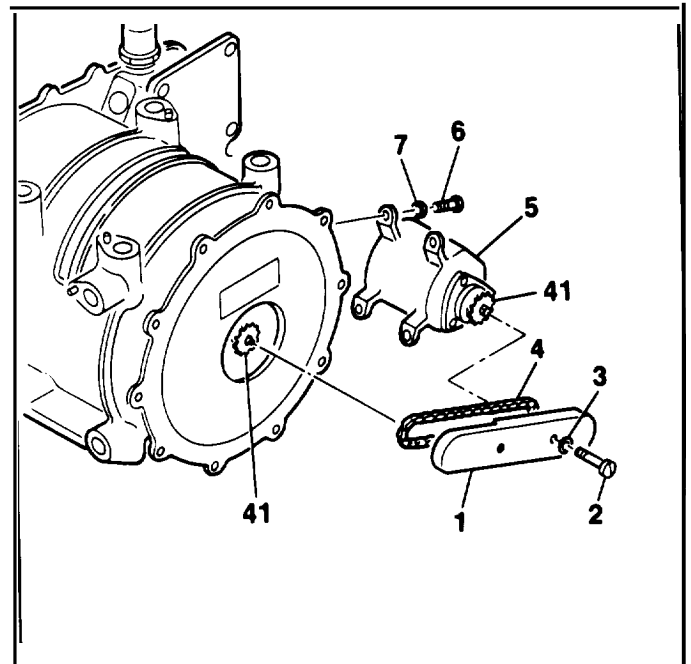
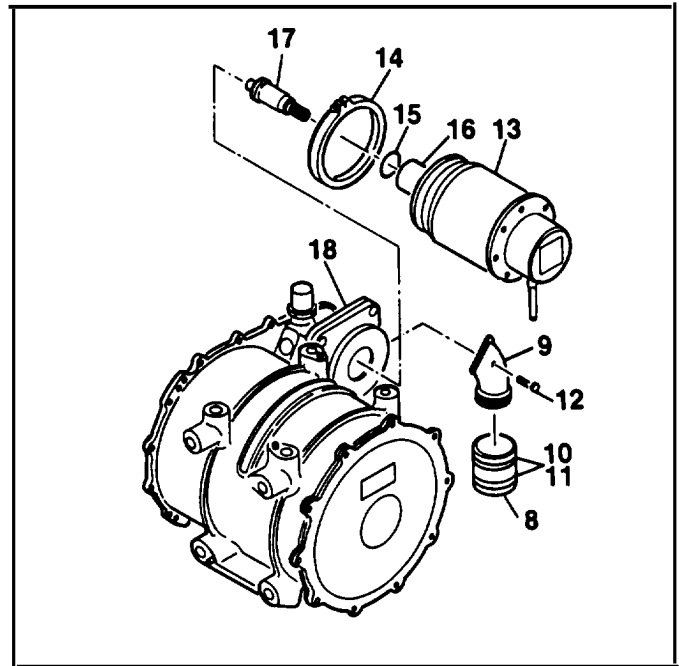
2-48

- i Lubricate packing (15) and install onto motor flange (16). Install inertia dump assembly (17).
- k. Install coupling (14) onto motor mount adapter plate (18). Align pin on adapter plate with hole on motor end bell.
- l. Install motor (13) onto adapter plate (18), ensuring splined end of motor meshes with inertia dump assembly (17). Secure by tightening coupling (14).
- m Install motor abduct (9) using bolts (12). Attach boot (18) using bands (10) and clips (11).
- n. Install limit switch drive assembly (5) using screws (6) and washers (7). **Torque screws to 12-15 in.lbs.**

NOTE

Limit switch drive screws (6) may be loosened to assist in the installation of roller chain (4). Tighten screws (6) after installation.

- o. Position unconnected roller chain (4) onto sprockets (41). Connect chain by installing master link.
- p. Apply locktite compound to threads of screws (2). Install chain guard cover (1) using screws and washers (3). **Torque screws to 12-15 in.lbs.**

**GO TO NEXT PAGE**

FOLLOW-ON MAINTENANCE:

Install hoist cable

(Task 2-60)

Service winch assembly

(Task 2-45)

Adjust limit switch drive assembly

(Task 2-54)

Align drum assembly

(Task 2-64)

conduct performance check

(Task 2-7)

END OF TASK

2-49. ELECTRIC MOTOR - INSPECT

2-49

This task covers: Inspection**INITIAL SETUP****Personnel Required:**

67N, UH1 Helicopter Repairer
 67T, UH60 Helicopter Repairer
 91W, Medevac Medics

Parts/Materials:

None

Tools and Test Equipment:

None

Equipment Condition:

Hoist installed in helicopter or assembly stand.
 Electric motor removed.

Equipment Condition para:

Task 2-5
 Task 2-50

References:

None

-
1. Inspect electric motor for nicks, cracks, scratches and dents (refer to Task 2-11).
 2. Inspect for corrosion (refer to Task 2-11).
 3. Inspect electrical wiring for frayed and broken insulation. Check for cuts and tears.
 4. Inspect electrical connector for bent, broken and missing pins.
 5. Inspect for evidence of overheating and shorting.
 6. Inspect spline for nicks, burrs, galling, pitting and uneven wear. Check for chipped and cracked spline teeth.
 7. Inspect identification plate for legibility and security of attachment.

FOLLOW-ON MAINTENANCE:

Replace electric motor
 (Task 2-50)

END OF TASK

This task covers: Removal and Installation

INITIAL SETUP

Personnel Required:

67N, UH1 Helicopter Repairer
 67T, UH60 Helicopter Repairer
 91W, Medevac Medics

Equipment Condition:

Hoist installed in assembly stand

Parts/Materials:

Automatic Transmission Fluid (Item 3,
 App. D)
 Packing, NAS1593-133

Equipment Condition Para:

Task 2-5

Tools and Test Equipment:

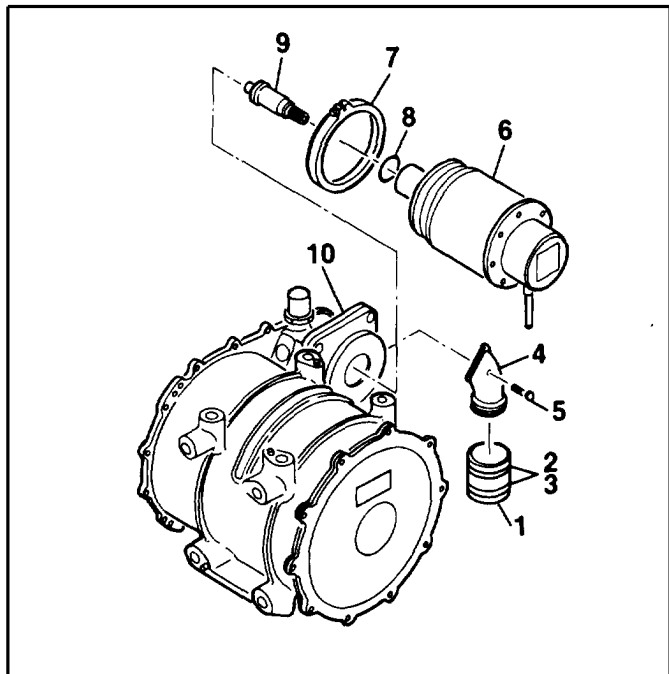
Tool Kit, Aircraft Mechanic
 NSN 5180-00-323-4692

References:

None

1. Removal.

- a. Remove boot (1) by removing clips (2) and bands (3).
- b. Remove motor airduct (4) by removing bolt (5).
- c. Remove motor (6) by releasing coupling (7).
- d. Remove packing (8) from motor (6). Discard packing. Remove inertia dump assembly (9) from adapter plate (10).



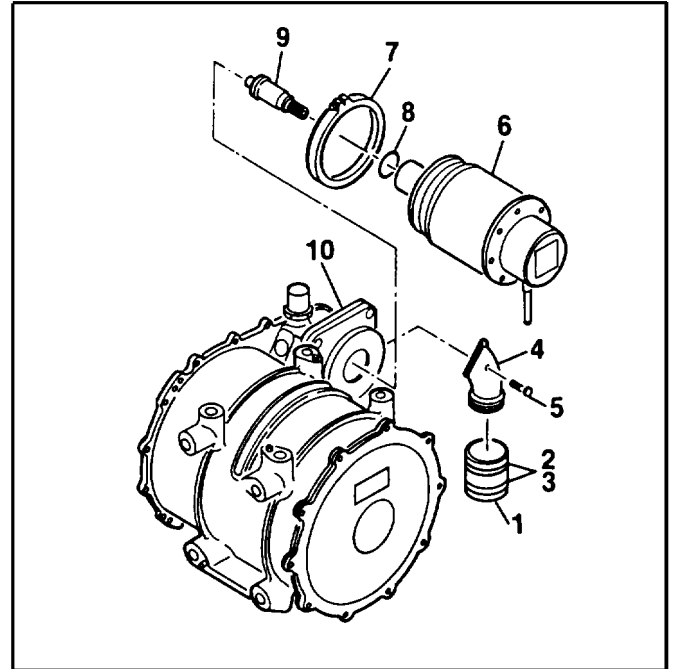
GO TO NEXT PAGE

2-50. ELECTRIC MOTOR - REPLACE (cont)

2-50

2. Installation.

- a. Lubricate packing (8) and install onto motor (6). Align inertia dump assembly (9) and install into adapter plate (10).
- b. Install coupling (7) onto adapter plate (10). Align pin on adapter plate with hole on motor end bell.
- c. Install motor (6) onto adapter plate (10), ensuring splined end of motor meshes with inertia dump assembly (9). Secure by tightening coupling (7).
- d. Install motor airduct (4) using bolt (5). Install boot (1) using clips (2) and bands (3).

**FOLLOW-ON MAINTENANCE**

Conduct performance check
(Task 2-7)

END OF TASK

This task covers: Inspection

INITIAL SETUP

Personnel Required:

67N, UH1 Helicopter Repairer
67T, UH60 Helicopter Repairer
91W, Medevac Medics

Equipment Condition:

Hoist installed in assembly stand
Inertia dump assembly removed

Parts/Materials:

None

Equipment Condition Para:

Task 2-5
Task 2-52

Tools and Test Equipment:

None

References:

None

1. Inspect inertia dump assembly for nicks, cracks, scratches and gouges (refer to Task 2-11).
2. Inspect for corrosion (refer to Task 2-11).
3. Inspect spline for nicks, burrs, galling, pitting and uneven wear (refer to Task 2-11). Check for chipped or cracked spline teeth.

FOLLOW-ON MAINTENANCE:

Replace inertia dump assembly
(Task 2-52)

END OF TASK

2-52. INERTIA DUMP ASSEMBLY - REPLACE

2-52

This task covers: Removal and Installation**INITIAL SETUP****Personnel Required:**

67N, UH1 Helicopter Repairer
 67T, UH60 Helicopter Repairer
 91W, Medevac Medics

Parts/Materials:

Automatic Transmission Fluid, (Item 3,
 App. D)
 Packing, NAS1593-133

Tools and Test Equipment:

Tool Set, Aviation Unit Maintenance
 NSN 4920-00-567-0476
 Tool Kit, Aircraft Mechanic
 NSN 5180-00-323-4692

Equipment Condition:

Hoist installed in assembly stand

Equipment Condition Para:

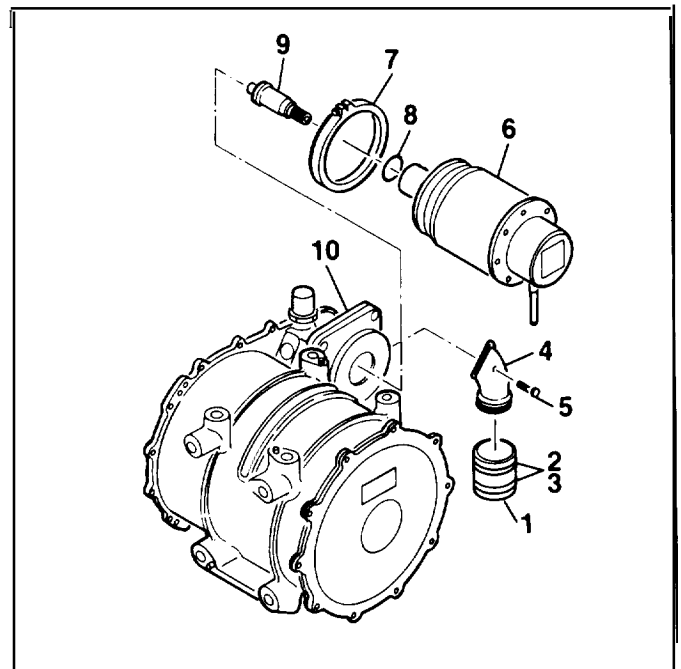
Task 2-5

Reference:

None

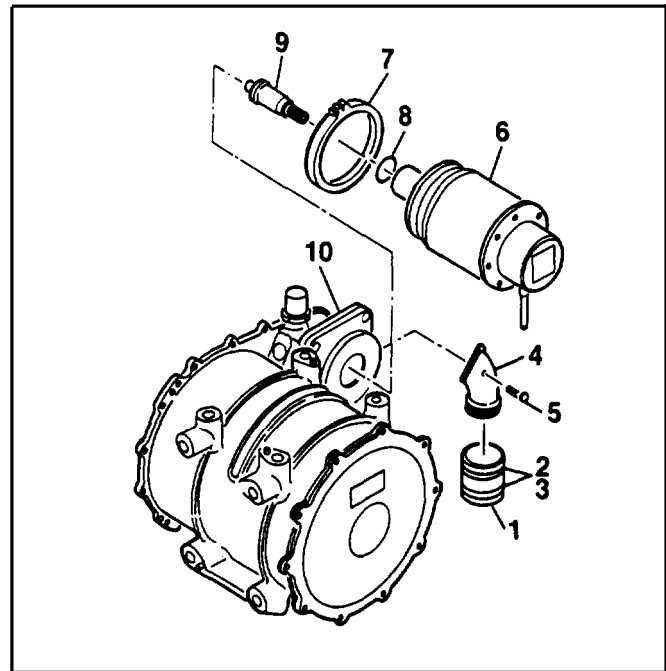
1. Removal.

- a. Remove boot (1) by removing clips (2) and bands (3).
- b. Remove motor airduct (4) by removing bolt (5).
- c. Remove motor (6) by releasing coupling (7).
- d. Remove packing (8) from motor (6). Discard packing. Remove inertia dump assembly (9) from adapter plate (10).

**GO TO NEXT PAGE**

2. Installation.

- a. Lubricate packing (8) and install onto motor (6). Align inertia dump assembly (9) and install into adapter plate (10).
- b. Install coupling (7) onto adapter plate (10). Align pin on adapter plate with hole on motor end bell.
- c. Install motor (6) onto adapter plate (10), ensuring splined end of motor meshes with inertia dump assembly (9). Secure by tightening coupling (7).
- d. Install motor abduct (4) using bolt (5). Install boot (1) using clips (2) and bands (3).

**FOLLOW-ON MAINTENANCE**

conduct performance check
(Task 2-7)

END OF TASK

2-53. LIMIT SWITCH DRIVE ASSEMBLY - INSPECT

2-53

This task covers: Inspection**INITIAL SETUP****Personnel Required:**

67N, UH1 Helicopter Repairer
 67T, UH60 Helicopter Repairer
 91W, Medevac Medics

Equipment Condition:

Hoist installed in assembly stand

Parts/Materials:

None

Equipment Condition Para:

Task 2-5

Tools and Test Equipment:

None

References:

None

-
1. Inspect limit switch for nicks, cracks, scratches and dents (refer to Task 2-11).
 2. Inspect for corrosion (refer to Task 2-11).
 3. Inspect electrical wiring for frayed and broken insulation. Check for cuts and tears.
 4. Inspect electrical connector for bent, broken and missing pins.
 5. Inspect for evidence of overheating and shorting.
 6. Inspect sprocket for nicks, burrs, galling, pitting and uneven wear (refer to Task 2-11). Check for chipped and cracked spline teeth.
 7. Inspect identification plate for legibility and security of attachment.
 8. Inspect cams for excessive play and wear.

FOLLOW-ON MAINTENANCE:

None

END OF TASK

This task covers: Adjustment

INITIAL SETUP

Personnel Required:

67N, UH1 Helicopter Repairer
 67T, UH60 Helicopter Repairer
 91W, Medevac Medics

Equipment Condition:

Hoist installed in assembly stand

Parts/Materials:

None

Equipment Condition Para:

Task 2-5

Tools and Test Equipment:

Tool Set, Aviation Unit Maintenance
 NSN 4920-00-567-0476
 Tool Kit, Aircraft Mechanic
 NSN 5180-00-323-4692
 Cable spool, 42277-730 or
 equivalent
 Ground Power Unit (GPU)

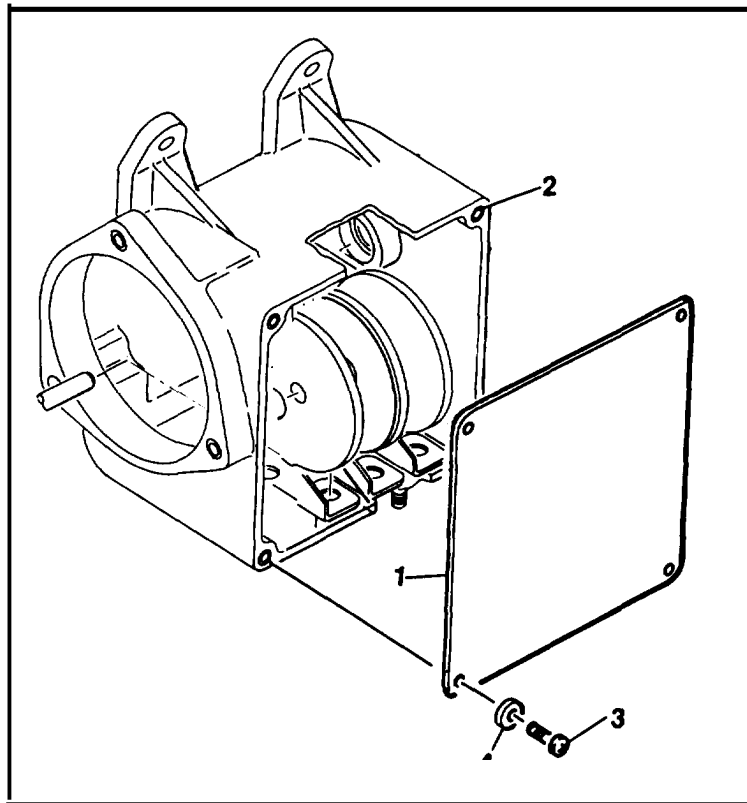
References:

None

1. Remove instruction plate (1) from limit switch drive assembly (2) by removing screws (3) and washers (4).
2. Apply 28 vdc to hoist.

CAUTION

Protect hoist cable from damage. Do not allow kinks or bends to occur. Maintain hook weight on cable at all times. Feed onto cable spool or a suitable container.

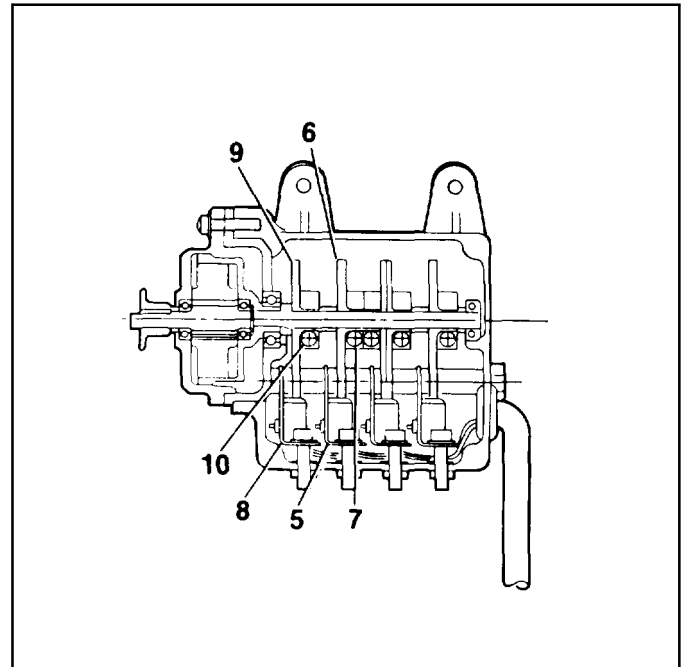


GO TO NEXT PAGE

CAUTION

Switch adjusting screws are factory set.
Do not adjust. Adjusting screws will
result in component failure.

3. Move control pendant CABLE UP/DOWN switch to DWN. Reel out cable until SW2 DOWN LIMIT switch (5) stops operation.
4. Loosen SW2 switch cam (6) by loosening cam screw (7).
5. Slowly reel out cable until SW1 DOWN ALL STOP switch (8) actuates.
6. Three wraps of cable shall remain on hoist drum. Reel on or off cable until three wraps are obtained. Hold drum.
7. Loosen SW1 switch cam (9) by loosening cam screw (10). Adjust cam until cam just actuates switch. Tighten screw.
8. Reel cable onto drum, then reel off to check adjustment of switch SW1 (8). Repeat steps 6 and 7 until adjustment is correct.
9. Slowly move control pendant switch to UP. Reel in cable until five wraps are visible on drum. Ensure cable sets properly into drum grooves
10. Adjust SW2 switch cam (6) until cam just actuates switch (5). Tighten screw (7).



GO TO NEXT PAGE

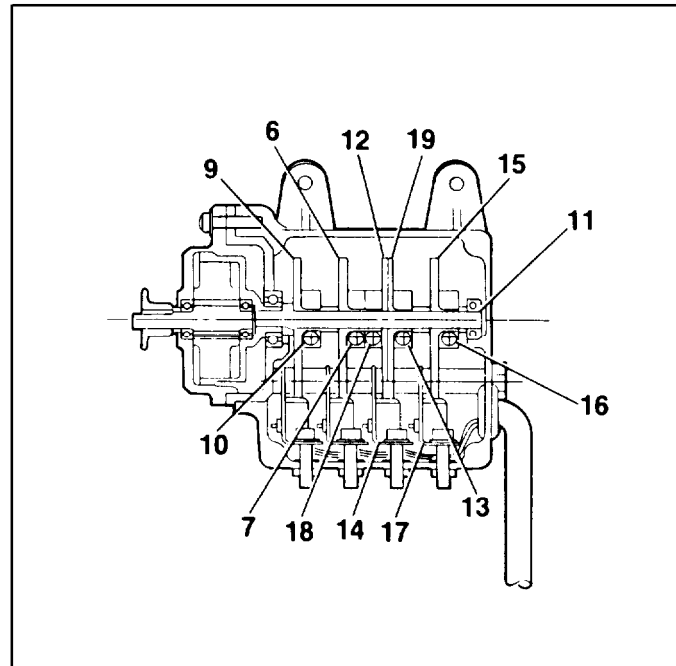
11. Ensure SW1 and SW2 cam screws (7, 10) are tight preventing cams (6, 9) from rotating on shaft (11).

NOTE

The SW3 caution light switch illuminates the CAUTION lights and limits maximum hoist speed to 67 feet per minute.

NOTE

The yellow CAUTION lights are illuminated from the time the hoist power switch is turned until the hoist cable is extended beyond 10 feet.



12. Move control pendant switch to DOWN. Reel out hoist cable until 240 feet of cable is extended. Yellow CAUTION lights shall illuminate.
13. If yellow CAUTION lights fail to illuminate, proceed as follows:
- Loosen SW3 switch cam (12) by loosening screw (18).
 - Adjust cam (12) until cam just actuates SW3 switch (14). Tighten screw (18).
14. Move control pendant switch to UP. Reel in hoist cable until cable hook is within 10 feet of full stow. Yellow CAUTION lights shall illuminate.
15. If yellow CAUTION lights fail to illuminate, proceed as follows:
- Loosen SW3 switch cam (19) by loosening screw (13).
 - Adjust cam (19) until cam just actuates SW3 switch (14). Tighten screw (13).
16. Reel cable out, then in to check adjustment of switch SW3 (14), Ensure illumination of CAUTION lights. Repeat steps 12 through 15 until adjustment is correct.
17. Install hook assembly if removed (Task 2-58). Slowly move control pendant switch to UP. Reel in hoist cable until cable hook is within one foot of up-limit actuator assembly.
18. Loosen SW4 switch can (15) by loosening screw (16).
19. Adjust cam (15) until cam just actuates SW4 switch (17). Tighten screw (16).

GO TO NEXT PAGE

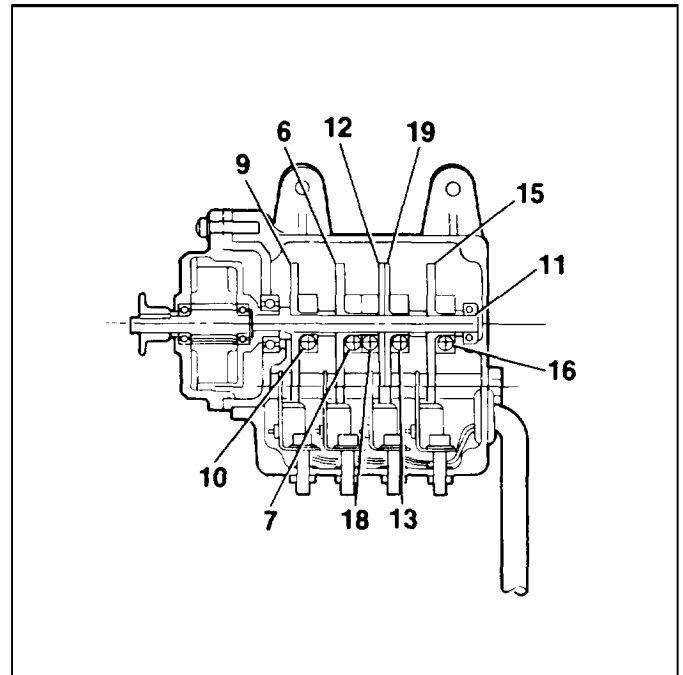
2-54. LIMIT SWITCH DRIVE ASSEMBLY - ADJUST (cont)

2-54

20. Reel cable out to 15-20 feet. Move control pendant switch to FAST UP and reel in hoist cable until cable hook is within one foot of full stow.
21. Hoist speed shall reduce to 12 feet per minute maximum. Repeat steps 18 and 19 until adjustment is correct.
22. Ensure five cam screws (7, 10, 13, 16, 18) are tight, preventing cams (6, 9, 12, 15, 19) from rotating on shaft (11).
23. Install instruction plate using screws and washers.

FOLLOW-ON MAINTENANCE:

Conduct performance check
(Task 2-7)

**END OF TASK**

This task covers: Removal and Installation

INITIAL SETUP

Personnel Required:

67N, UH1 Helicopter Repairer
67T, UH60 Helicopter Repairer
91W, Medevac Medics

Equipment Condition:

Hoist installed in assembly stand

Parts/Materials:

Locktite Compound (Item 16, App. D)

Equipment Condition Para:

Task 2-5

Tools and Test Equipment:

Tool Set, Aviation Unit Maintenance
NSN 4920-00-567-0476
Tool Kit, Aircraft Mechanic
NSN 5180-00-323-4692

References:

None

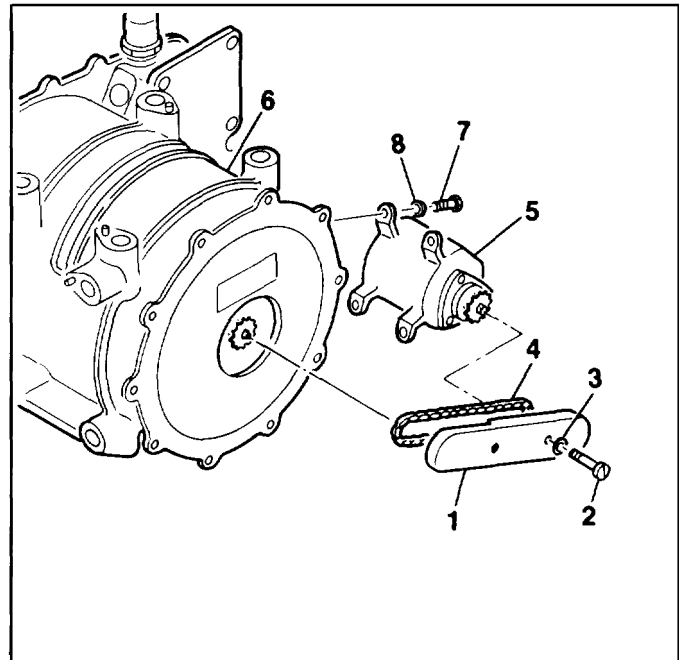
1. Removal.

- a. Remove chain guard cover (1) by removing Screws (2) and washers (3).

NOTE

Prior to disconnecting chain (4) from limit switch drive assembly (5), tape sprocket of drive assembly to assembly housing to preserve timing and prevent need for adjustment.

- b. Remove chain (4) by removing master link.
- c. Remove limit switch drive assembly (5) from winch housing (6) by removing screws (7) and washers (8).



GO TO NEXT PAGE

2-55. LIMIT SWITCH DRIVE ASSEMBLY - REPLACE (cont)

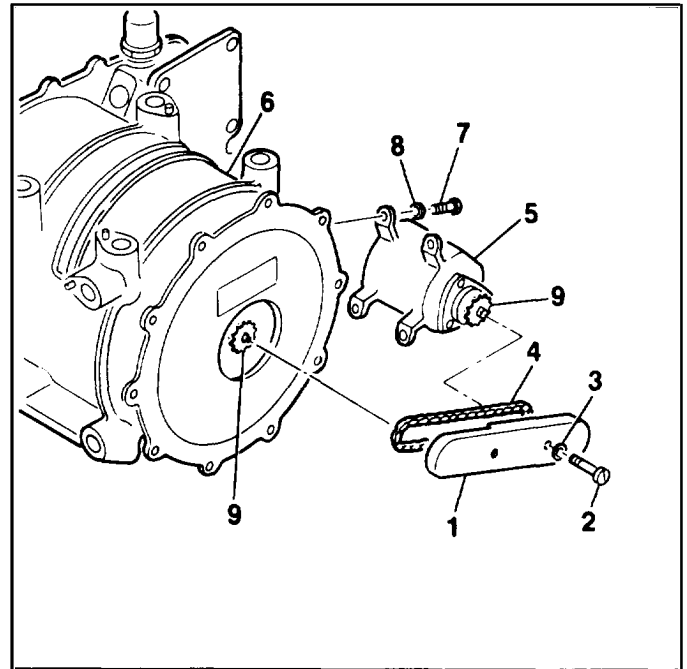
2-55

2. Installation.

- a. Install limit switch drive assembly (5) to winch housing (6) using screws (7) and washers (8). **Torque screws to 12-15 in.lbs.**
- b. Position unconnected chain (4) onto sprockets (9). Connect chain by installing master link.
- c. Apply adhesive to threads of screws (2). Install chain guard cover (1) using screws and washers (3). **Torque screws to 12-15 in.lbs.**

FOLLOW-ON MAINTENANCE:

Adjust limit switch drive assembly (Task 2-54)

**END OF TASK**

2-56. CABLE HOOK ASSEMBLY - INSPECT

2-56

This task covers: Inspection

INITIAL SETUP

Personnel Required:

67N, UH1 Helicopter Repairer
 67T, UH60 Helicopter Repairer
 91W, Medevac Medics

Parts/Materials:

None

Tools and Test Equipment:

None

Equipment Condition:

Hoist installed in helicopter or assembly stand

Equipment Condition:

Task 2-5

References:

None

1. Inspect cable hook assembly for nicks, cracks, swatches and dents (refer to Task 2-11).
2. Inspect for corrosion (refer to Task 2-11).
3. Depress cable hook keeper to ensure smooth operation, free of binding or sticking.
4. Ensure cable hook is securely attached to hoist cable.
5. Ensure cable hook rotates 360 degrees freely.

FOLLOW-ON MAINTENANCE:

Repair cable hook assembly
 (Task 2-58)

END OF TASK

**THIS PAGE
INTENTIONALLY
LEFT BLANK**

This task covers: **Disassembly, Cleaning, Inspection, Repair and Reassembly**

INITIAL SETUP**Personnel Required:**

67N, UH1 Helicopter Repairer
67T, UH60 Helicopter Repairer
68G, Airframe Repairer
91W, Medevac Medics

Equipment Condition:

Cable hook assembly removed

Parts/Materials:

Abrasive Cloth, Aluminum Oxide (Item 1,
App. D)
Petrolatum (Item 19, App. D)
Rivet MS20613-4C20

Equipment Condition Para:

Task 2-58

Tools and Test Equipment:

Tool Set, Aviation Unit Maintenance
NSN 4920-00-567-0476
Tool Kit, Aircraft Mechanic
NSN 5180-00-323-4692
Air source, 35 psi

References:

None

1. Disassembly.

- a. Pry striker disk (1) and carrier assembly (2) from cylinder (3).
- b. Remove lockspring (4), retainers (5), bearing (6), bearing retainer (7) from hook assembly (8).
- c. Remove cable hook keeper (9), release pin (10), bushing (11) and torsion spring (12) by removing rivet (13), Discard rivet.

GO TO NEXT PAGE

2. Cleaning.**WARNING**

Use solvent in a well ventilated area. Avoid prolonged breathing of fume. Keep away from open flame. Use approved safety equipment.

WARNING

Use approved personnel protective equipment (goggles / face shield) when using compressed air. Air pressure is restricted to a maximum of 35 psi. Do not direct airstream towards self or other personnel as injury may occur.

CAUTION

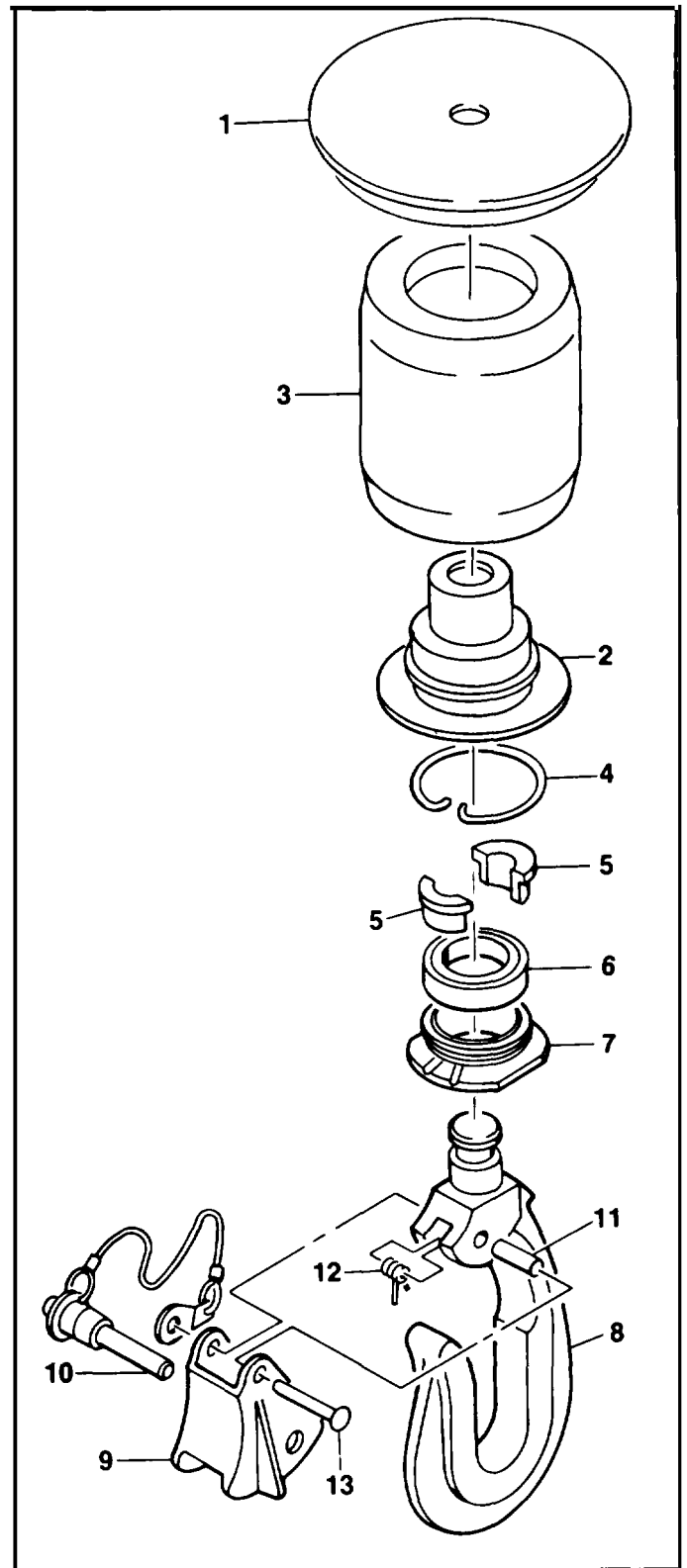
Do not allow parts to remain in cleaning solvent for extended periods of time or rust spots may form. If parts are not to be inspected immediately after cleaning, dip them in preservative oil.

Wash components in solvent and rinse thoroughly. Dry using compressed air.

3. Inspection

- a. Inspect all parts for nicks, cracks, scratches and gouges (refer to Task 2-11).
- b. Inspect for corrosion.
- c. Inspect all threaded parts for crossed, stripped and damaged threads.
- d. Inspect bearing for cracks and scoring in bearing races. Bearing must rotate smoothly with no noise, binding, or excessive axial or radial play.

GO TO NEXT PAGE



- e. Inspect torsion spring for distortion.
4. **Repair.** Repair of parts is limited to the removal of minor nicks, burrs, scratches or other surface damage using aluminum oxide cloth or fine abrasive. Clean parts thoroughly after repair. If damage is extensive, or if minor repair will affect serviceability, replace the part.
5. **Reassembly.**

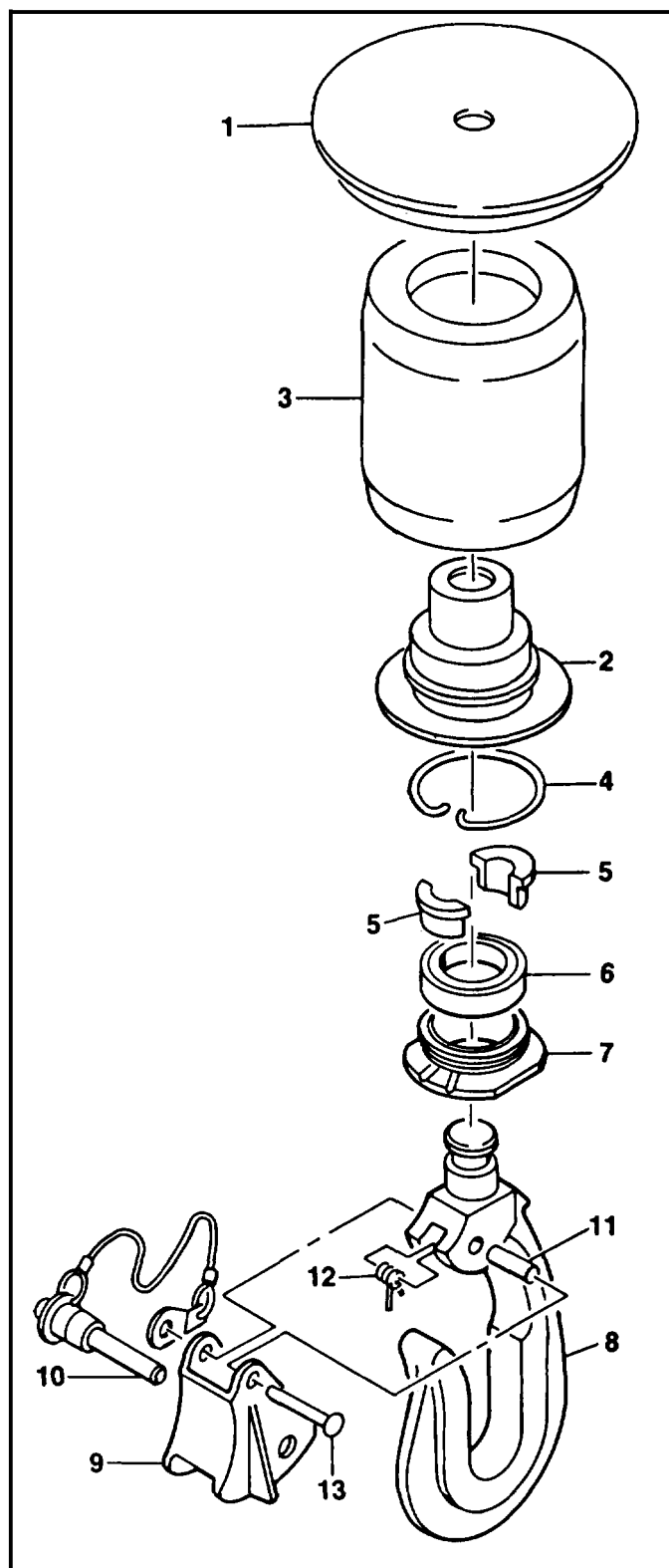
NOTE

Carrier assembly (2, 7) is a matched set. Replace only as an assembly.

- Insert torsion spring (12) with release pin (10) and bushing (11) into cable hook (8).
- Install cable hook keeper (9) onto cable hook (8) using rivet (13).
- Install bearing retainer (7) and bearing (6) onto hook (8).
- Install split retainer (5) onto hook (8) and slide into bore of bearing (6).
- Install striker disk (1) and carrier assembly (2) into cylinder (3).

FOLLOW-ON MAINTENANCE:

Install cable hook assembly
(Task 2-58)

**END OF TASK**

2-58. CABLE HOOK ASSEMBLY - REPLACE

2-58

This task covers: Removal and Installation

INITIAL SETUP**Personnel Required:**

67N, UH 1 Helicopter Repairer
 67T, UH60 Helicopter Repairer
 91W, Medevac Medics

Equipment Condition:

Hoist installed in assembly stand

Parts/Materials:

Petrolatum (Item 19, App. D)
 Packing, MS28775-016
 Packing, MS28775-023

Equipment Condition Para:

Task 2-5

Tools and Test Equipment:

Tool Kit, Aircraft Mechanic
 NSN 5180-00-323-4692
 Ground Power Unit (GPU)

Reference:

None

1. Removal.

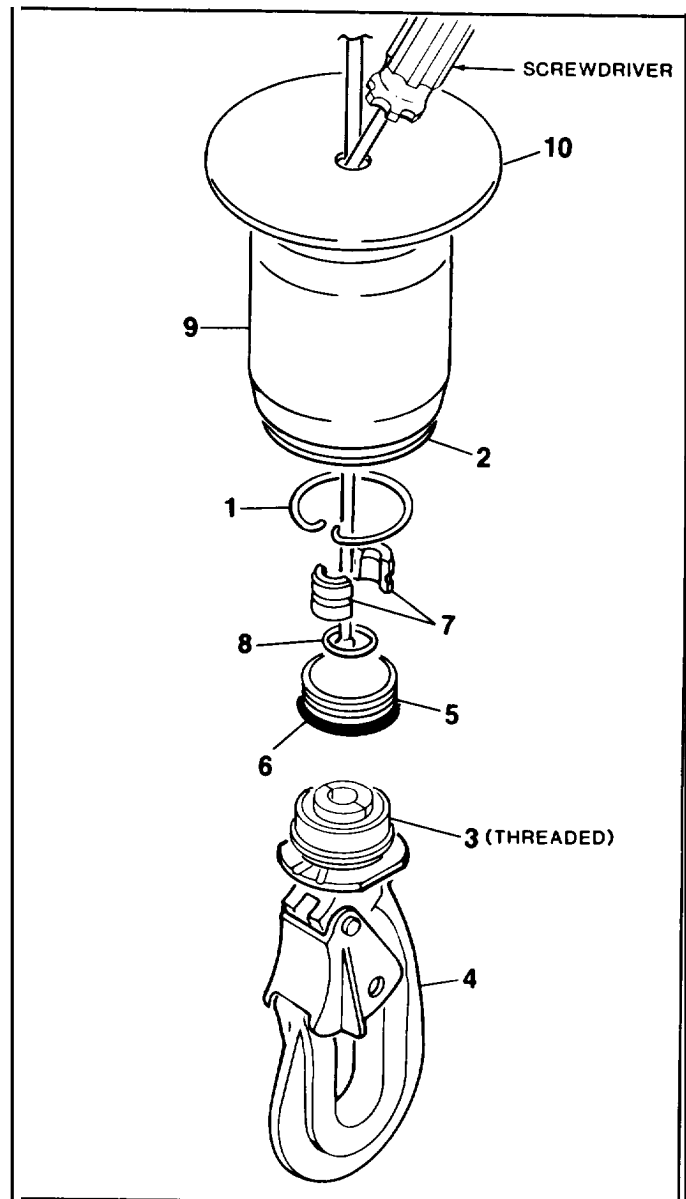
- a. Connect 28 vdc to hoist. Position control pendant CABLE UP/DOWN to DWN. Reel out cable hook assembly 2 to 3 feet.

GO TO NEXT PAGE

- b. Remove carrier assembly lock spring (1) from upper carrier (2), Separate carrier halves (2, 3).
- c. Pull cable hook (4) out of upper carrier (2).
- d. Remove cap seal (5) from upper carrier (2). Remove and discard packing (6).
- e. Insert flat tip screwdriver through hole in top of disc (10) and push retainer (7) from carrier (2). Remove retainer from cable by removing packing (8). Discard packing.
- f. Pull cable through upper carrier (2), cylinder (9) and disc (10).

2. Installation.

- a. Insert cable through disc (10), cylinder (9) and upper carrier (2).
- b. Close retainer (7) around cable. Lubricate packing (8) and install onto assembled retainer.
- c. Grasp cable at top of upper disk (10), and pull until retainer (7) slides into recess of carrier (2).
- d. Lubricate packing (6) and install on cap seal (5). Install cap seal into carrier (2) with flat side of cap seal up.
- e. Install cable hook (4) into upper carrier (2).
- f. Screw together carrier halves (2, 3). Install carrier assembly lock spring (1).



FOLLOW-ON MAINTENANCE:

Conduct performance test
(Task 2-7)

END OF TASK

2-59. HOIST CABLE ASSEMBLY - INSPECT

2-59

This task covers: Inspection**INITIAL SETUP****Personnel Required:**

67N, UH1 Helicopter Repairer
 67T, UH60 Helicopter Repairer
 91W, Medevac Medics

Equipment Condition:

Hoist installed in helicopter or assembly stand

Parts/Materials:

None

Equipment Condition Para:

Task 2-5

Tools and Test Equipment:

Cable Spool, 42277-730 or
 equivalent
 Leather Gloves, MIL-G-2366
 Micrometer

References:

General Aircraft Maintenance Manual
 TM 1-1500-204-23
 Aircraft Weapons Systems Cleaning and Corrosion Control
 TM 1-1500-344-23

WARNING

To avoid injury to personnel from broken wire strands, leather gloves must be worn at all times when handling cable assembly.

CAUTION

Protect hoist cable from damage. Do not allow kinks or bends to occur. Maintain hook weight on cable at all times (pull downward on cable while reeling out and in). Feed onto cable spool, coil the cable into a suitable container or onto a protective pad which will prevent cable contact with the ground or over abrasive surfaces.

NOTE

Continued use of a specific length of the cable cause a bird cage effect at the ball and hook. The bird caging effect could be avoided if a stretch of 250 feet with a training load were done two times.

As the cable is reeling in, check for correct alignment and lay of cable on the cable drum. Make sure the cable lays evenly on the drum. Make sure there is a tension applied to the cable, that the boom head cable roller guides and the pressure roller assembly rotates freely and that there is no interference to the reeling in of the cable. If applicable, apply lubricating oil, MIL-L-23699 or MIL-L-7808, to low lint cleaning cloth, MIL-C-85043, Type II. As the cable is reeling in, apply a light coating, MIL-C-8504, Type II. As the cable is reeling in, apply a light coating of lubricating oil using the low line cleaning cloth.

1. Inspection.

- a. Inspect hoist cable while reeling out for broken wires, bird caging, flattened areas, abrasion, necking or other visible damage refer to (Task 2-11).
- b. Inspect cable marking. Cable must be painted or dyed the last 20 feet of each end of cable.

END OF TASK

2-59. HOIST CABLE ASSEMBLY - INSPECT (cont)

2-59

2. Cable Measurement Procedures**NOTE**

The rescue hoist cable assembly is from 0.188 to 0.194 inch (4.775 to 4.928mm) diameter when new. Replace cable if at any position, the cable diameter is less than 0.185 inch (4.699mm).

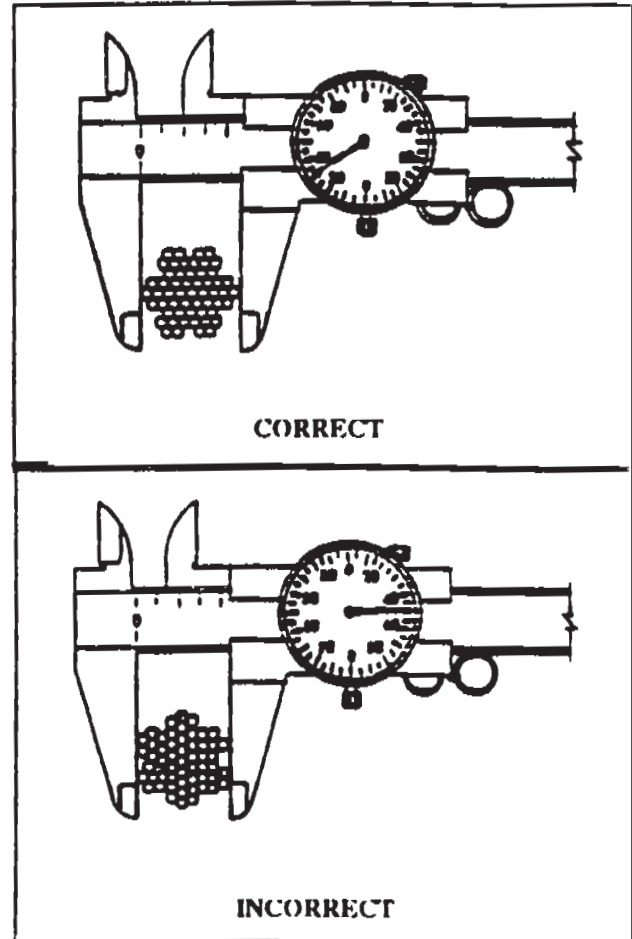
- a. Measure the diameter of the cable assembly at 25 foot (7.62mm) intervals.
- b. Check at any position where it is believed that wear or necking may have occurred.

WARNING

Performing hoist sorties, (always using same cable length) extending and retracting the cable without weight applied to the cable assembly can cause bird caging.

FOLLOW-ON MAINTENANCE:

Replace hoist cable assembly (Task 2-60).

**END OF TASK**

This task covers: **Removal and Installation**

INITIAL SETUP

Personnel Required:

67N, UH1 Helicopter Repairer (2)
67T, UH60 Helicopter Repairer (2)
91W, Medevac Medics

Parts/Materials:

Insulation Sleeving (Item 14, App. D)
Petrolatum (Item 19, App. D)
Screw, AN3H26A (Item 5, App. D)

Tools and Test Equipment:

Tool Set, Aviation Unit Maintenance
NSN 4920-00-567-0467
Tool Kit, Aircraft Mechanic
NSN 5180-00-323-4692
Cable spool, 42277-730 or equivalent
Ground Power Unit (GPU)

Equipment Condition:

Hoist installed in helicopter or assembly stand
Cable hook assembly removed.

Equipment Condition Para:

Task 2-5
Task 2-58

References:

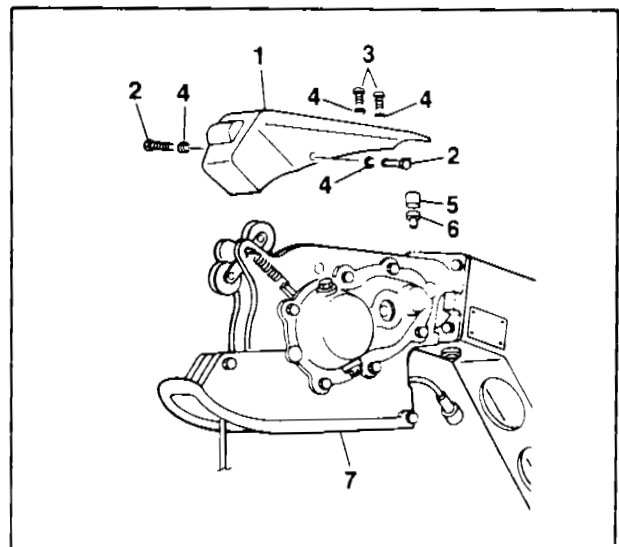
Aircraft Electrical and Electronic Manual
TM 55-1500-323-24

1. Removal.

WARNING

Rescue hoist cable cutter contains an explosive cartridge. Use extreme care when handling to prevent injury to personnel. Static producing clothing prohibited. Install piece of aluminum foil between cartridge pins when disconnecting harness.

- a. Disconnect cable cutter harness from cable cutter
- b. Remove pressure roller cover (1) from boom head assembly (7) by removing screws (2, 3) and washers (4).
- c. Remove cable cutter cap (5) and anvil (6)



GO TO NEXT PAGE

2-60. HOIST CABLE ASSEMBLY - REPLACE (cont)

2-60

- d. Remove cover plate (8) and lanyard (9) from upper support (10) by removing screws (11).

CAUTION

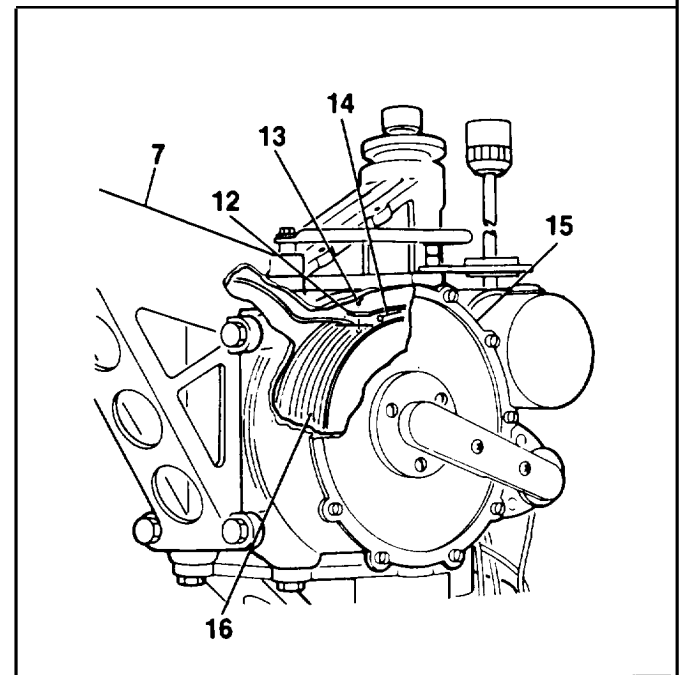
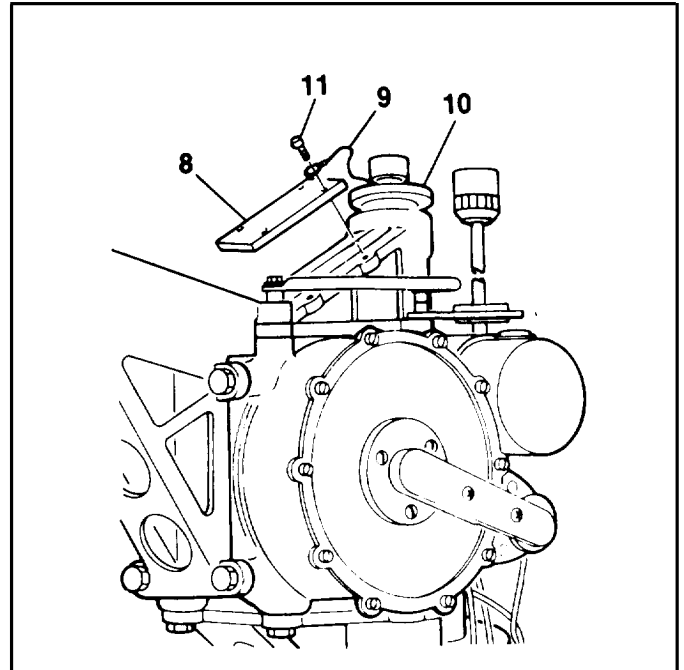
Protect hoist cable from damage. Do not allow kinks or bends to occur. Maintain hook weight on cable at all times. Feed onto cable spool or into suitable container.

- e. Connect 28 vdc to hoist. Position control pendant CABLE UP/DOWN switch to DWN.
- f. Reel out hoist cable until winch motor stops. Approximately 5 to 7 wraps of cable shall remain on drum.
- g. Locate override switch on underside of limit switch drive assembly. Depress switch and move control pendant switch to DWN.
- h. Reel out hoist cable until one wrap remains on drum.
- i. Disconnect electrical power.
- j. Reach in through access hole at top of winch housing (15), Install holding screw, AN3H25A (13) into cable retainer (12).
- k. Unscrew setscrew. Using a flat tip screwdriver, move cable assembly (14) off cable retainer (12). Remove cable retainer and release cable.

CAUTION

Ensure cable drum (16) does not rotate during cable removal. Rotation will cause misalignment of drum and limit switches, resulting in component malfunction.

- l. Pull hoist cable (14) out of winch housing (15) and through boom head assembly (7).

**GO TO NEXT PAGE**

2-60. HOIST CABLE ASSEMBLY - REPLACE (cont)

2-60

- m. Raise cable roller assembly and feed cable through cable cutter and over sheave.

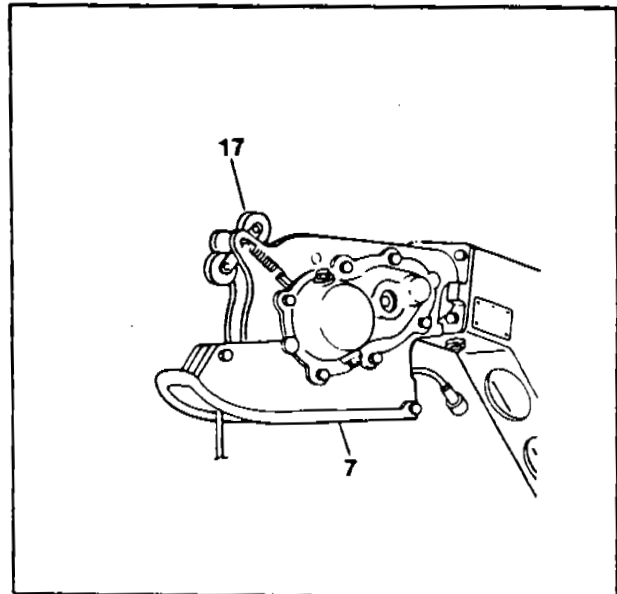
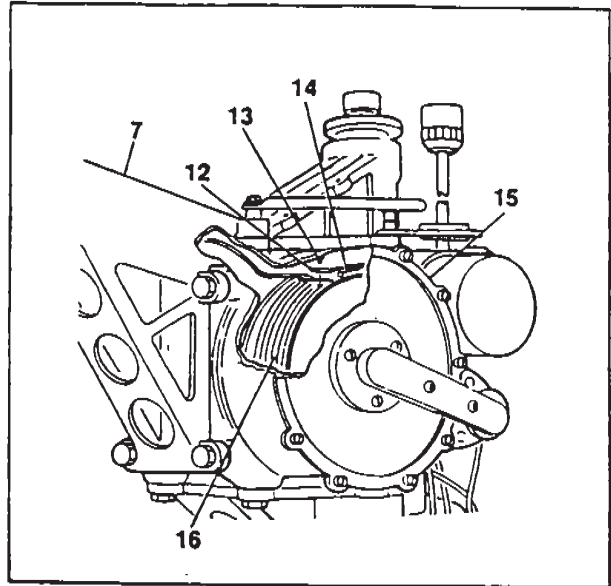
2. **Installation****WARNING**

DELETED

CAUTION

Protect hoist cable from damage. Do not allow kinks or bends to occur. Maintain hook weight on cable at all times.

- Connect 28 vdc to hoist. Position control pendant switch to UP.
- Reel hoist until drum has moved all the way toward breather side and has started to return. Position drum with cable shoe up and until approximately 1/4 inch of drum flange is visible.
- Disconnect electrical power
- Install cable (14) through actuator arm and cable guard. Raise roller assembly (17) and insert cable over sheave assembly. Pull approximately 4 feet of cable between roller and sheave assemblies. Insert cable through cable cutter.
- Insert cable into winch housing (15). Wrap cable once around cable drum (16). Insert cable ball into cable retainer (12).
- Install retainer (12) using holding screw, AN3H26A (13) to align retainer to drum (16). Ensure cable (14) is seated in proper groove. Tighten setscrew. Remove screw (13).

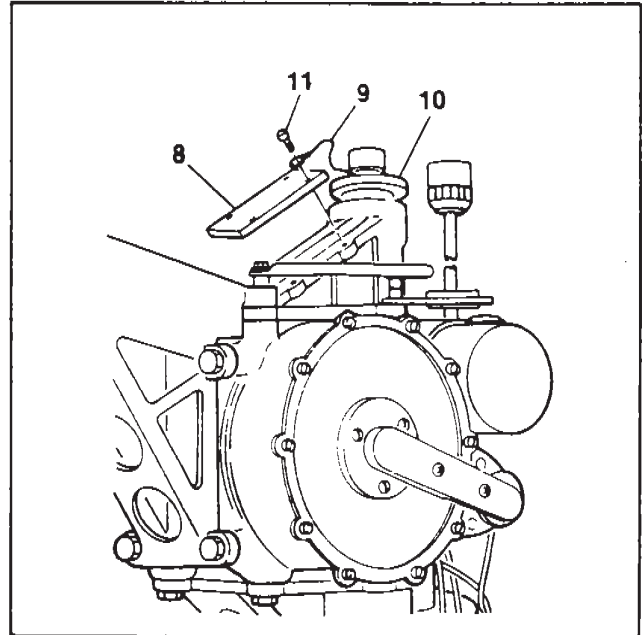


GO TO NEXT PAGE

2-60. HOIST CABLE ASSEMBLY - REPLACE (cont)

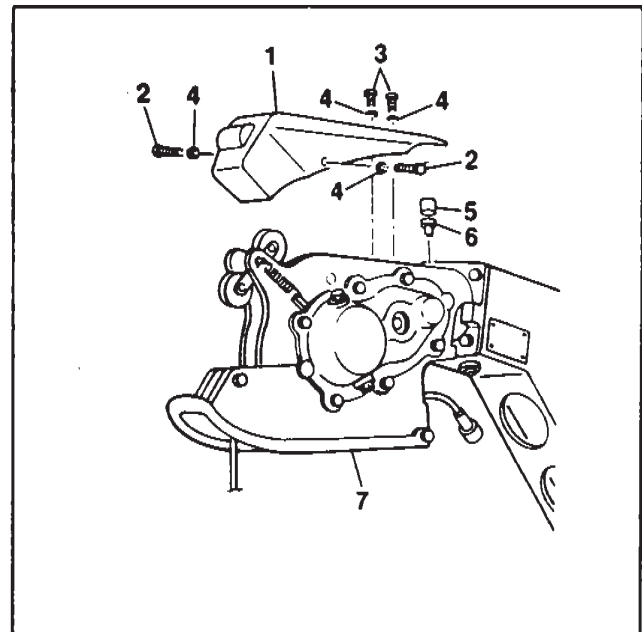
2-60

- g. Connect 28 vdc to hoist.
- h. Position control pendant switch to UP. Reel in cable until five to seven wraps are visible on drum
- i. Move control pendant switch to DWN. Reel out cable until SW1 switch actuates and stops motor. Three wraps shall be visible on drum
- j. Adjust limit switch drive assembly as required (Task 2-54)
- k. Ensure cable does not rub on sides of cable cutter barrel. Adjust as required by aligning the winch assembly (Task 2-47)
- l. If required, install heat shrinkable sleeving with a 3/8 inch inside diameter 3 - 4 inch long) onto hook end of cable assembly as follows:



- (1) Lubricate swaged ball on hook end of cable. Slide tubing over swaged ball and align tubing with the end of shank on ball.
- (2) Heat shrink tubing tightly in place in accordance with TM 55-1500-323-24

- m. Install cover plate (8) and lanyard (9) to upper support (10) using screws (11).
- n. Install anvil (6) and cable cutter cap (5).
- o. Install pressure roller cover (1) using screws (2, 3) and washers (4).

**FOLLOW-ON MAINTENANCE:**

- Install cable hook assembly (Task 2-58)
- Conduct performance check (Task 2-7)

END OF TASK

2-61. LEVEL WIND SHOE - INSPECT

2-61

This task covers: Inspection

INITIAL SETUP

Personnel Required:

67N, UH1 Helicopter Repairer
 67T, UH60 Helicopter Repairer
 91W, Medevac Medics

Equipment Condition:

Hoist installed in assembly stand
 Level wind shoe removed.

Parts/Materials:

None

Equipment Condition Para:

Task 2-5
 Task 2-62

Tools and Test Equipment:

None

References:

General Aircraft Maintenance Manual
 TM 1-1500-204-23
 Aircraft Weapons Systems Cleaning and Corrosion Control
 TM 1-1500-344-23

1. Inspect level wind shoe for nicks, cracks, scratches and dents (refer to Task 2-11).
2. Inspect for corrosion (refer to Task 2-11).
3. Inspect retaining ring and shoe retainer to ensure security.

FOLLOW-ON MAINTENANCE:

Replace level wind shoe
 (Task 2-62)

END OF TASK

2-62. LEVEL WIND SHOE - REPLACE

2-62

This task covers: **Removal and Installation**

INITIAL SETUP**Personnel Required:**

67N, UH1 Helicopter Repairer
 67T, UH60 Helicopter Repairer
 91W, Medevac Medics

Equipment Condition:

Hoist installed in assembly stand
 Winch assembly drained
 Hoist cable removed

Parts/Materials:

Lockwire (Item 18, App. D)
 Locktite Compound (Item 16, App. D)
 Screw, AN3H26A (Item 5, App. D)

Equipment Condition Para:

Task 2-5
 Task 2-45
 Task 2-60

Tools and Test Equipment:

Tool Set, Aviation Unit Maintenance
 NSN 4920-00-567-0476
 Tool Kit, Aircraft Mechanic
 NSN 5180-00-323-4692
 Micrometer

Reference:

None

1. Removal.**NOTE**

Disassemble only to the extent required to remove and repair defective components.

NOTE

Prior to disassembly, prepare a clean area for receiving parts removed. Attaching hardware shall be loosely reassembled to prevent loss.

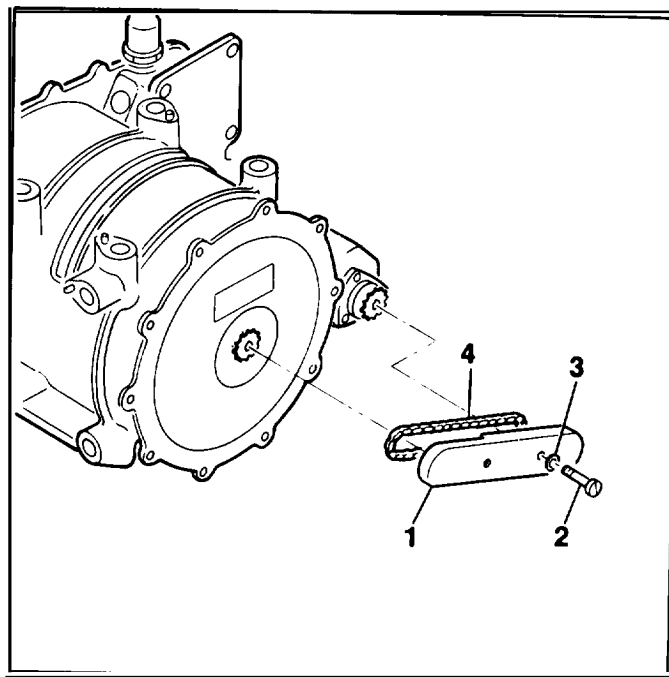
GO TO NEXT PAGE

- a. Remove chain guard cover (1) by removing screws (2) and washers (3).

NOTE

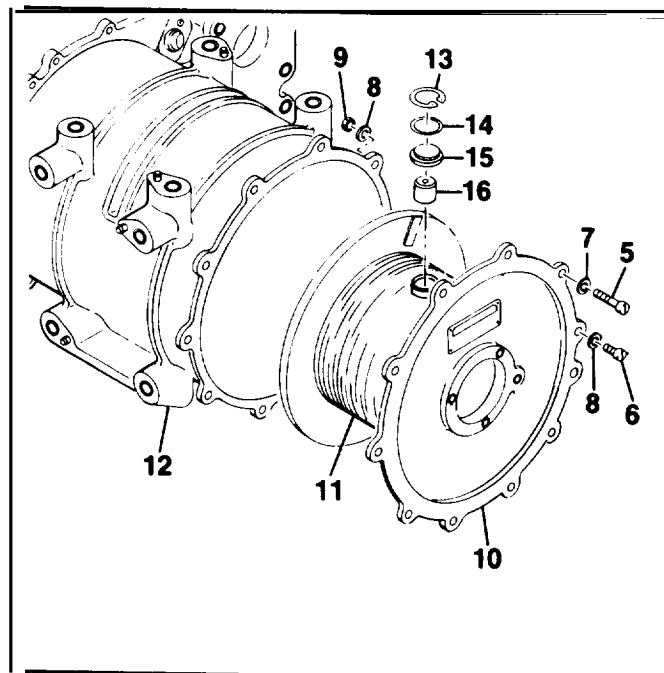
Prior to disconnecting chain (4) from limit switch drive assembly, mark sprockets of drive assembly and winch housing to preserve timing and prevent need for adjustment.

- b. Remove chain (4) by removing master link.
- c. Remove lockwire from screws (5) and discard. Remove screws (5, 6), washers (7, 8) and nuts (9).
- d. Carefully remove assembled drum cover (10) and cable drum (11) from winch housing (12).
- e. Remove retaining ring (13) and shim (14), Using holding screw, AN3H26A, remove retainer (15) and level wind shoe (16) from drum (11).



2. **Installation.**

- a. Using a 10-32 screw, install level wind shoe (16) and retainer (15). **Install shims (14) to obtain an axis end play of .004 to .008 in. between shoe and retainer.**
- b. Install retaining ring (13) into drum assembly. Align matched curved surfaces.
- c. Position drum assembly (11) near flush with drum cover (10) by rotating drum in relation to cover.
- d. Lower assembled drum (11) and cover (10) into winch housing (12). Ensure proper alignment of drum shaft and drum drive gear splines.
- e. Align cover (10) to housing (12) and secure using screws (5, 6), washers (7, 8) and nuts (9). **Torque screws to 12.15 in.lbs.**



GO TO NEXT PAGE

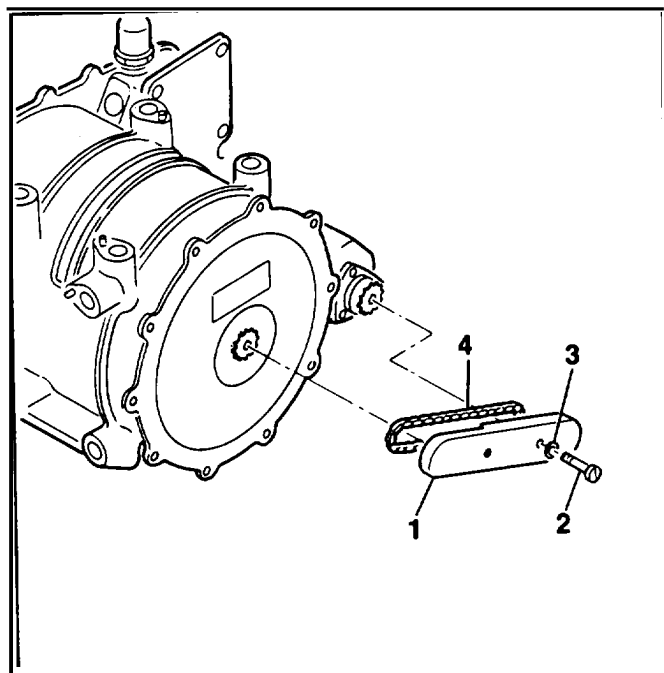
2-62. LEVEL WIND SHOE - REPLACE (cont)

2-62

- f. Position unconnected roller chain (4) onto sprockets of drum cover and limit switch drive assembly. Connect chain by installing master link.
- g. Apply locktite compound to threads of screws (2). Install chain guard cover (1) using screws and washers (3). Torque screws to 12-15 in.lbs.

FOLLOW-ON MAINTENANCE:

- Install hoist cable
(Task 2-60)
- Service winch assembly
(Task 2-45)
- Adjust limit switch drive
assembly
(Task 2-54)
- Align drum assembly
(Task 2-64)

**END OF TASK**

This task covers: Removal, Inspection and Installation

INITIAL SETUP**Personnel Required:**

67N, UH1 Helicopter Repairer
67T, UH60 Helicopter Repairer
91W, Medevac Medics

Equipment Condition:

Hoist installed in assembly stand
Level wind shoe removed

Parts/Materials:

None

Equipment Condition Para:

Task 2-5
Task 2-62

Tools and Test Equipment:

None

References:

None

1. Inspect drum assembly for nicks, cracks, scratches and dents (refer to Task 2-11).
2. Inspect for corrosion (refer to Task 2-11).
3. Inspect drum grooves for distortion and abnormalities. Check for burrs, pitting and uneven wear.
4. Inspect level wind shoe mounting hole for wear and damage. Ensure shoe seats fits tightly.
5. Inspect cable kicker for loose and worn rivets. Check for wear.

FOLLOW-ON MAINTENANCE:

Install level wind shoe
(Task 2-62)

END OF TASK

2-64. DRUM ASSEMBLY - ALIGN

2-64

This task covers: Alignment and Drum Timing

INITIAL SETUP**Personnel Required:**

67N, UH1 Helicopter Repairer
67T, UH60 Helicopter Repairer
91W, Medevac Medics

Parts/Materials:

Loctite Compound (Item 16, App. D)
Lockwire (Item 18, App. D)

Tools and Test Equipment:

Tool Set, Aviation Unit Maintenance
NSN 4920-00-567-0476
Tool Kit, Aircraft Mechanic
NSN 5180-00-323-4692
Auxiliary Power Unit (APU)
Cable Spool, 42277-730 or equivalent

Equipment Condition:

Hoist installed in assembly stand

Equipment Condition Para:

Task 2-5

References:

None

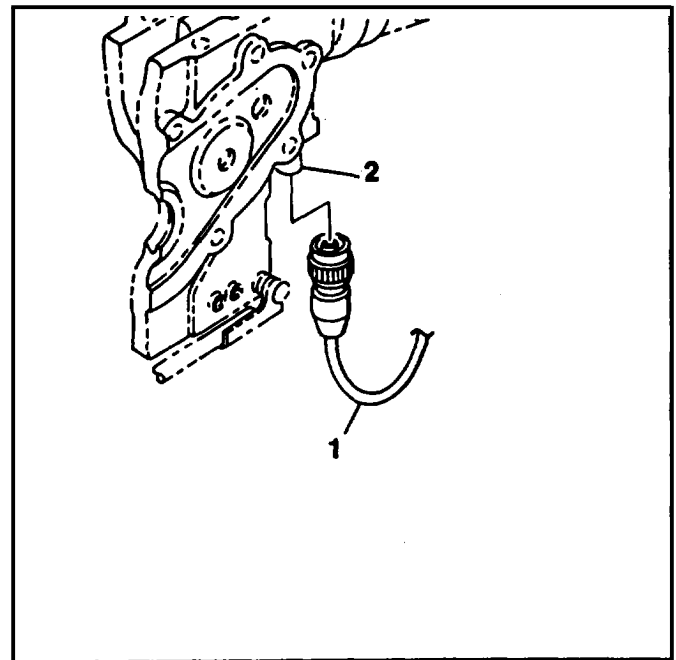
WARNING

Rescue hoist cable cutter contains an explosive cartridge. Use extreme care when handling to prevent injury to personnel. Static producing clothing prohibited. Install piece of aluminum foil between cartridge pins when disconnecting harness.

NOTE

Drum assembly alignment consists of adjusting the clearance between the cable assembly and the cable cutter. Alignment procedures are normally performed after replacement of the cable drum and cover assembly.

1. Disconnect cable cutter harness (1) from cable cutter (2).



GO TO NEXT PAGE

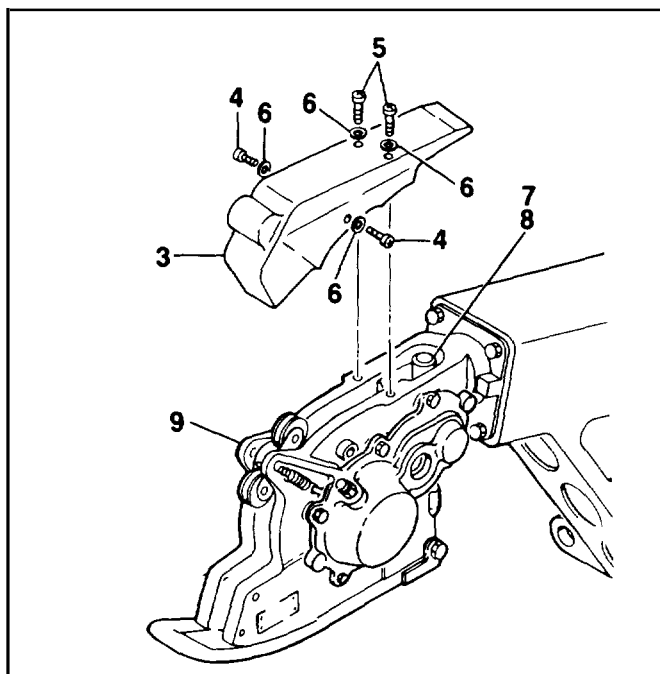
2. Remove pressure roller cover (3) from boom head assembly (9) by removing screws (4, 5) and washers (6).
3. Remove cable cutter cap (7) and anvil (8).

CAUTION

Protect hoist cable from damage. Do not allow kinks or bends to occur. Maintain hook weight on cable at all times. Feed onto cable spool or into suitable container.

NOTE

Observe hoist cable during step 4 by sighting a line along the cable assembly from the sheave assembly, through the cable cutter, and towards the winch assembly. Cable assembly shall not contact inside surface of cable cutter.



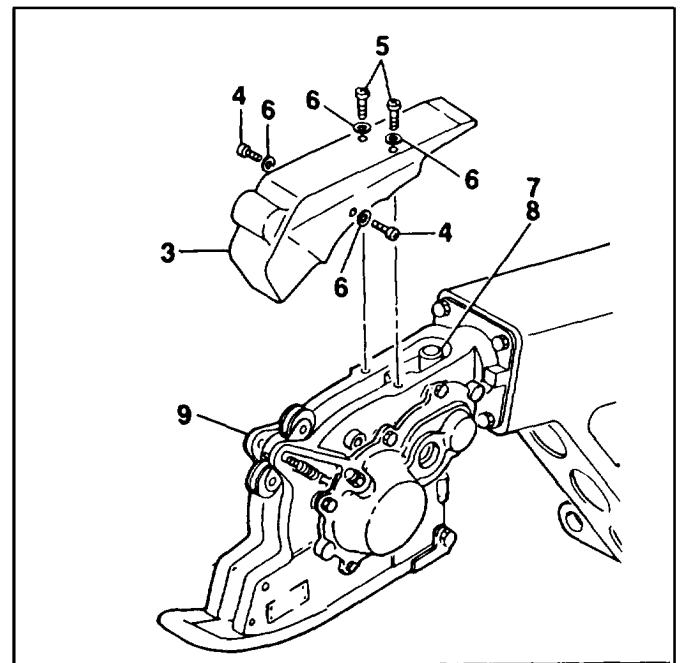
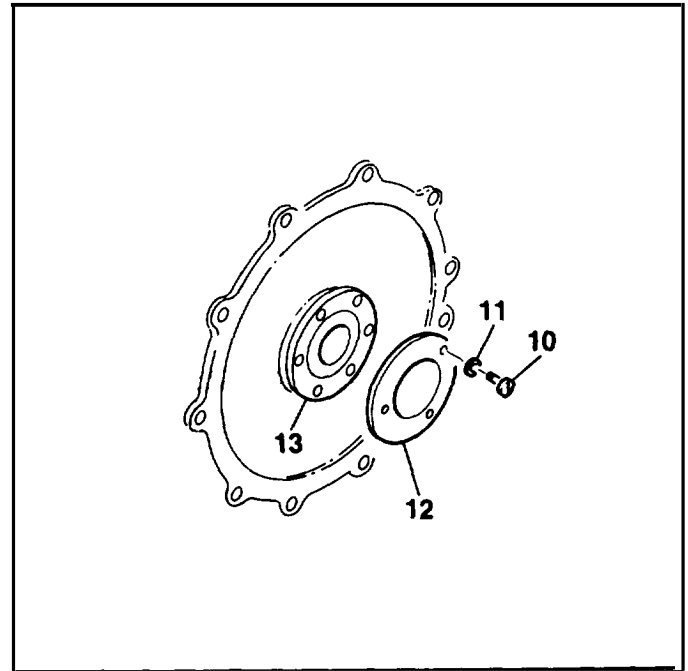
4. Connect 28 vdc to hoist. Position control pendant CABLE UP/DOWN switch to UP (to reel in extended cable) or DWN (to reel cable out).
5. Observe cable during reeling procedure, ensuring cable does not rub against inside of cable cutter. Cease operation and disconnect electrical power.

GO TO NEXT PAGE

2-64. DRUM ASSEMBLY - ALIGN (cont)

2-64

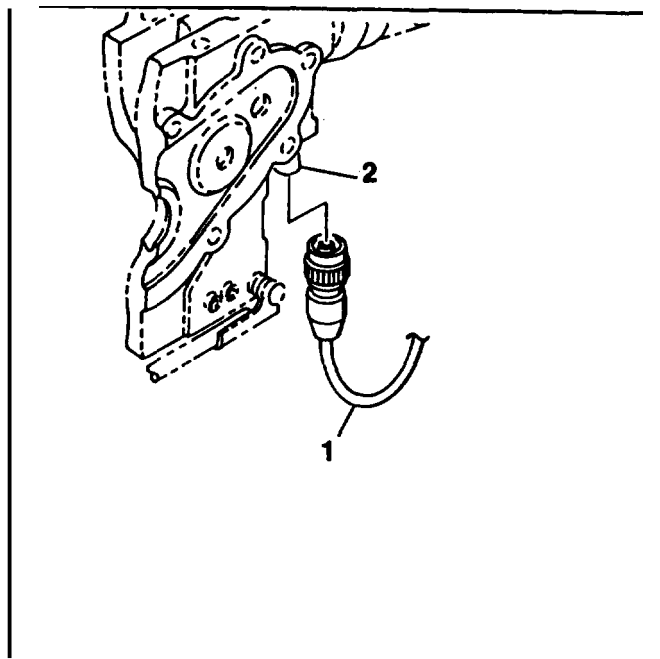
6. If hoist cable contacts inside surface of cable cutter, adjust drum alignment as follows:
- a. Remove lockwire from screws (10) and discard. Remove screws, washers (11). Pull bearing retainer (12) away from stationary gear (13).
 - b. Place a suitable tool into hole of stationary gear (13) and bearing retainer (12) and rotate stationary gear assembly (18) in the clockwise (or counter-clockwise) direction as required to obtain cable clearance.
 - c. Repeat steps 4 and 5 to ensure proper alignment and Clearance.
 - d. Position bearing retainer (12) onto stationary gear assembly (13). Install washers (11) and screws (10). Secure screws using lockwire.
7. Install cable cutter cap (7) and anvil (8).
8. Install pressure roller cover (3) onto boomhead assembly (9) and secure using screws (4, 5) and washers (6).

**GO TO NEXT PAGE**

9. Connect cable cutter harness (1) to cable cutter (2).

FOLLOW-ON MAINTENANCE:

None



END OF TASK

2-65. ELECTRICAL CABLES AND CONNECTORS - INSPECT

2-65

This task covers: Inspection

INITIAL SETUP**Personnel Required:**

67N, UH1 Helicopter Repairer
 67T, UH60 Helicopter Repairer
 68F, Aircraft Electrical Repairer
 91W, Medevac Medics

Equipment Condition:

Hoist installed in helicopter
 or assembly stand

Parts/Materials:

None

Equipment Condition Para:

Task 2-5

Tools and Test Equipment:

None

References:

None

-
1. Inspect for corrosion (refer to Task 2-11).
 2. Inspect electrical wiring for frayed and broken insulation. Check for cuts and tears.
 3. Inspect electrical connector for bent, broken and missing pins. Inspect for evidence of overheating and shorting.
 4. Inspect threaded parts for crossed, stripped and damaged threads.

FOLLOW-ON MAINTENANCE:

Repair electrical cables/connectors
 (Task 2-66)

END OF TASK

2-66. ELECTRICAL CABLES AND CONNECTORS - REPAIR

2-66**This task covers: Repair****INITIAL SETUP****Personnel Required:**68F, Aircraft Electrical Repairer
91W, Medevac Medics**Equipment Condition:**Hoist installed in assembly stand
Electrical cable removed**Parts/Materials:**

None

Equipment Condition Para:Task 2-5
Task 2-67**Tools and Test Equipment:**Tool Kit, Electrical Repairer
NSN 5180-00-323-4915**References:**Aircraft Electrical and Electronic Manual
TM 55-1500-323-24

Repair of electrical cables and connectors at the AVUM level is limited to repair of the cable cutter wiring harness assembly. Refer to electrical schematic and repair in accordance with TM 55-1500-323-24.

FOLLOW-ON MAINTENANCE:

None

END OF TASK

2-67. ELECTRICAL CABLES AND CONNECTORS - REPLACE

2-67

This task covers: Removal and Installation**INITIAL SETUP****Personnel Required:**

67N, UH1 Helicopter Repairer
 67T, UH60 Helicopter Repairer
 68F, Aircraft Electrical Repairer
 91W, Medevac Medics

Equipment Condition:

Hoist installed in helicopter
 or assembly stand

Parts/Materials

None

Equipment Condition Para:

Task 2-5

Tools and Test Equipment:

Tool Set, Aviation Unit Maintenance
 NSN 4920-00-567-0476
 Tool Kit, Aircraft Mechanic
 NSN 5180-00-323-4692

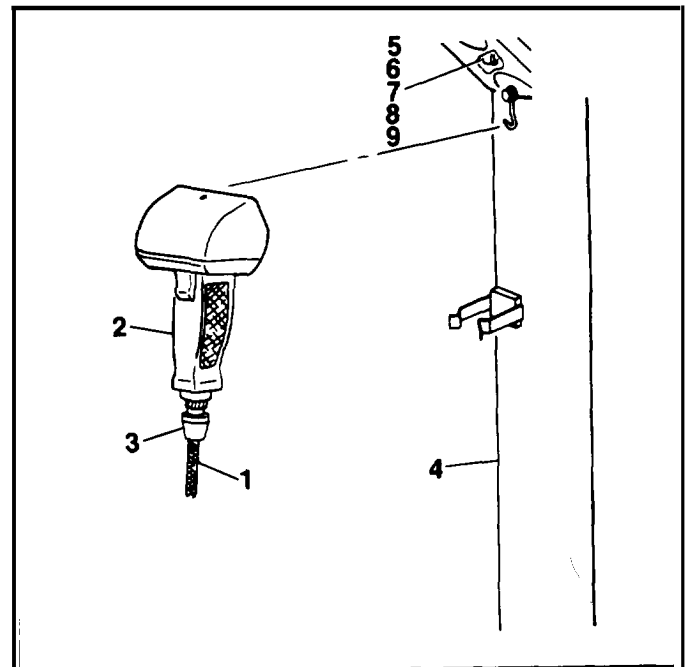
References:

Aircraft Electrical and Electronic Manual
 TM 55-1500-323-24

1. Removal.**WARNING**

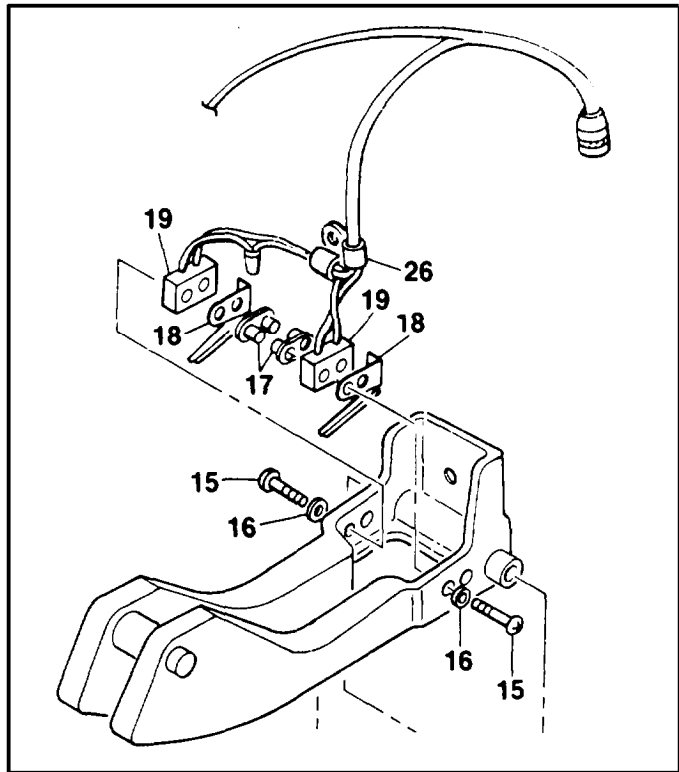
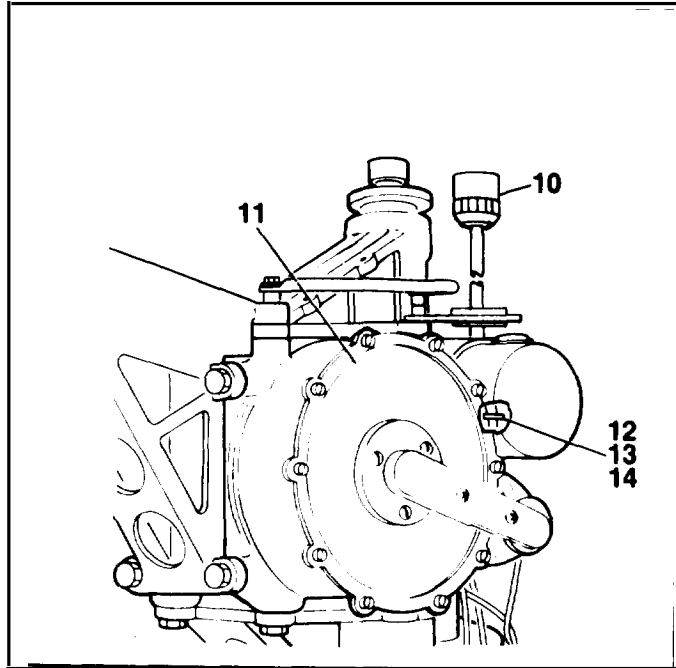
Ensure external electrical power is removed from system prior to removing electrical cables or connectors. Personnel injury could occur.

- a. Disconnect control cable (1) from control pendant (2) by unscrewing connector (3).
- b. Disconnect control cable from control panel assembly.
- c. Remove control cable (1) from boom position support assembly (4) by removing clamp (5), screws (6, 7), nut (8) and bracket (9).

**GO TO NEXT PAGE**

2-67. ELECTRICAL CABLES AND CONNECTORS - REPLACE (cont)

- d. Disconnect umbilical cable (10) from external power source.
- e. Disconnect umbilical cable from control panel assembly.
- f. Remove umbilical cable (10) from winch assembly (11) by removing clamp (12), screw (13) and nut (14).
- g. Remove screws (15) washers (16) and nutplate assemblies (17).
- h. Carefully remove actuator leaves (18) from microswitch assemblies (19).



GO TO NEXT PAGE

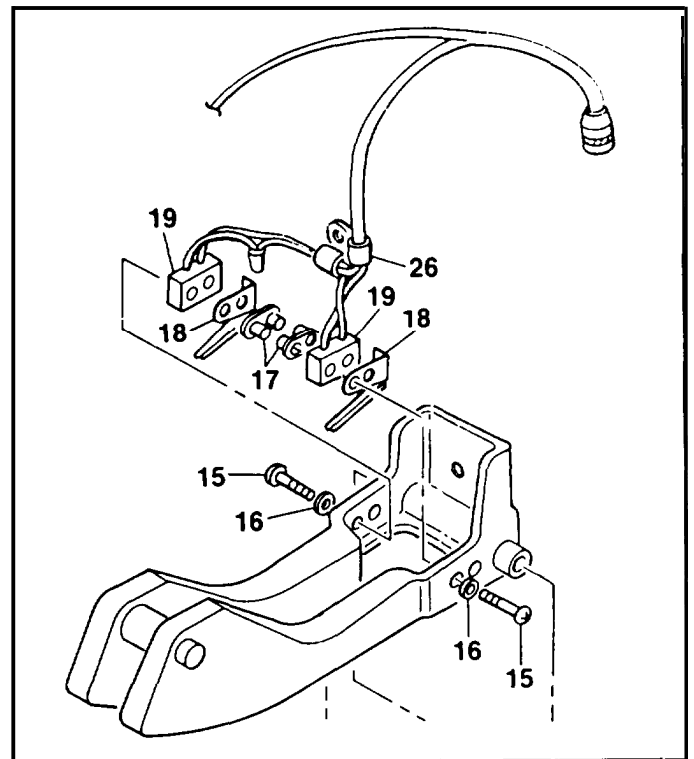
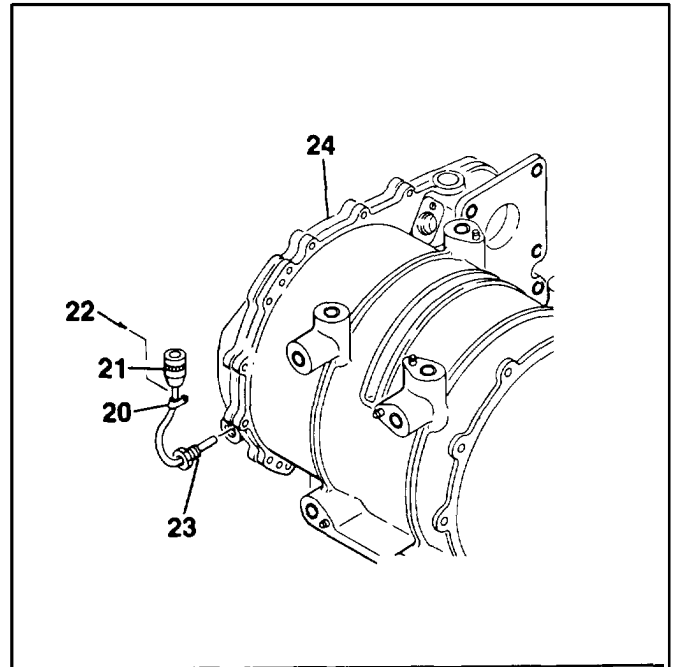
2-67. ELECTRICAL CABLES AND CONNECTORS - REPLACE (cont)

2-67

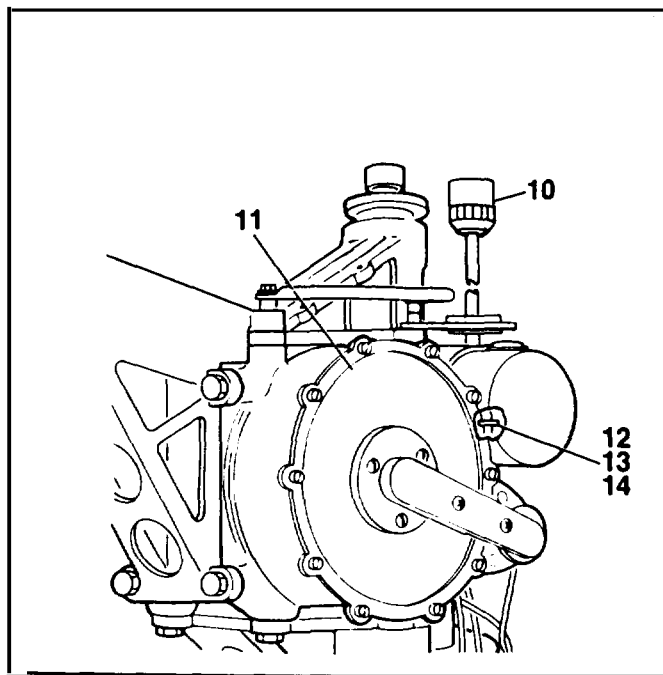
- i. Remove clamp (20) from connector (21) by removing screws (22).
- j. Using a suitable pin removal tool, remove pins from connector (21).
- k. Remove heat shrink and electrical braid from thermal switch (23). Unscrew thermal switch from winch housing (M).

2. Installation.

- a. Screw thermal switch (23) into winch housing (24). Install electric braid and heat shrink tubing on leads of switch.
- b. Using a suitable pin installation tool, install pins into connector (21). Twist ends of electric braid to secure and shrink heat shrink tubing in place.
- c. Install clamp (20) onto connector (21) using screws (22).
- d. Install actuator leaves (18) and position with microswitch assemblies (19) into boom housing. Secure using screws (15), washers (16) and nutplates (17).

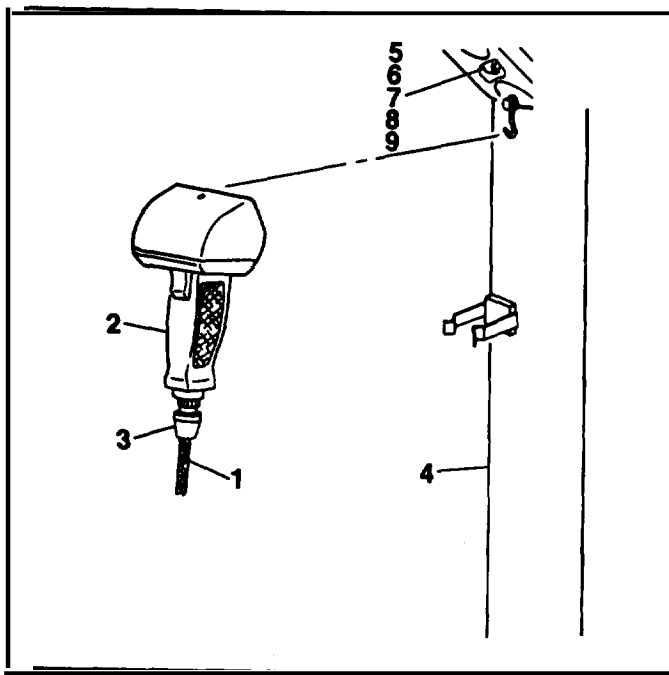
**GO TO NEXT PAGE**

- e. Install umbilical cable (10) to winch assembly (11) using clamp(12), screw (13) and nut (14).
- f. Connect umbilical cable to control panel assembly.
- g. Feed umbilical cable (10) through bracket (12).
- h. Install control cable (1) onto boom position support assembly (4) using champ (5), screws (6, 7), nut (8) and bracket (9).
- i. Connect control cable to control panel assembly.
- j. Connect control cable (1) to control pendant (2) by tightening connector (3).



FOLLOW-ON MAINTENANCE:

None



END OF TASK

SECTION VI. PREPARATION FOR STORAGE OR SHIPMENT

2-68. PREPARATION FOR STORAGE OR SHIPMENT

2-68

This task covers: Inspection, Preservation, and Packaging**INITIAL SETUP****Personnel Required:**

67N, UH1 Helicopter Repairer (2)
 67T, UH60 Helicopter Repairer (2)
 91W, Medevac Medics

Equipment Condition:

Hoist installed in assembly stand
 Boom head assembly drained
 Winch assembly drained

Parts/Materials:

None

Equipment Condition Para:

Task 2-5
 Task 2-18
 Task 2-45

Tools and Test Equipment:

Reusable Shipping Container, 42305R11

References:

Preservation and Packaging
 MIL-STD-1188
 Material Condition Marking
 MIL-STD-129

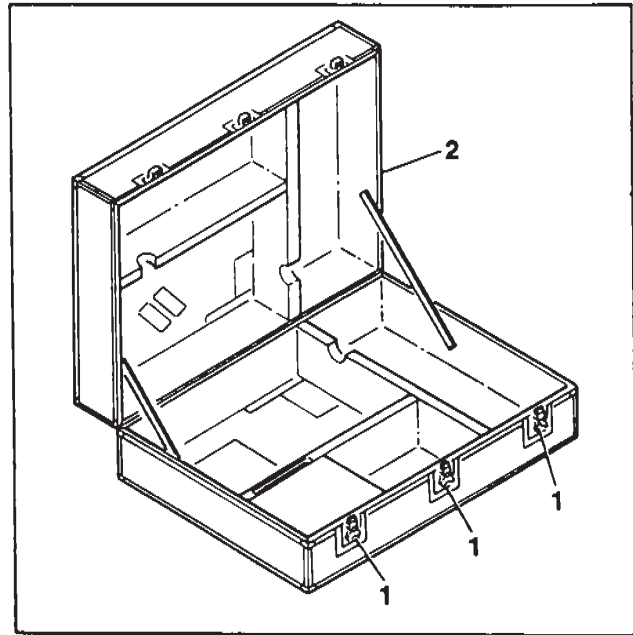
-
1. **Inspection.** Inspect hoist for damage in accordance with inspection criteria in Task 2-11. If hoist has been damaged, report damage on a two material condition tags in accordance with MIL-STD-129. Attach one tag directly onto hoist. Attach second tag to the outside of the reusable shipping container after installation of hoist. Ensure tags are secured in such a manner that will afford maximum protection from handling and weather.
 2. **Preservation.** Rescue hoist shall be preserved in accordance with MIL-STD- 1188, Level A.

GO TO NEXT PAGE

3. **Packaging.****WARNING**

When hoist is packaged for shipment or storage, refire kit, P/N 42277E182, reference in change 3, page C-3-2 Item Number 74A is to be removed from the cable cutter. The cable cutter, P/N 42277E336 may be left in hoist but the refire kit which is an explosive charge and component of the cable cutter must be removed prior to shipment or storage. In addition storage case should be marked externally to indicate that explosive charge has been removed.

- a. Place rescue hoist reusable shipping container, Part Number 42305R11 on a flat surface. Allow adequate work space for installation of rescue hoist.
- b. Lift three overcenter latch handles (1) and unlatch to release top of shipping container (2).
- c. Grasp top of shipping container (2) and lift up to open.
- d. With a helper, lift hoist and place into shipping container.
- e. Secure cable hook in container using internal retaining strap.
- f. Ensure material condition tag is securely attached to hoist. Close top of shipping container (2) and secure using three overcenter latch handles (1).

**FOLLOW-ON MAINTENANCE:**

None

CHAPTER III

AVIATION INTERMEDIATE MAINTENANCE (AVIM)
MAINTENANCE INSTRUCTIONSSection I. REPAIR PARTS, SPECIAL TOOLS; TEST, MEASUREMENT,
AND DIAGNOSTIC EQUIPMENT (TMDE); AND SUPPORT EQUIPMENT

3-1. Common Tools and Equipment. For authorized common tools and equipment, refer to the Modified Table of Organization and Equipment (MTOE) applicable to your unit.

3-2. Special Tools, TMDE, and Support Equipment. Refer to Repair Parts and Special Tools List, Appendix C, for special tools and support equipment. Refer to Test Equipment List, Appendix G, for TMDE.

3-3. Repair Parts. Repair parts are listed and illustrated in Appendix C of this manual.

Section II. SERVICE UPON RECEIPT

3-4. SERVICE UPON RECEIPT OF MATERIAL

3-4

This task covers: Unpacking and checking unpacked equipment

INITIAL SETUP

Personnel Required:

67N, UH1 Helicopter Repairer (2)
 67T, UH60 Helicopter Repairer (2)
 91W, Medevac Medics

Equipment Condition:

Hoist in shipping container

Parts/Materials:

None

Equipment Condition Para:

None

Tools and Test Equipment:

Assembly Stand, 42277-808 or
 equivalent
 Shipping Container, 42305R11

References:

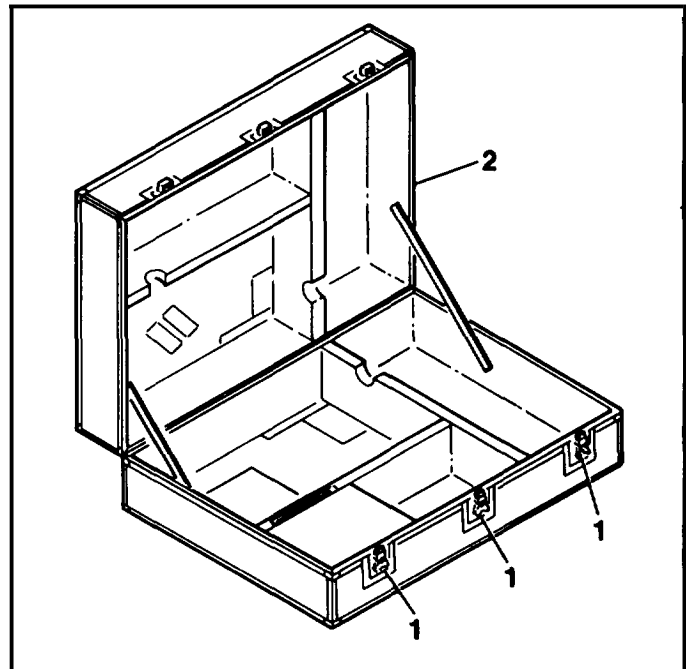
None

1. **Unpacking.**

NOTE

Place rescue hoist reusable shipping container, Part Number 42305R11 on a flat surface. Allow adequate work space for removal of rescue hoist.

- a. Lift three overcenter latch handles (1) and unlatch to release top of shipping container (2).
- b. Grasp top of shipping container (2) and lift up to open.
- c. Release retaining internal retaining strap to remove hoist cable hook.



GO TO NEXT PAGE

3-4. SERVICE UPON RECEIPT OF MATERIAL(cont)

3-4

- d. With a helper, lift hoist from shipping container.
- e. Place rescue hoist on a suitable work surface (or in hoist assembly stand, Part Number 42277-808) for inspection.

2. Checking Unpacked Equipment.

- a. Inspect the hoist for damage incurred during shipment. If the equipment has been damaged report the damage on DD Form 6, Packaging Improvement Report.
- b. Check the hoist against packing slip to see if shipment is complete. Report all discrepancies in accordance with instructions of DA PAM 738-751.
- c. Check all tags and forms accompanying the hoist to determine the reason (if any) for removal from service.
- d. Do not remove any forms or tags that are attached to the hoist until unit is installed and ready for operation. When installed, remove forms and tags and forward to Quality Control (QC) section.

FOLLOW-ON MAINTENANCE:

None

END OF TASK

This task covers: Installation Instructions for Helicopter and Assembly Stand

INITIAL SETUP

Personnel Required:

67N, UH1 Helicopter Repairer (2)
67T, UH60 Helicopter Repairer (2)
91W, Medevac Medics

Equipment Condition:

Hoist unpacked from shipping
container

Parts/Materials:

None

Equipment Condition Para:

Task 3-4

Tools and Test Equipment:

Tool Kit, Aircraft Mechanic
NSN 5180-00-323-4692
Assembly Stand, 42277-808 or
equivalent

References:

UH1 Series Helicopter Maintenance Manual
TM 55-1520-210-23-2
60 Series Helicopter Maintenance Manual
TM 55-1520-237-23-4

WARNING

Ensure external electrical power is removed from system prior to installing rescue hoist. Activated electricity could cause injury to personnel or damage to equipment.

WARNING

Enlist the help of an aide during installation to prevent injury or component damage.

1. **Helicopter Installation.** Install rescue hoist to helicopter in accordance with appropriate UH1 or UH60 series helicopter maintenance manual.

GO TO NEXT PAGE

3-5. INSTALLATION INSTRUCTIONS (cont)

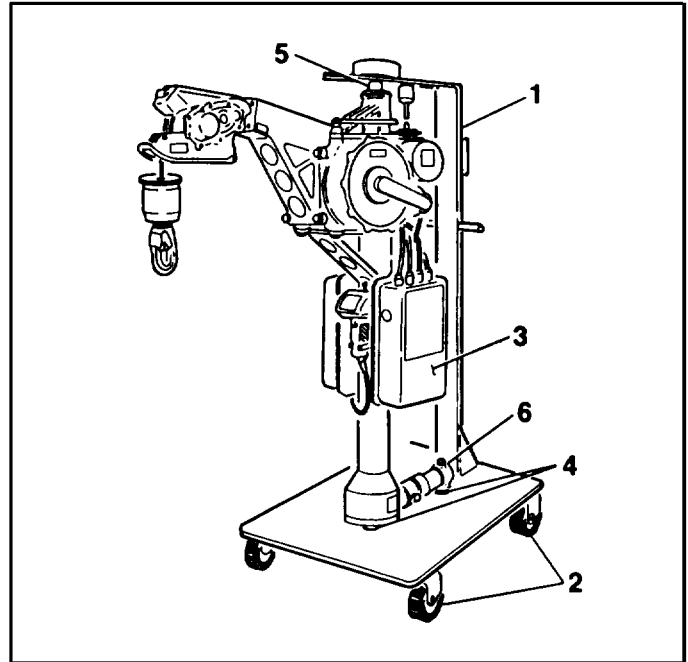
3-5

2. Assembly Stand Installation.

- a. Place assembly stand (1), Part Number 42277-808, or equivalent on a flat surface. Block casters (2) to prevent stand movement during hoist installation.
- b. Position hoist (3) into assembly stand (1), ensuring alignment of quick disconnect adapters (4) to stand reception holes.
- c. Adjust height adjuster (5) and reaction arm (6) as required to secure hoist (3).

FOLLOW-ON MAINTENANCE:

None

**END OF TASK**

This task covers: Preliminary Servicing and Adjustment of Equipment

INITIAL SETUP

Personnel Required:

67N, UH1 Helicopter Repairer (2)
 67T, UH60 Helicopter Repairer (2)
 91W, Medevac Medics

Equipment Condition:

Hoist installed in helicopter

Parts/Materials:

None

Equipment Condition Para:

Task 3-5

Tools and Test Equipment:

None

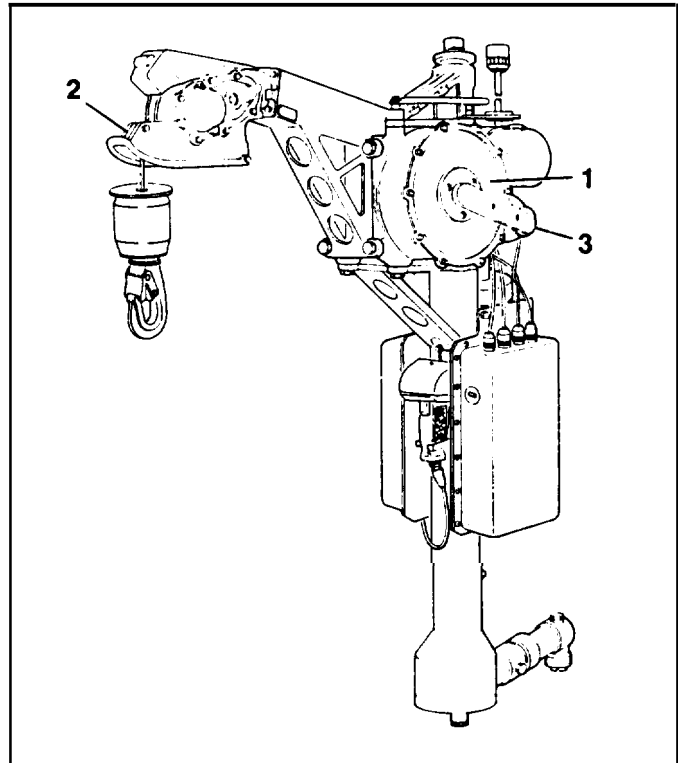
References:

None

WARNING

The hoist cable cutter contains an explosive cartridge. Use extreme caution when handling to prevent injury to personnel. Spark or static producing clothing is prohibited.

- a. Check rescue hoist lubricating oil levels by looking at level sight gauge located on winch assembly (1). Service hoist in accordance with lubrication instruction plates located on the boom head (2) and winch (3) assemblies.



GO TO NEXT PAGE

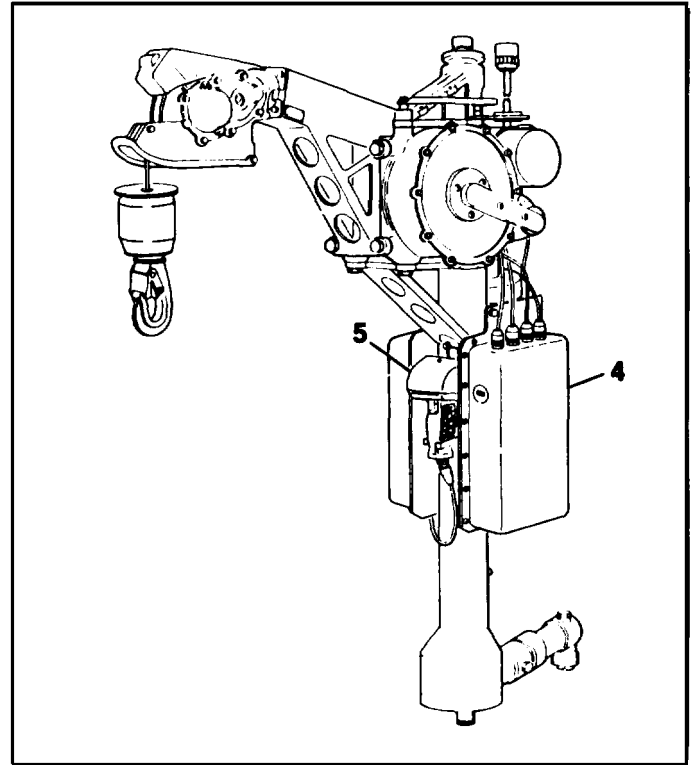
3-6. PRELIMINARY SERVICING AND ADJUSTMENT OF EQUIPMENT (cont)

3 - 6

- b. Inspect electrical cables and connectors to ensure proper electrical interconnection. Check for damage and repair as required prior to performing any operational procedures.
- c. Ensure electrical cable harnesses are properly routed, free of obstruction and clear of moving parts. Ensure harnesses are properly and securely fastened to hoist.
- d. Check control panel (4) and control pendant (5) to ensure all operational switches are in the OFF or neutral position prior to activating input power.
- e. Ensure hoist is securely installed and components properly adjusted.

FOLLOW-ON MAINTENANCE:

None

**END OF TASK**

3-7. OPERATIONAL PERFORMANCE CHECK

3-7

This task covers: Conducting After Maintenance and Daily Performance Checks on the hoist

INITIAL SETUP**Personnel Required:**

67N, UH1 Helicopter Repairer (2)
67T, UH60 Helicopter Repairer (2)
68F, Aircraft Electrical Repairer
91W, Medevac Medics

Equipment Condition:

Hoist installed in helicopter

Parts/Materials:

None

Equipment Condition Para:

Task 3-5

Tools and Test Equipment:

Ground Power Unit (GPU)
Cable Spool, 42277-730 or equivalent
Multimeter

References:

None

1. Operational Performance Check.**WARNING**

The hoist cable cutter contains an explosive cartridge. Use extreme caution when handling to prevent injury to personnel. Spark or static producing clothing is prohibited. Anytime cable cutter harness is disconnected, install piece of aluminum foil between cartridge pins and install shipping cap to prevent accidental firing.

CAUTION

During performance checks, continually observe OVER TEMP indicator, to ensure that the light is not lit.

GO TO NEXT PAGE

3-7. OPERATIONAL PERFORMANCE CHECK (cont)

3-7

- a. Connect power source to helicopter. Close rescue hoist CONT and POWER circuit breakers on pilot overhead console.

NOTE

Blue POWER ON light should be on and blower fan shall be operating.

- b. Using control pendant BOOM IN/OUT switch, rotate the swinging boom out, then in. Observe the 205 degree swing for proper operation.

NOTE

When rescue hoist is installed on left side of aircraft, pilot boom switch operates in reverse.

- c. Using pilot boom control switch, rotate the boom in, then out. Observe the 205 degree swing for proper operation.

CAUTION

During the following procedures, reel cable out from the boom head in line with the boom axis. Use care not to pull cable taut against the cable guide or roller, as kinking of the cable can result. Avoid damaging cable on rough surfaces, such as the ground. Cable from the hoist should be fed onto cable spool (or suitable substitute drum of at least 9" diameter).

NOTE

Observe that the amber CAUTION light extinguishes when 10 feet of cable is unreeled. Ensure cable speed decelerates (to approximately 67 feet per minute) when cable is within 10 feet of all out (250 feet).

- d. Position the control panel HIGH/LOW SPEED switch to HIGH.
- e. Using pilot hoist control switch, lower cable hook until all cable is reeled out.

NOTE

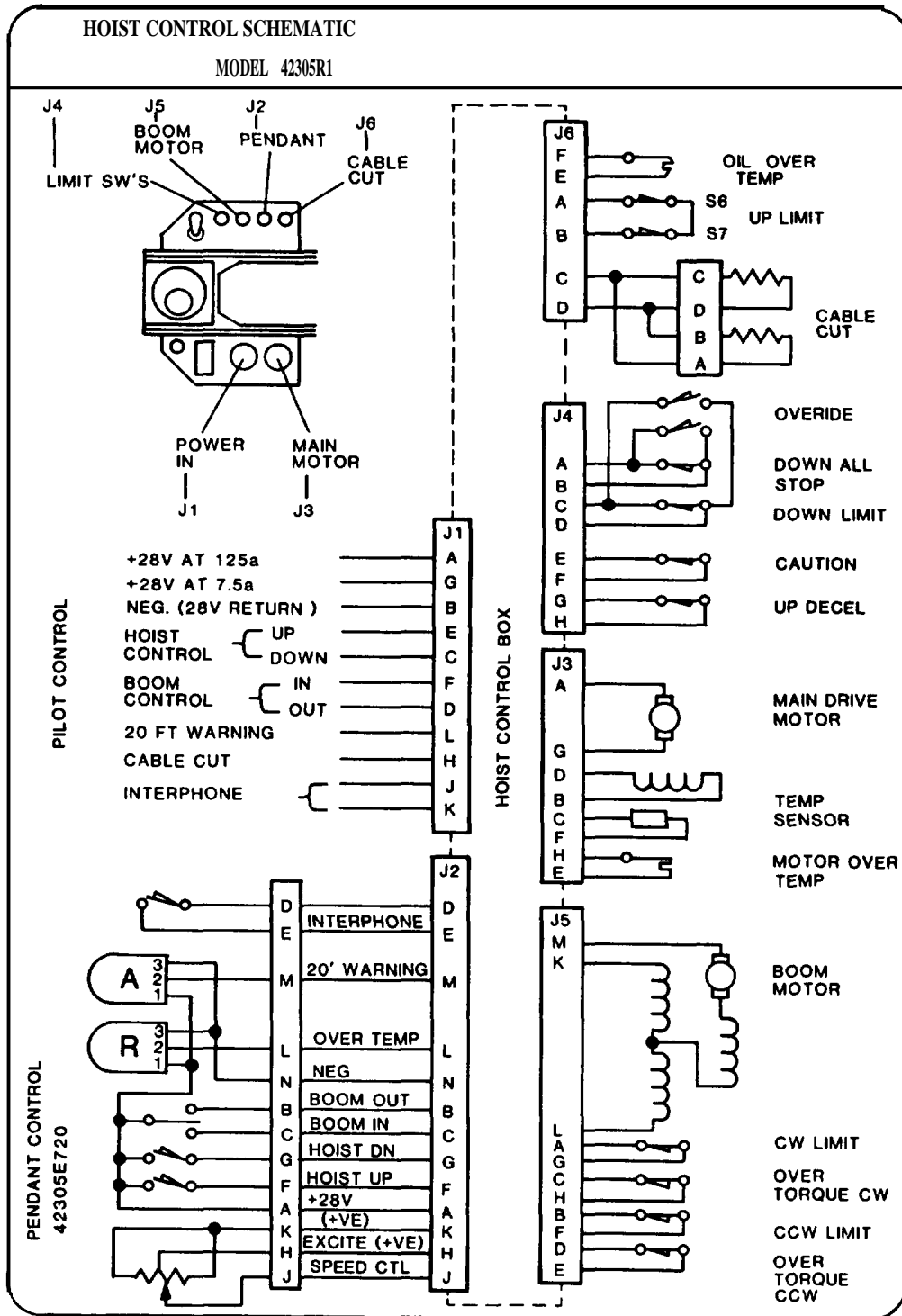
During the cable reeling in procedure, push up on actuator arm to ensure proper operation of the up-limit switch. Hoist shall stop running when arm is raised (up-limit switch actuated) and resume operation when arm is released.

NOTE

Observe that the amber CAUTION light comes on when the cable hook is within 10 feet of the boom head. Ensure cable speed decelerate (to approximately 67 feet per minute). The cable speed shall decelerate to approximately 12 feet per minute when the hook is within 18 inches of the boom head.

- f. Using pilot hoist control switch, raise cable hook until all cable is reeled in. Depress actuator arm several times during operation to ensure proper response.

GO TO NEXT PAGE



GO TO NEXT PAGE

3-7. OPERATIONAL PERFORMANCE CHECK (cont)

3-7

- g. Repeat steps b through f using the control pendant CABLE UP/DOWN switch. Using the pendant speed control lever, ensure cable speed can be varied during the reeling out operation (from 0-250 feet per minute).
- h. Place control panel HIGH/LOW SPEED switch to LOW and repeat steps b through g.
- i. Upon completion of tests, reel cable all the way in. Using control pendant BOOM IN/OUT switch, rotate the swinging boom in to stowed position.
- j. Open rescue hoist CONT and POWER circuit breakers on pilot overhead console. Disconnect power source from helicopter.

2. Systems Test.**a. Cable Cutter.**

- (1) Connect a 28 volt dc light to cable cutter connector at boom head.
- (2) Operate CABLE CUT switch at operators and pilots positions and verify that the light comes on.

b. Cooling Fan.

- (1) Apply 28 vdc across pins A and B of connector J1.
- (2) Audibly check cooling fan motor for operation. The fan shall produce a high-pitched whine.

c. Boom Over-Torque Limit Switches.

- (1) Check for continuity between pins C and D of connector J5 for the counterclockwise limit switch.
- (2) Check for continuity between pins D and E of connector J5 for the clockwise limit switch.

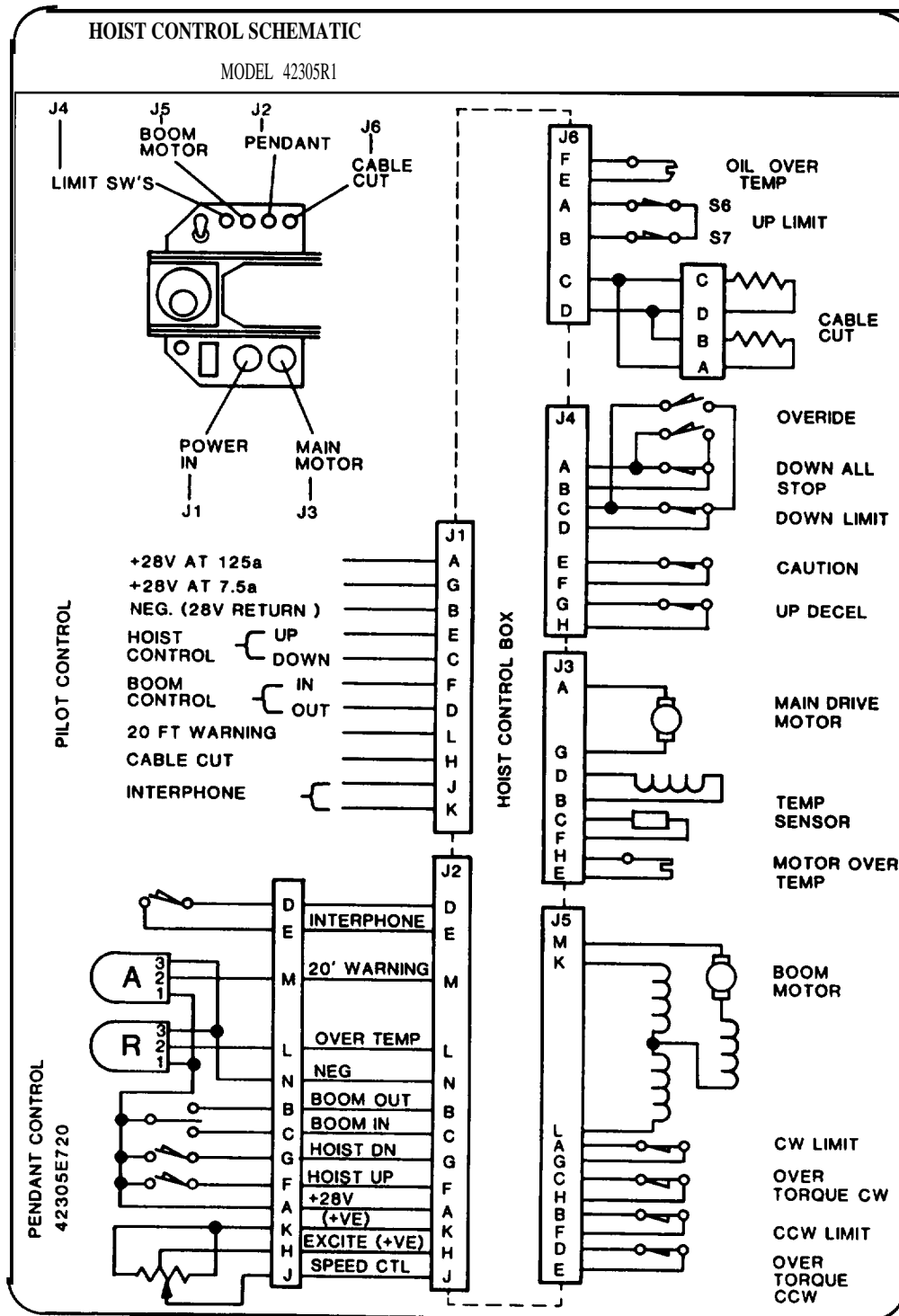
d. Boom Motor Assembly.

- (1) Ensure reaction plate and aircraft position switch are positioned properly.
- (2) Check for continuity between pins K and M of connector J5.
- (3) Check for continuity between pins L and M of connector J5.

e. Lower Limit Switch (205 Degree Rotation).

- (1) Rotate boom to clockwise position. Check for continuity between pins A and G of connector J5 for the counterclockwise limit switch.
- (2) Rotate boom to counterclockwise position. Check for continuity between pins B and F of connector J5 for the clockwise limit switch.

GO TO NEXT PAGE



GO TO NEXT PAGE

3-7. OPERATIONAL PERFORMANCE CHECK (cont)

3-7

f. Winch Temperature Sensor.

- (1) Disconnect connector J6 from control panel.
- (2) Check for continuity between pins E and F of connector J6.

g. Control Pendant BOOM IN/OUT Switch.

- (1) Disconnect connector from control pendant.
- (2) Position the BOOM IN/OUT switch to OUT and check for continuity between pins A and B of pendant connector.
- (3) Position the BOOM IN/OUT switch to IN and check for continuity between pins A and C of pendant connector.

h. Up Limit Switch.

- (1) Disconnect connector J6 from control panel. Ensure hook is not against boom head actuator.
- (2) Check for continuity between pins A and B of connector J6.

i. Hoist Input Power.

- (1) Disconnect connector J1 from control panel.
- (2) Check for 28 vdc between pins A, C and J and B(-) of connector J1.
- (3) Check for 28 vdc between pins G, C and S and B(-) of connector J1.

j. Control Pendant CABLE UP/DOWN Switch

- (1) Disconnect connector from control pendant.
- (2) Position the CABLE UP/DOWN switch to DOWN and check for continuity between pins A and G of pendant connector.
- (3) Position the CABLE UP/DOWN switch to UP and check for continuity between pins A and F of pendant connector.

FOLLOW-ON MAINTENANCE:

None

END OF TASK

Section III. PREVENTIVE MAINTENANCE CHECKS AND SERVICE (PMCS)

3-8. Introduction. This section lists and authorizes preventative maintenance checks and services (PMCS) required for the rescue hoist. The content of the PMCS tables is based upon the principles of reliability centered maintenance (RCM).

3-9. Explanation of Columns.

a. ITEM NO. Column. The number used to identify sequence of checks and services. This column shall be used as a source of item numbers for the TM Number Column on DA Form 2404, Equipment Inspection and Maintenance Worksheet, when recording results of PMCS.

b. INTERVAL Column. Indicates the time interval upon which the checks and services must be performed. Intervals are divided as follows:

- D Daily
- W Weekly
- M Monthly
- A Annually
- H Hours

c. ITEM TO BE INSPECTED Column. Indicates item and components to be inspected.

d. PROCEDURES Column. Indicates the procedure by which the check or service is to be performed. Tolerances, adjustment limits, and instrument readings are included as applicable. When replacement or repair of a component is required, the procedures column will direct personnel to the appropriate task.

TABLE 3-1. INTERMEDIATE PREVENTIVE MAINTENANCE CHECKS AND SERVICES

ITEM NO.	INTERVAL					ITEM TO BE INSPECTED	PROCEDURES
	D	W	M	A	H		
1				*		Boom Head (Service)	Drain and service boom head assembly by removing drain plugs and servicing plugs from sidecover. Reinstall drain plugs and service in accordance with instructions on lubrication plate. Install servicing plug. Service boom head assembly in accordance with Task 2-18.
2	*					Boom Head Assembly	Visually inspect for cracks, leaks, dents, corrosion. Check for freedom of movement by rotating boom head assembly against the stops. Inspect identification and lubrication plates for legibility and security of attachment. Inspect harness assembly for cuts, tears, fraying and broken insulation. Inspection shall be in accordance with Task 2-17.

Table 3-1. Intermediate Preventive Maintenance Checks and Services (cont)

ITEM NO.	INTERVAL					ITEM TO BE INSPECTED	PROCEDURES
	D	W	M	A	H		
3		*				Actuator Assembly	Check adjustment of upper limit actuator assembly by measuring the distance between top of actuator and cable guide. Dimension should be 0.75 inch (1.91 cm). Press up on actuator arm until switches are engaged. Measure the distance between the top of arm and cable guide. Dimension should be 0.44 inch (1.18 cm). Adjust actuator assembly in accordance with Task 2-24.
4	*					Cable Cutter	<p style="text-align: center;">NOTE</p> <p>If the cable cutter has been activated, repair the cable cutter in accordance with Task 2-22A.</p> <p>Visually inspect electrical connector for bent, broken and missing pins. Inspect cable for frayed and broken insulation. Check for cuts and tears. Check expiration data of cartridge.</p>
5					50	Pressure Roller	Attach spring scale to pressure roller assembly and check for a minimum tension of 35 pounds. Remove springs and check roller for smooth operation. Refer to Task 3-15 for replacement of pressure roller assembly.
6					50	Cable Cutter	Connect a 28 volt dc light to cable cutter cable connector at boom head. Operate CABLE CUT switch at the operator and pilot position. Verify that the light illuminates.
7		*				Winch Assembly	Visually inspect for nicks, cracks, corrosion and evidence of leakage. Inspect identification and lubrication plates for legibility and security of attachment. Inspect electrical wiring for frayed or broken insulation. Inspect electrical connector for bent, broken or missing pins. Inspect mounting hardware for security. Inspection shall be in accordance with Task 2-22A.

TABLE 3-1. INTERMEDIATE PREVENTIVE MAINTENANCE CHECKS AND SERVICES (cont)

ITEM NO.	INTERVAL					ITEM TO BE INSPECTED	PROCEDURES
	D	W	M	A	H		
8				*		Winch Assembly Service	<p>Drain and service winch assembly by removing drain and breather plugs from winch assembly. Reinstall drain plugs and service in accordance with lubrication instructions. Install breather plug. Service winch assembly in accordance with Task 2-45.</p>
9	*					Hook Assembly	<p>Visually inspect for nicks, cuts, dents or corrosion. Inspect keeper for smooth operation, free of binding or sticking. Ensure cable hook is securely attached to hoist cable. Inspection shall be in accordance with Task 2-56.</p>
10	*					Cable Assembly	<p>Clean the length of the cable used during the last operation, using a clean heavy lint free cloth. Hold cloth firmly around cable, which shall aid in the removal of foreign particles and in detection of broken wires. Simultaneously check cable for kinks, bird caging abrasions and flat spots, as follows:</p> <p>Kinks are caused by a loop in the cable being pulled up tight, resulting in a sharp permanent bend.</p> <p>Bird caging is stretching or untwisting of the outer wraps of wire strands.</p> <p>Flat spots on outer wire strands are evidence of cable misrouting or misalignment. Align winch drum in accordance with Task 2-64.</p> <p>Localized worn sections or abrasions on outer wire strands are evidence of an improperly aligned or defective winch drum. Align winch drum in accordance with Task 2-64.</p>

TABLE 3-1. INTERMEDIATE PREVENTIVE MAINTENANCE CHECKS AND SERVICES (cont)

ITEM NO.	INTERVAL					ITEM TO BE INSPECTED	PROCEDURES
	D	W	M	A	H		
10 (cont)	•						Broken wires, strands, bird caging, kinks or flat spots are cause for cable replacement. Replace cable in accordance with Task 2-60.
11				•		Motor Assembly	Visually inspect for evidence of overheating or shorting. Check electrical comector for bent, broken or tissing pins. Check electrical wiring for frayed or broken insulation. Check motor installation for security. Inspection shall be in accordance with Task 2-49.
12		•				Boot Assembly	Visually inspect for cuts, tears or deterioration. Replace in accordance with Task 2-50.
13	•					Limit Switch Drive	Visually inspect for cracks, nicks, corrosion. Check electrical wiring for frayed or broken insulation. Check earns for excessive play. Check sprocket for wear, nicks, burrs and chipped spline teeth. Inspection shall be in accordance with Task 2-53. Check adjustment of switch. Adjust limit switch in accordance with Task 2-54.
14					5 0	Limit Switch	Test limit switch circuit using limit switch tester in accordance with Task 3-39. Check clearance between cam (not cam lobe) and actuator roller. Clearance should be 0.045 inch (0.112 cm). Adjust clearance in accordance with Task 3-38.
15			•			Drum Assy	Refer to the illustration on page 2-127. Remove screws (11) and plate (8). Visually inspect for cracks, dents, nicks. Inspect drum grooves for distortion or abnormalities and uneven wear. Check cable kicker for loose rivits.

Table 3-1. Intermediate Preventive Maintenance Checks and Services (cont)

Item No.	Interval					Item To Be Inspected	Procedures
	D	W	M	A	H		
16			*			Drum Assy	Check alignment of drum assembly by removing pressure cover item (1) on illustration, page 2-126. While reeling in cable, observe cable travel through cable cutter assembly. Cable should not contact cable cutter. If required, align drum assembly in accordance with Task 2-64.
17	*					Control Panel Assy	Visually inspect for cracks, dents, broken power light and security of switches.
18	*					Control Pendant Assy	Visually inspect for cracks or dents. Press to test the serviceability for the temperature and caution light. Check electrical connector for bent, broken or missing pins. Ensure operational switches operate smoothly, free of binding or sticking. Check for stripped, crossed or damaged threads. Inspection shall be in accordance with Task 2-15.
19	*					Control Cable	Visually inspect for cuts, tears, fraying or broken insulation. Check cable connectors for bent, broken or missing pins. Check for crossed, stripped or damaged threads. Inspection shall be in accordance with Task 2-15.
20	*					Cable Umbilical	Visually inspect for cuts, tears, broken or fraying insulations. Check electrical connector for bent, broken or missing pins. Check for evidence of overheating or shorting. Check threaded parts for crossed, stripped or damaged threads. Inspection shall be in accordance with Task 2-65.

TABLE 3-1. INTERMEDIATE PREVENTIVE MAINTENANCE CHECKS AND SERVICES (cont)

ITEM No.	INTERVAL					ITEM TO BE INSPECTED	PROCEDURES
	D	W	M	A	H		
21	*					Boom Position Support Assembly	Visually inspect for cracks, loose mounting hardware and corrosion. Check for dents on the stanchion tube, upper and lower support and switch cover. Check aircraft position plate for legibility and security of attachment. Inspect hook and pendant spring for damage. Inspection shall be in accordance with Task 2-28.
22		*				Height Adjuster	Visually inspect for nicks, cracks, corrosion. Ensure smooth operation, free of binding or sticking. Check plunger locking device by placing plunger in locked position and attempt to rotate height adjuster.
23	*					Quick Disconnect	Check upper and lower quick disconnectors for corrosion and cracks. Check locking action of jaw when placed in the closed position. Inspection shall be in accordance with Tasks 2-34, 2-42.

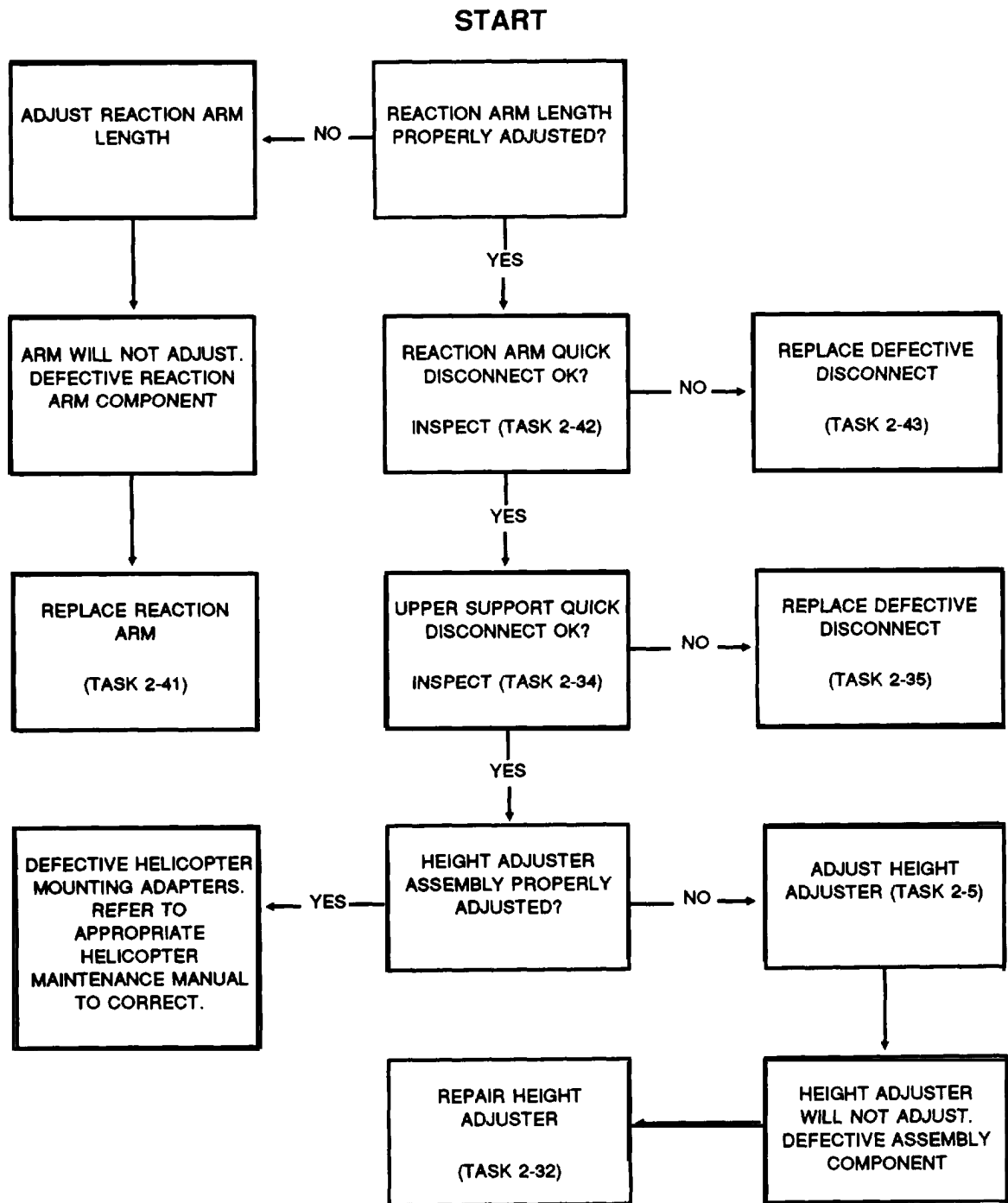
Section IV. TROUBLESHOOTING

3-10. Troubleshooting. If malfunction or failure occurs during operation or performance check, perform troubleshooting in accordance with logic tree diagrams. Refer to table 3-2, Symptom Index, for determining applicable troubleshooting procedure.

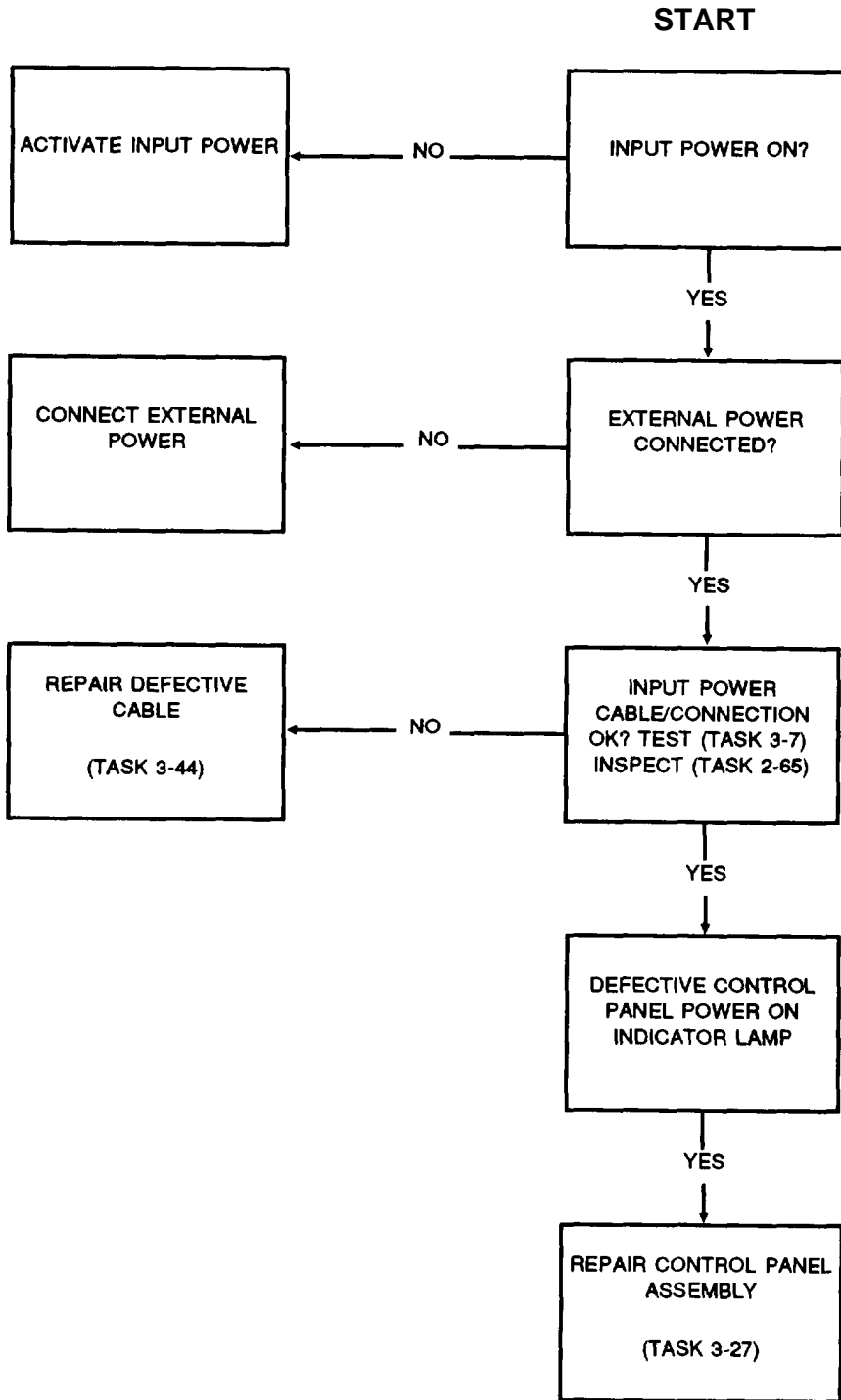
Table 3-2. SYMPTOM INDEX

Symptom	Troubleshooting Procedure
Boom Head Assembly	
Does not swing full 205 degrees	4
Inoperative	3
Overheats	14
Brake	
No positive brake action	11
Positive action deceleration inoperative	6
Control Panel	
Operating switch inoperative	18
Pilots override control inoperative	17
Control Pendant	
Intercom inoperative	16
Operating switch inoperative	18
Hoist Cable	
Does not reel smoothly	10
Lamps/Indicators	
Caution lamp inoperative	7
Temp warning lamp inoperative	15
Rescue Hoist	
Hoist does not install properly	1
Inoperative	2
Winch Assembly	
Cable speed-less than 100 RPM	8
Cable speed-exceeds 15 RPM	9
Hoist cable does not reel smoothly	10
Inoperative	5
Overheats	13
Winch motor overheats	12

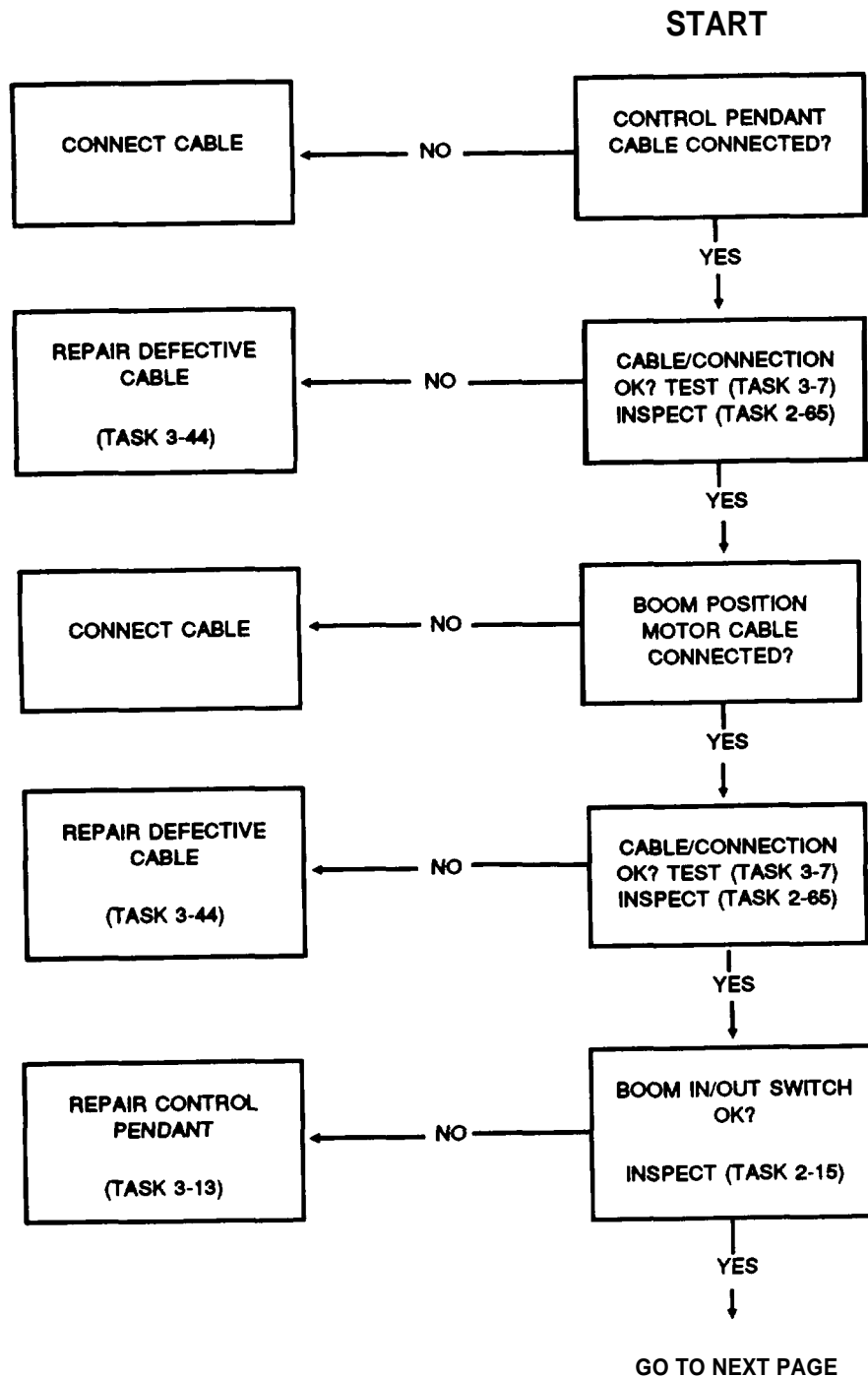
TROUBLESHOOTING PROCEDURE 1. RESCUE HOIST DOES NOT INSTALL PROPERLY



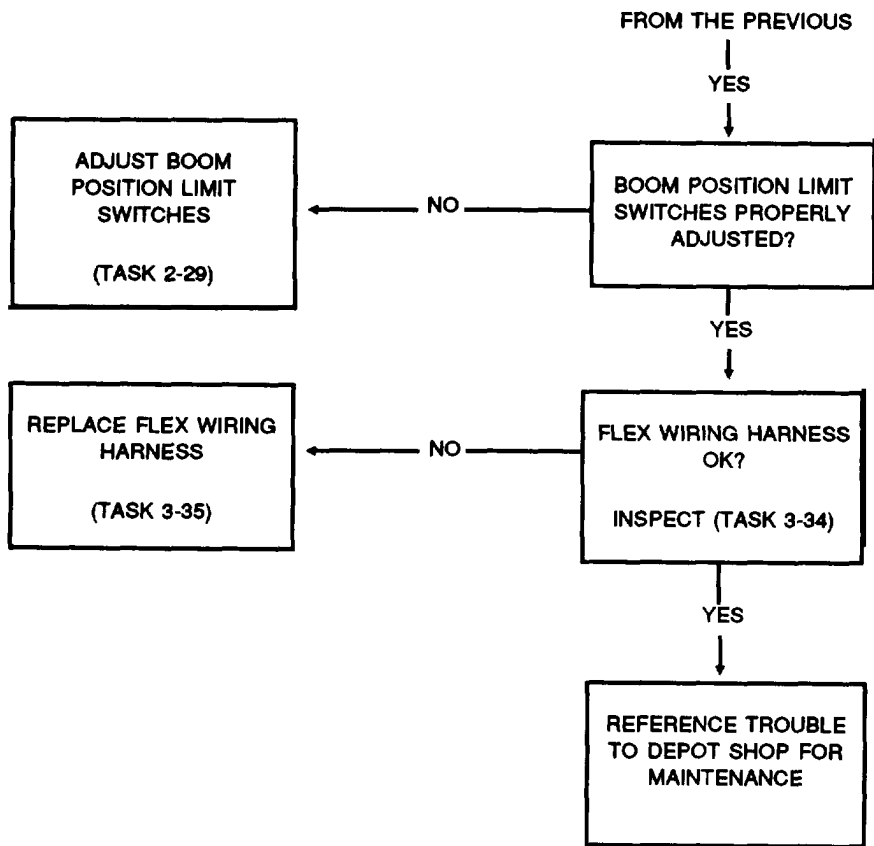
TROUBLESHOOTING PROCEDURE 2. RESCUE HOIST INOPERATIVE, CONTROL PANEL POWER ON INDICATOR DOES NOT ILLUMINATE



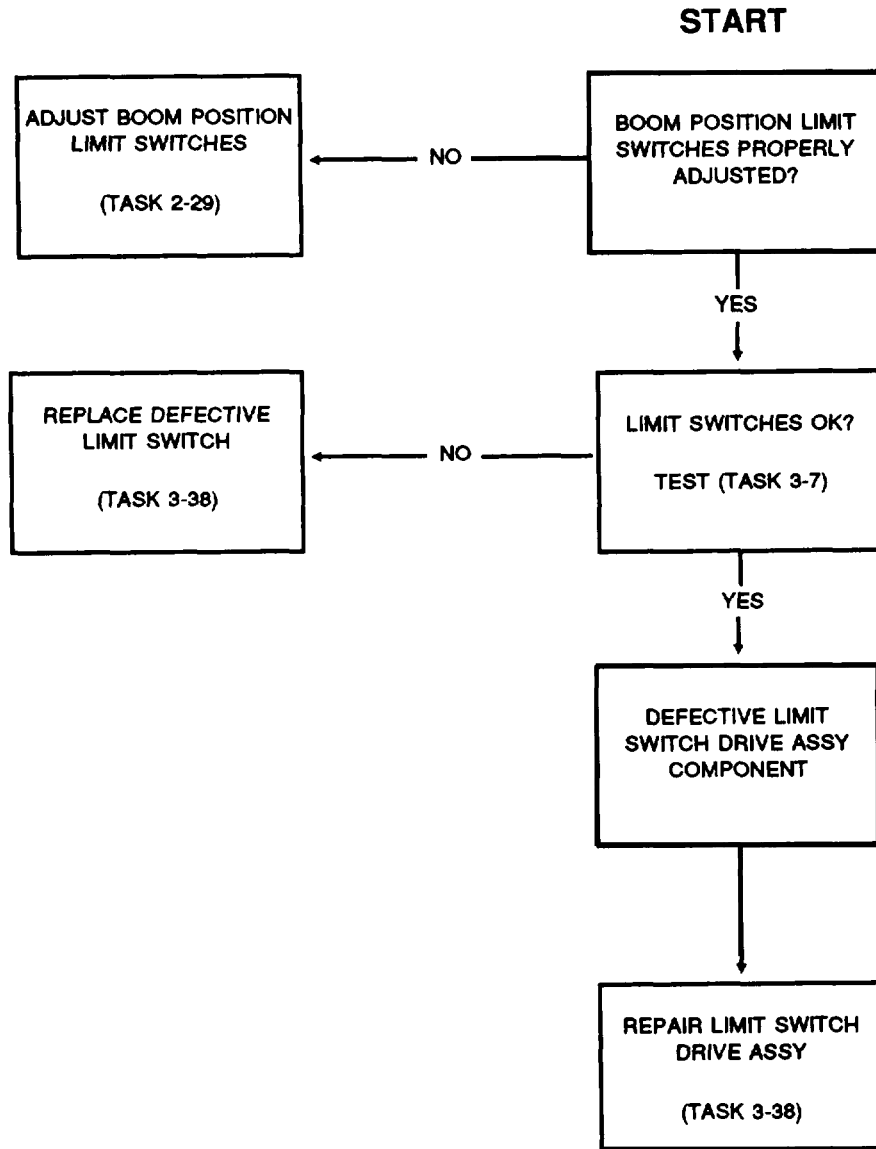
TROUBLESHOOTING PROCEDURE 3. HOIST BOOM INOPERATIVE, BOOM IN/OUT SWITCH ACTIVATED



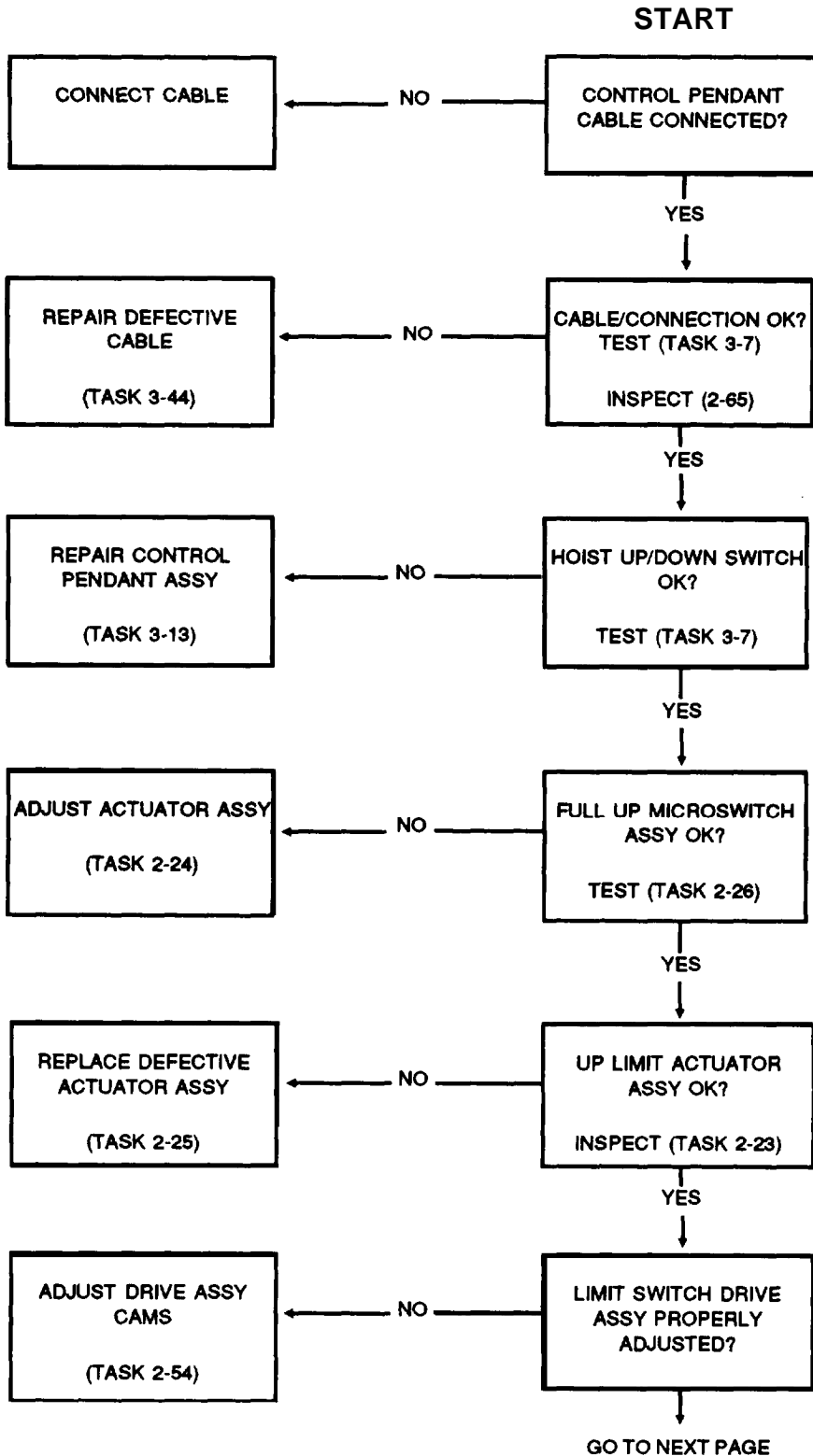
TROUBLESHOOTING PROCEDURE 3. (CONT) HOIST BOOM INOPERATIVE, BOOM IN/OUT SWITCH ACTIVATED



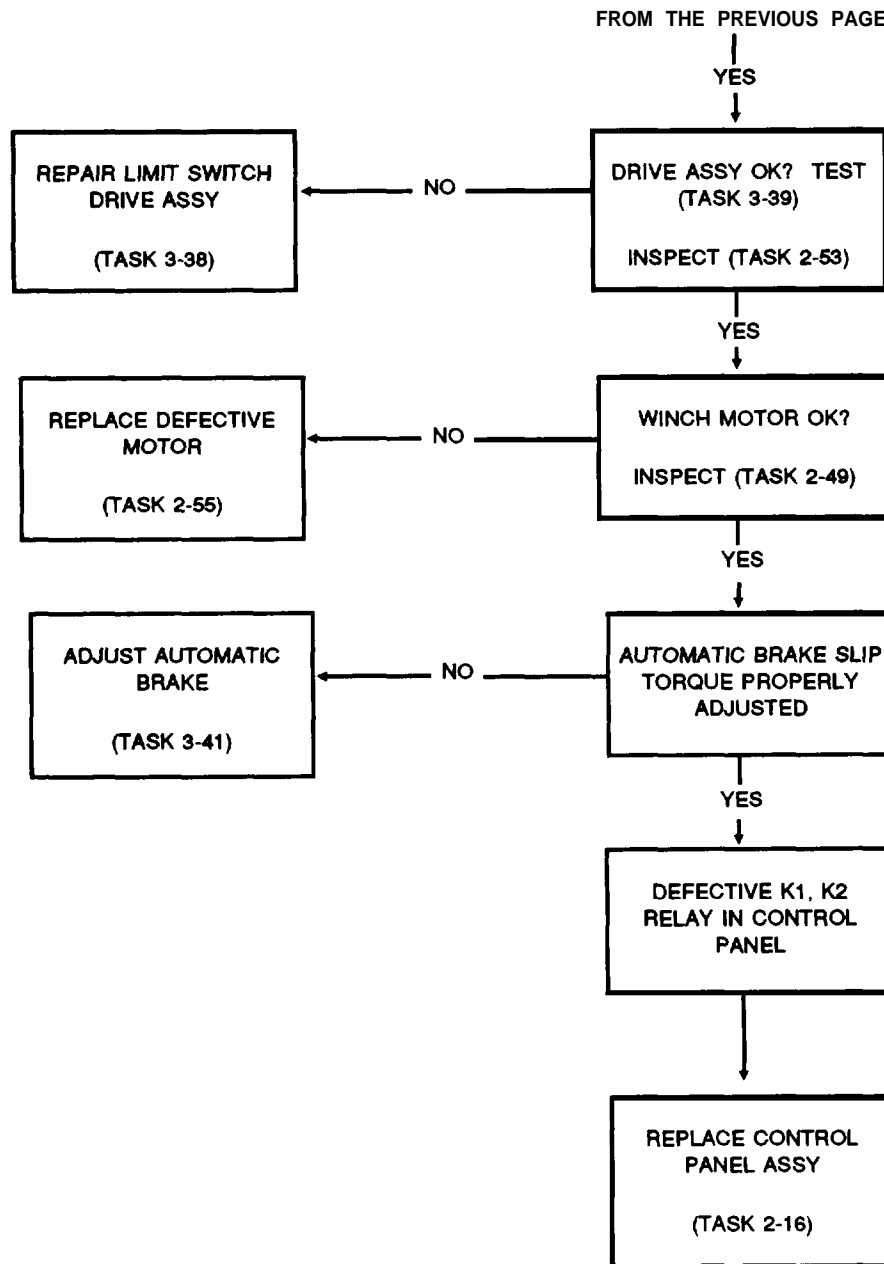
TROUBLESHOOTING PROCEDURE 4. HOIST BOOM DOES NOT SWING FULL 205 DEGREES



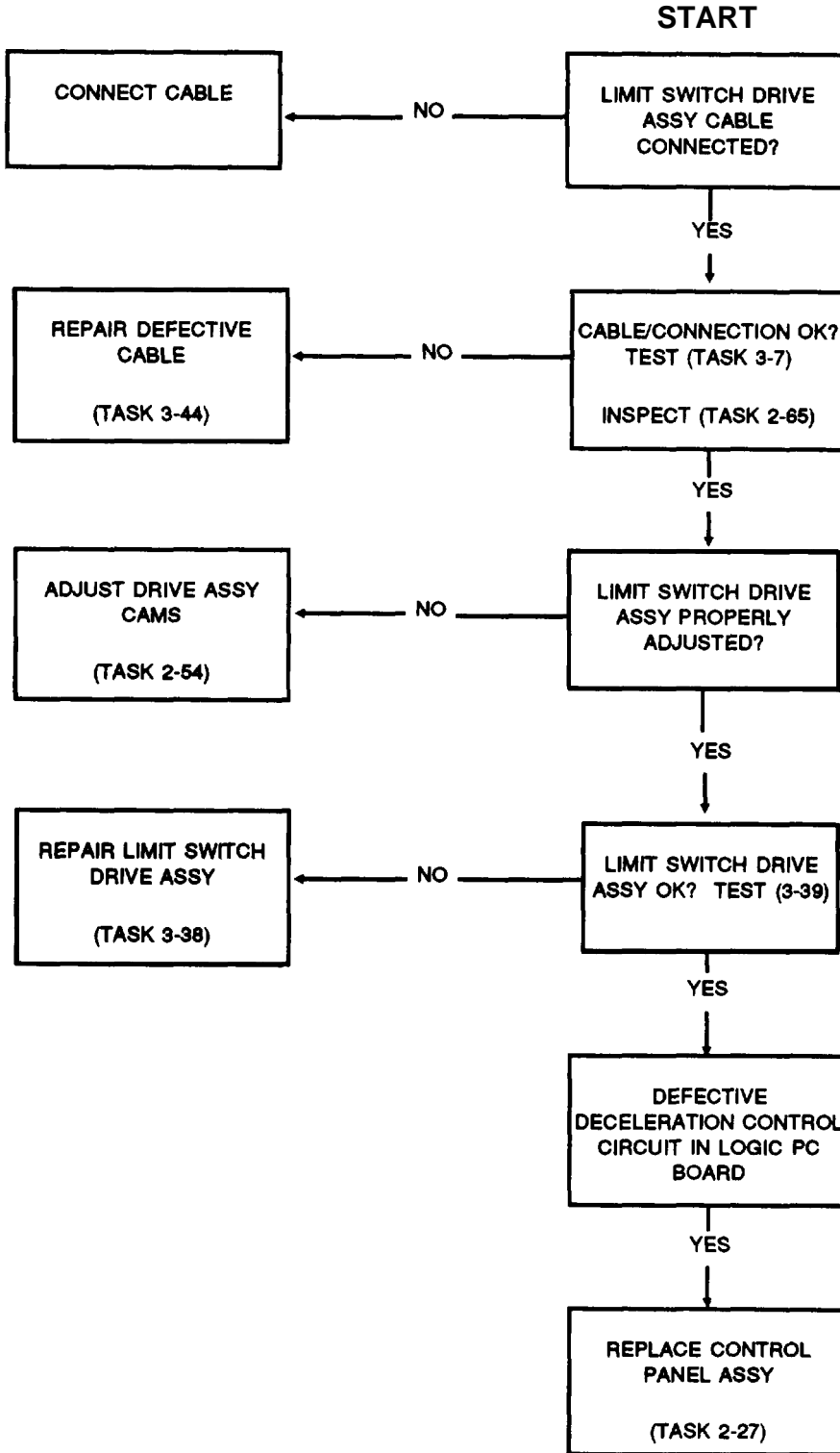
TROUBLESHOOTING PROCEDURE 5. HOIST WINCH INOPERATIVE, HOIST UP/DOWN SWITCH ACTIVATED



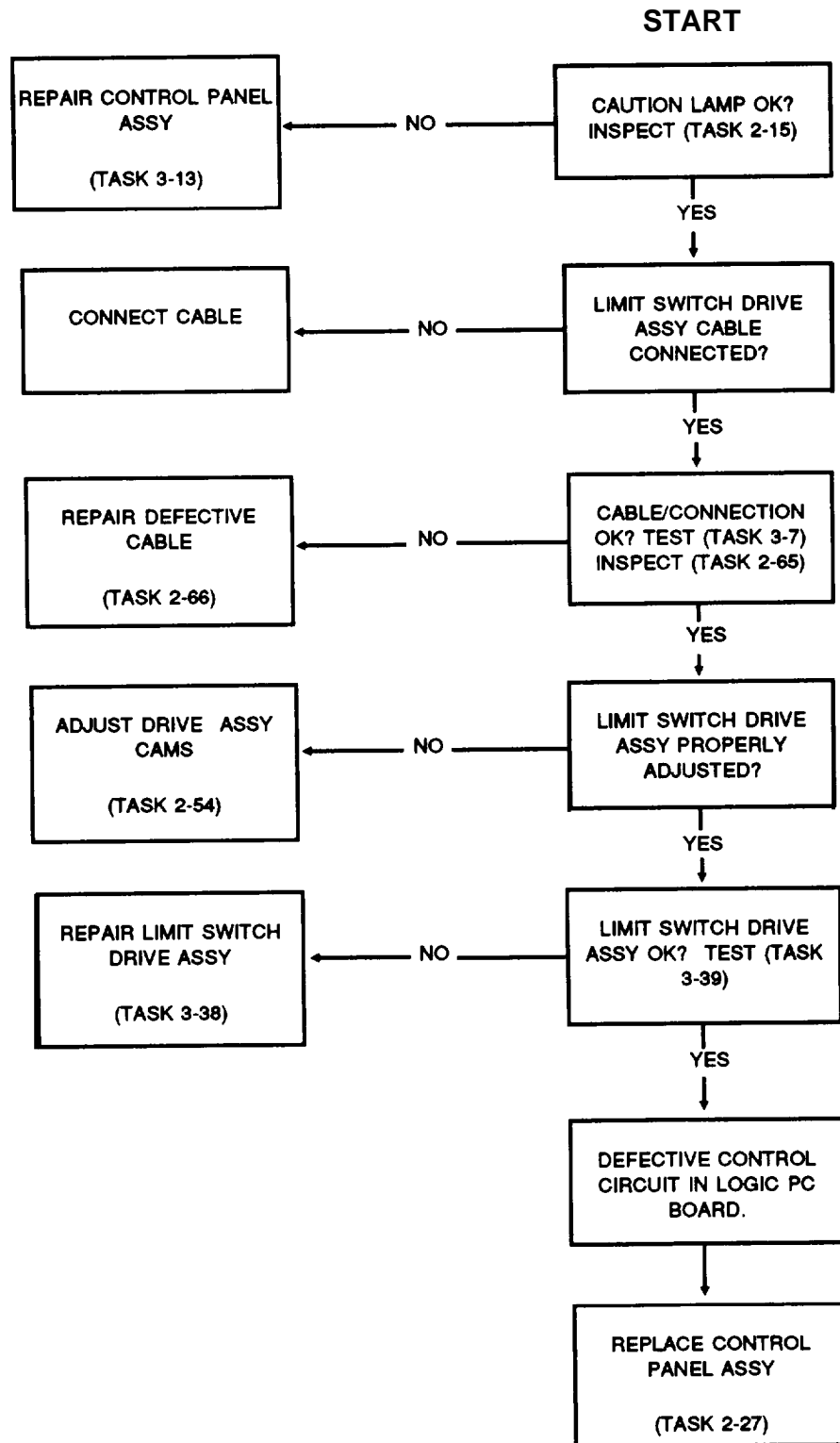
TROUBLESHOOTING PROCEDURE 5. (CONT) HOIST WINCH INOPERATIVE, HOIST UP/DOWN SWITCH ACTIVATED



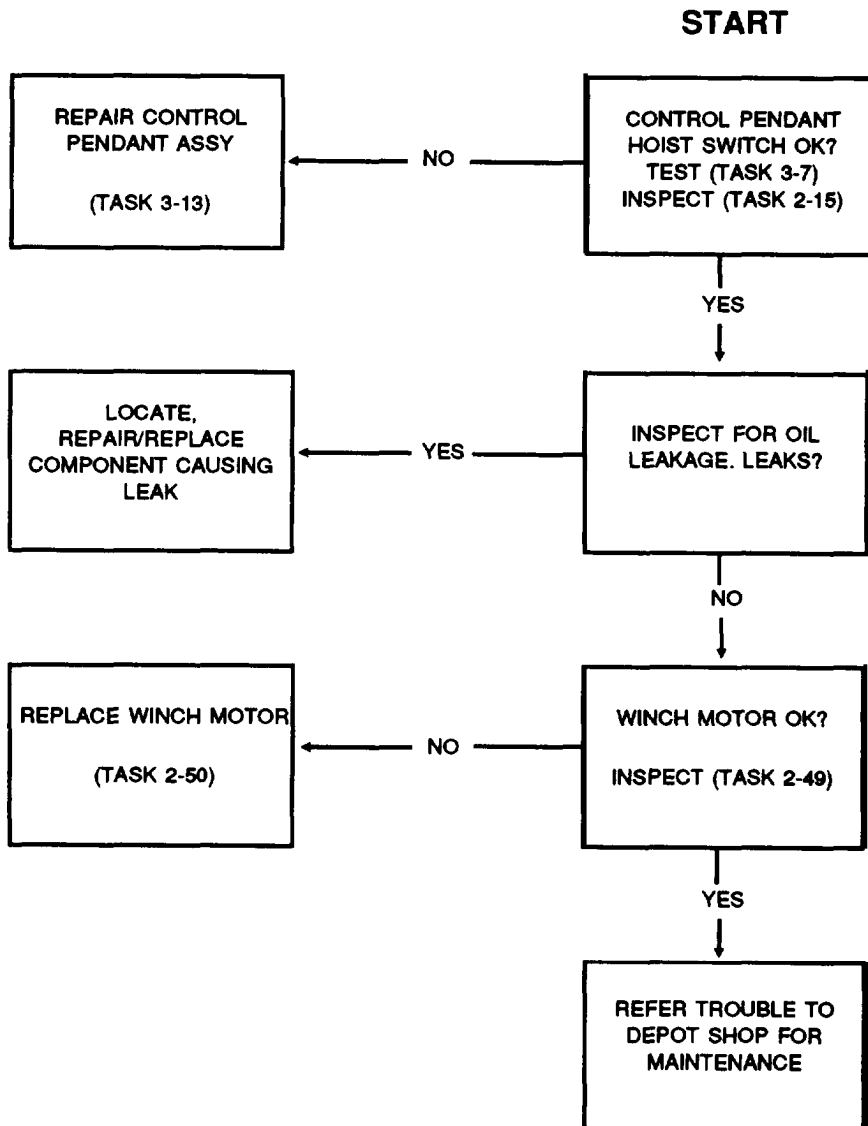
TROUBLESHOOTING PROCEDURE 6. NO POSITIVE ACTION DECELERATION. HOOK WITHIN 3 FEET OF DOWN-STOP LIMIT (EXTENSION) OR 1 FOOT FROM FULL STOW (REEL IN)



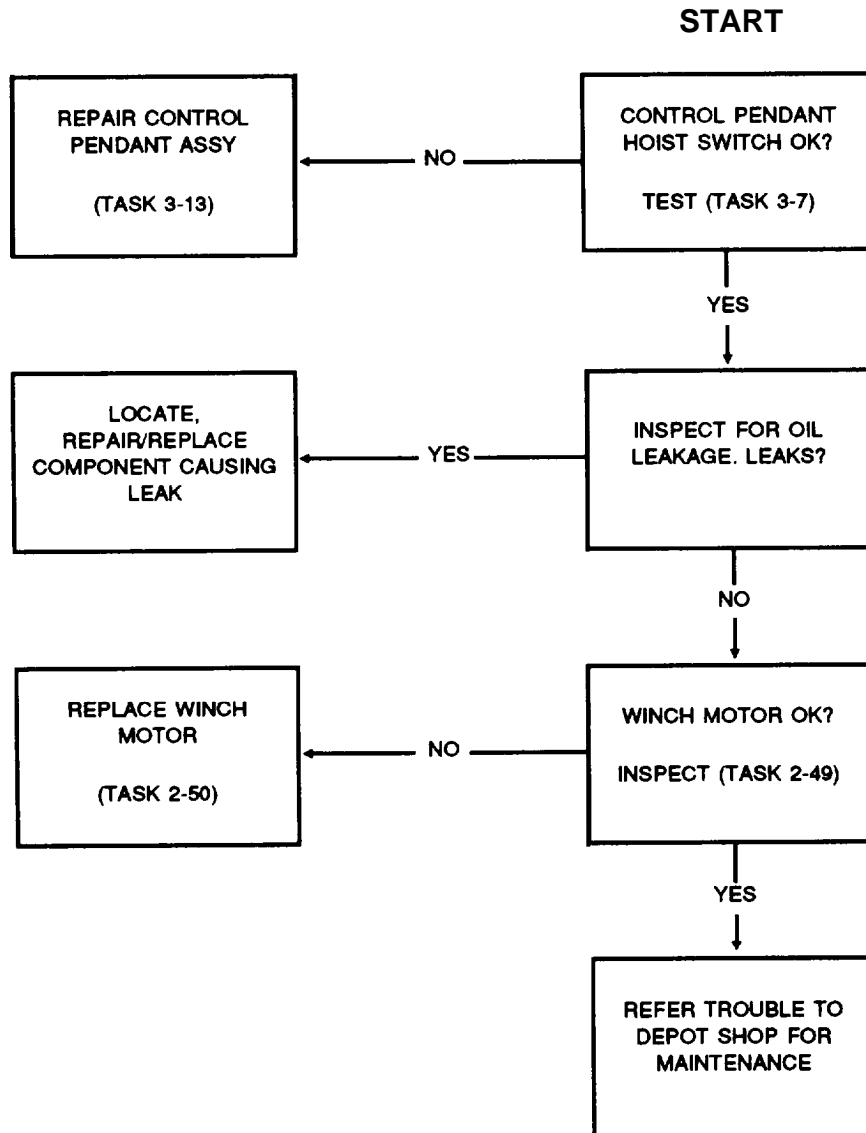
TROUBLESHOOTING PROCEDURE 7. CAUTION LAMP DOES NOT ILLUMINATE. CABLE HOOK WITHIN 8-10 FEET OF FULL STOW



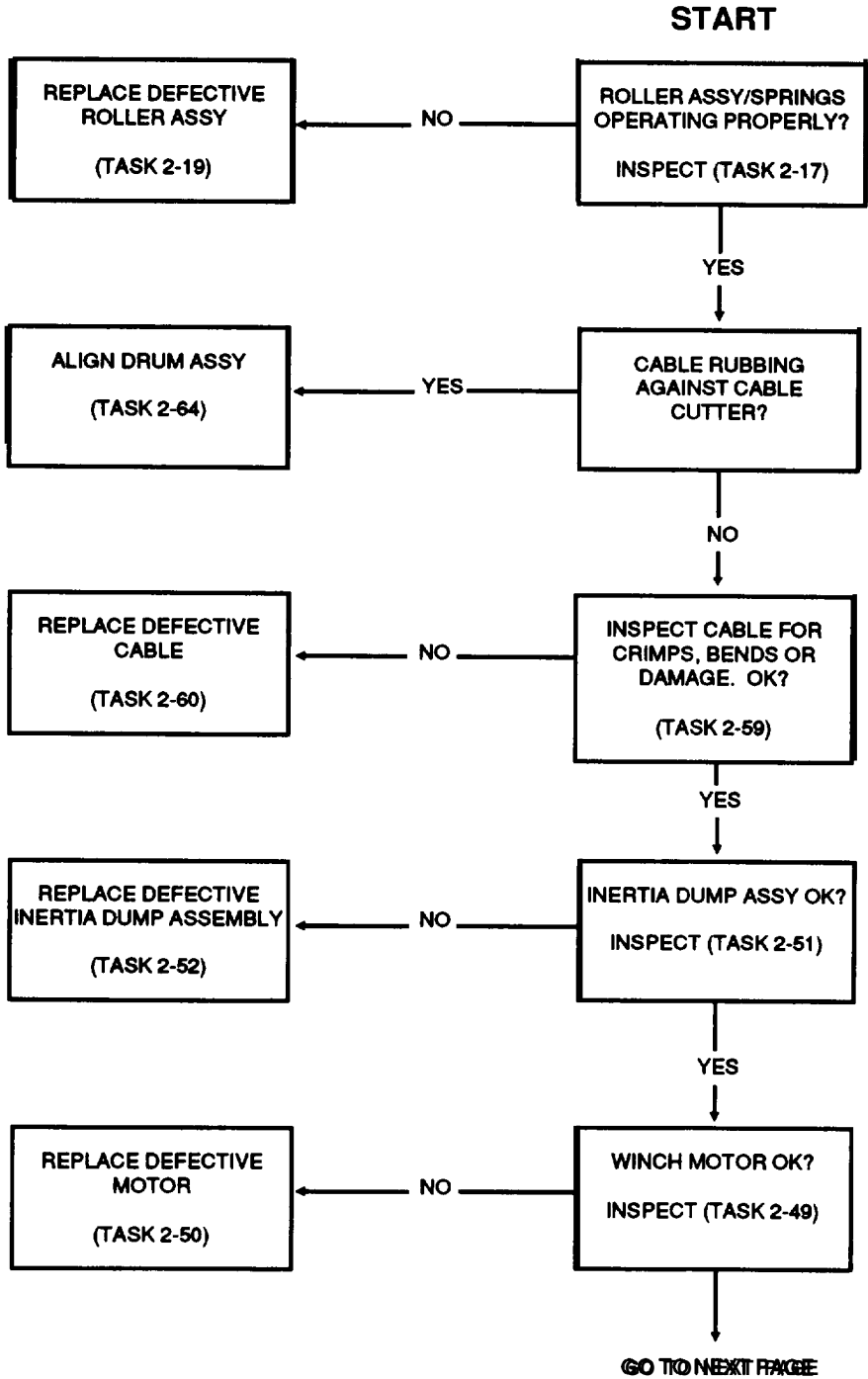
**TROUBLESHOOTING PROCEDURE 8. CABLE SPEED LESS THAN 100 RPM,
HOIST OPERATED AT MAXIMUM**



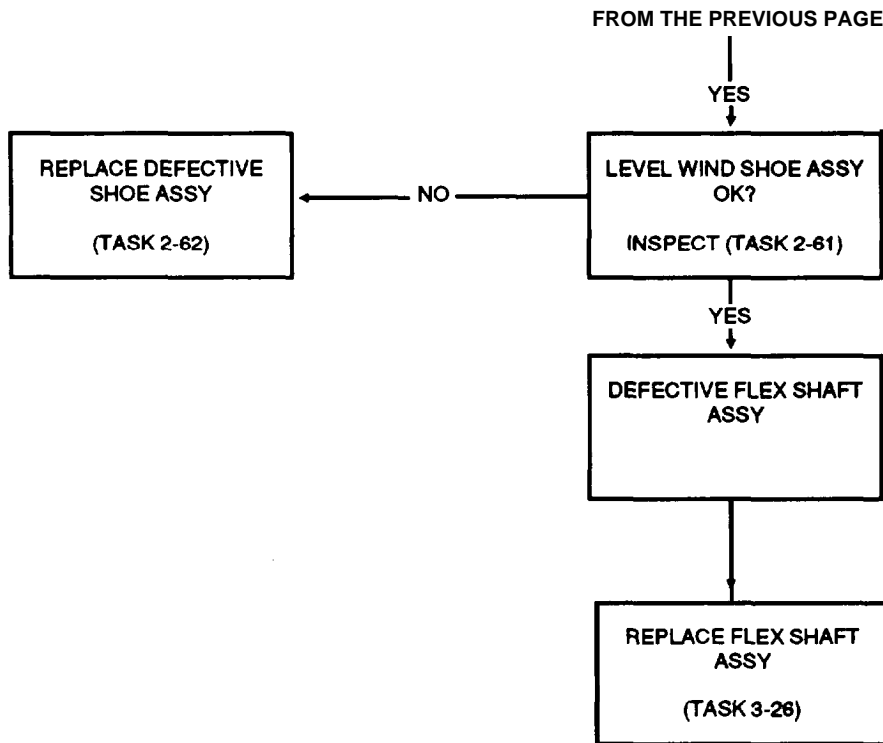
TROUBLESHOOTING PROCEDURE 9. CABLE SPEED EXCEEDS 15 RPM, HOIST OPERATED AT MINIMUM



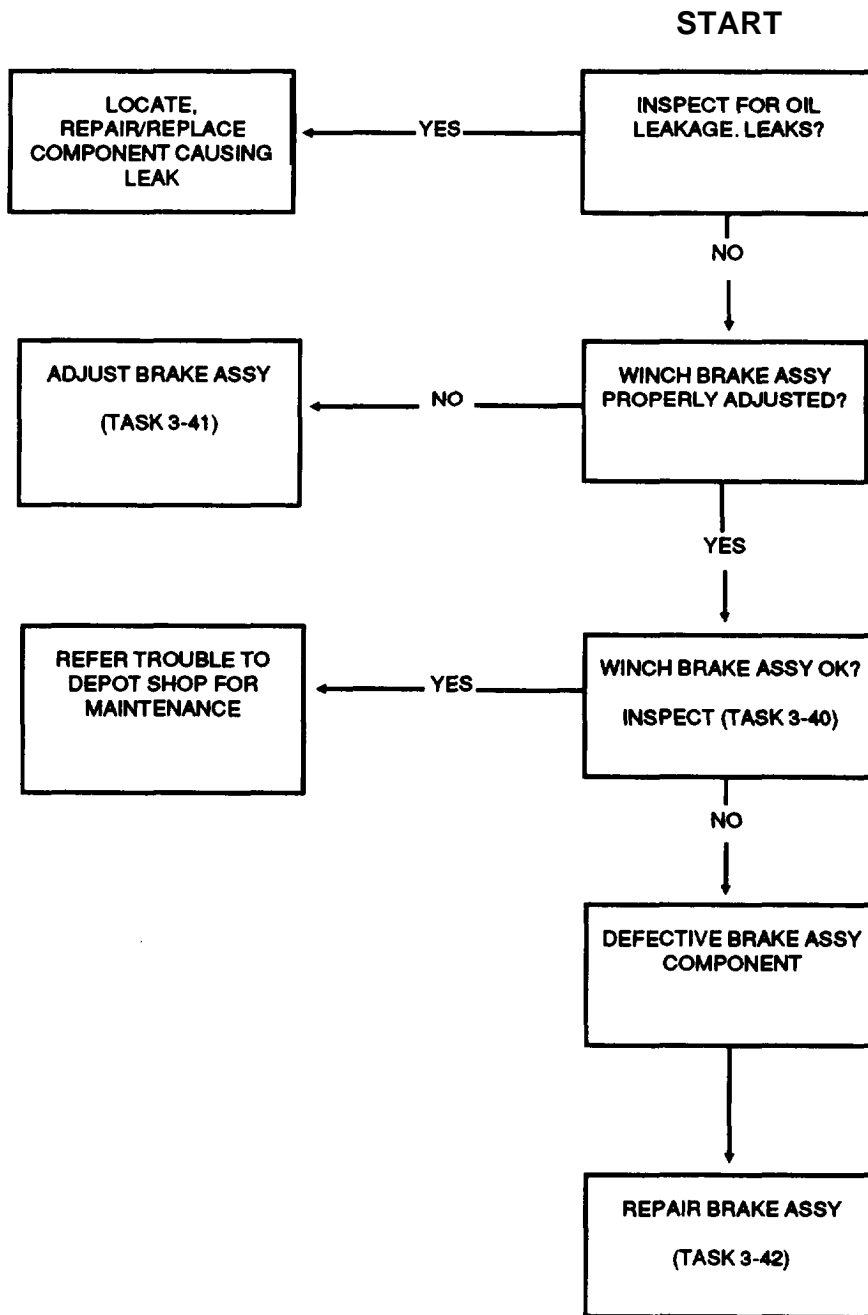
TROUBLESHOOTING PROCEDURE 10. HOIST CABLE DOES NOT REEL SMOOTHLY



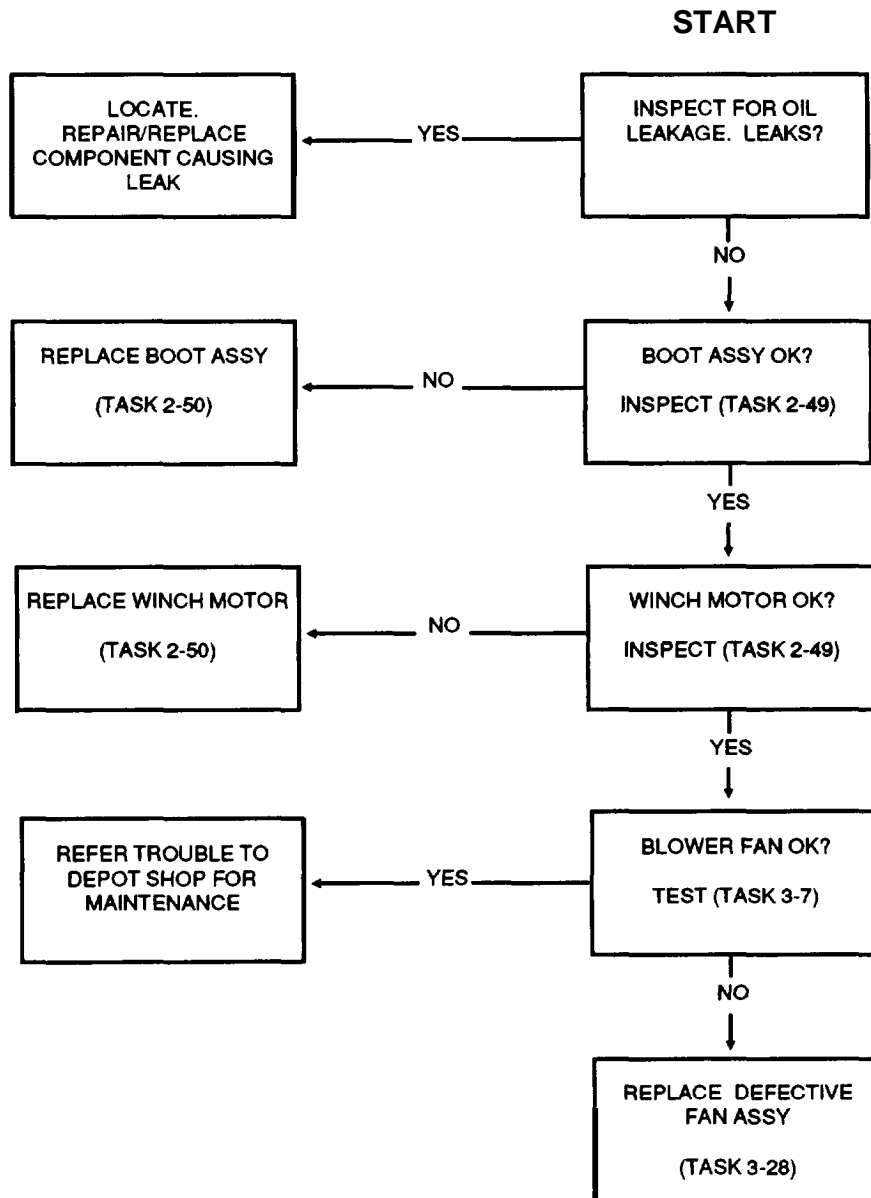
TROUBLESHOOTING PROCEDURE 10. (CONT) HOIST CABLE DOES NOT REEL SMOOTHLY



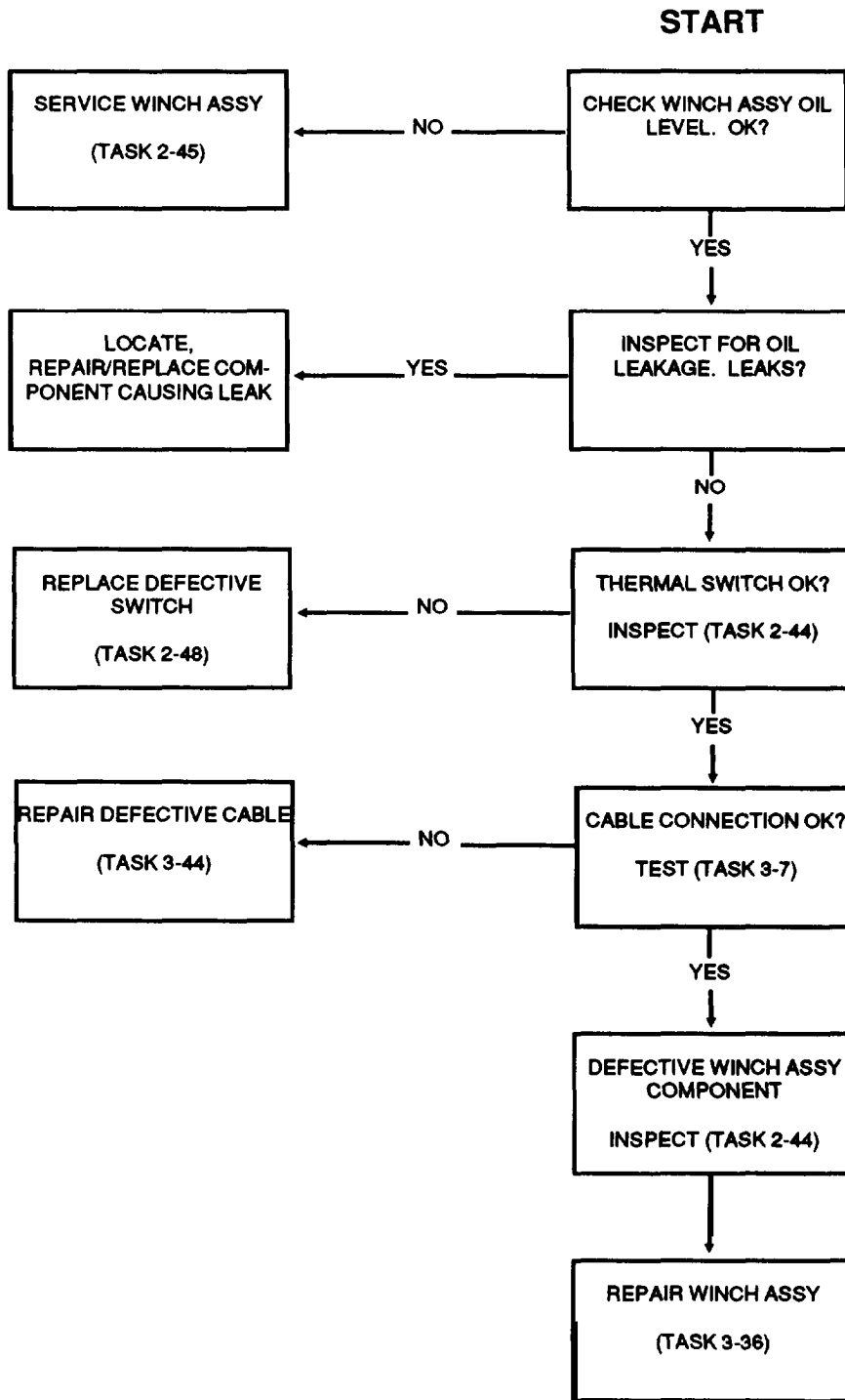
TROUBLESHOOTING PROCEDURE 11. NO POSITIVE BRAKE ACTION



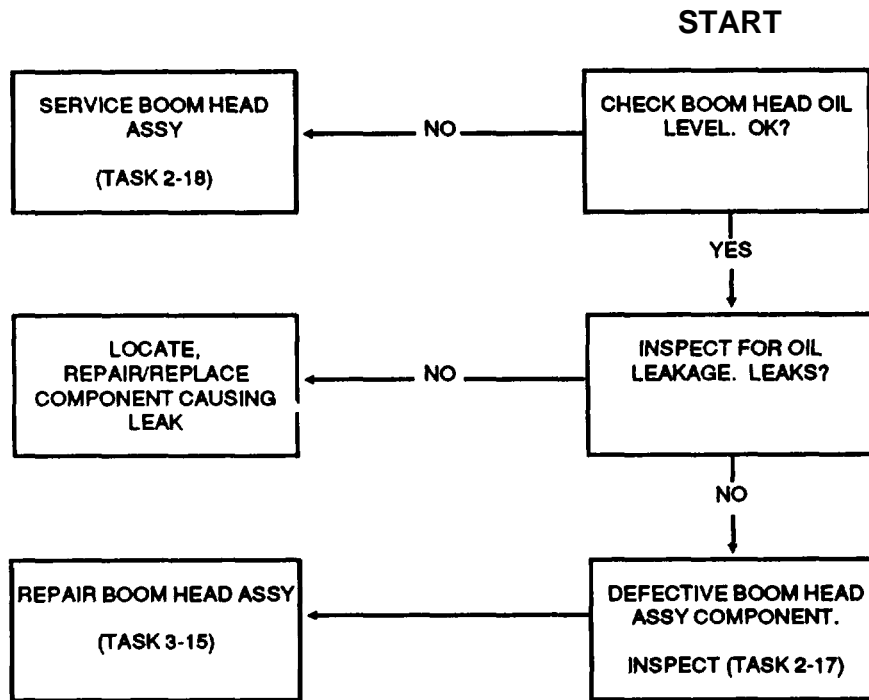
TROUBLESHOOTING PROCEDURE 12. ELECTRIC WINCH MOTOR OVERHEATS



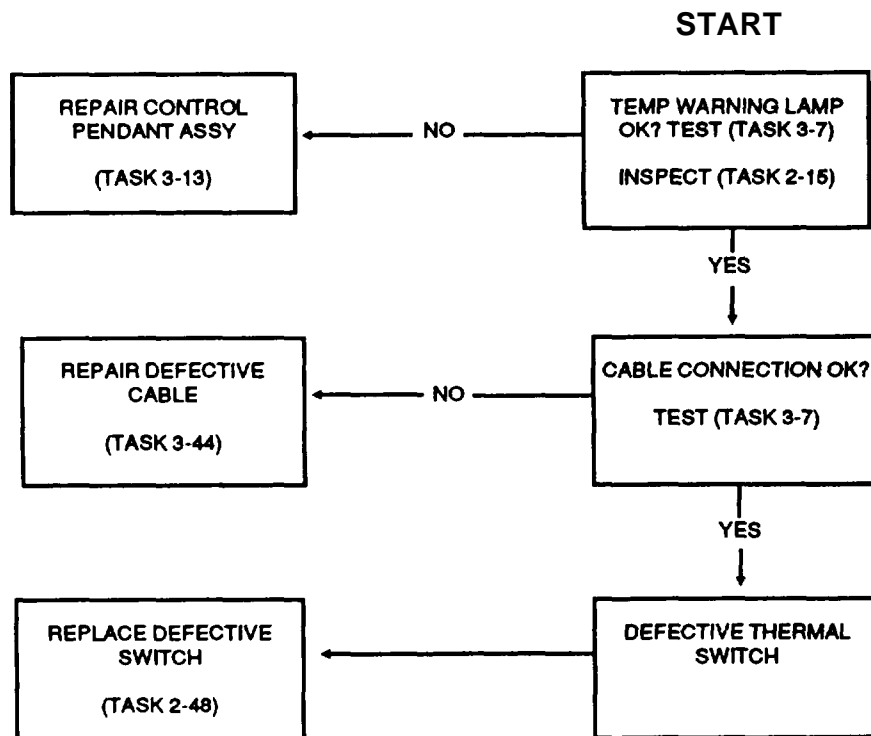
TROUBLESHOOTING PROCEDURE 13. WINCH ASSY OVERHEATS



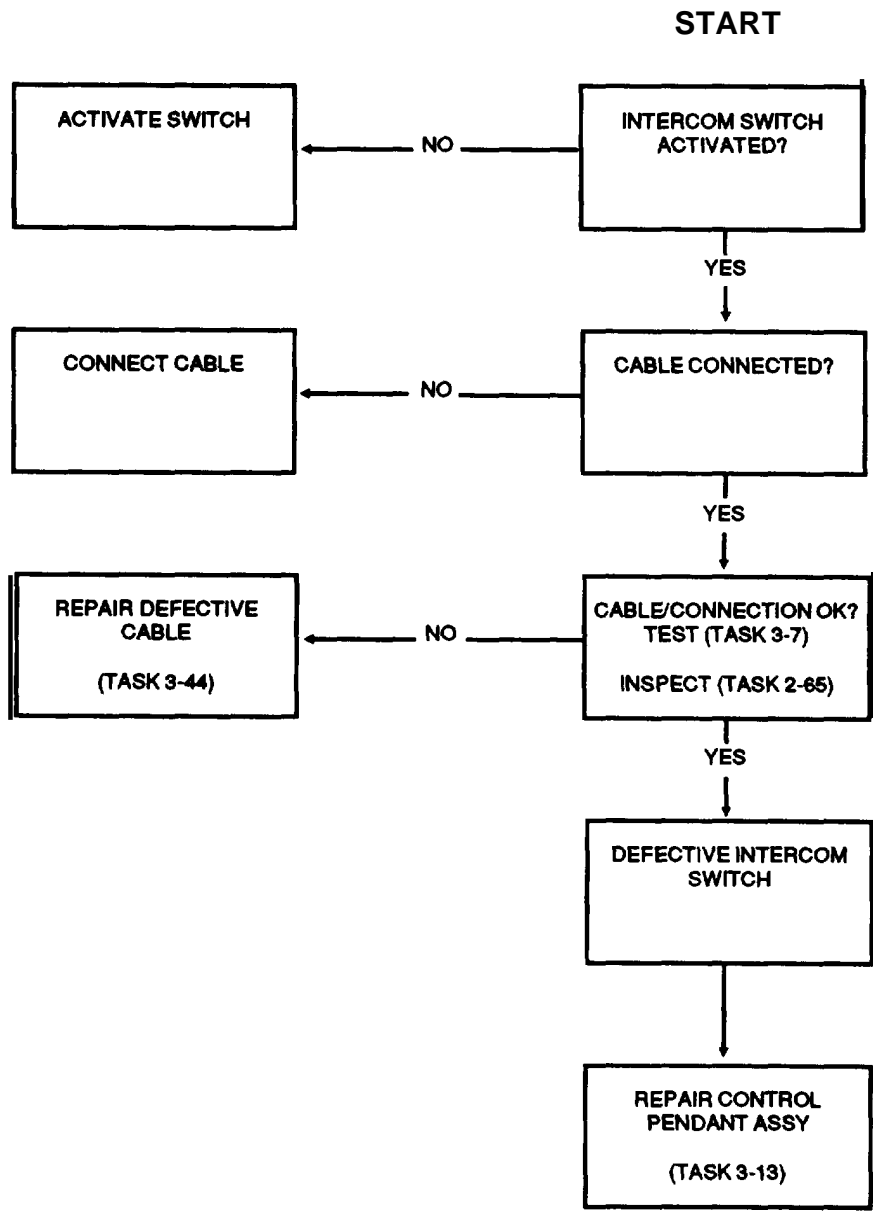
TROUBLESHOOTING PROCEDURE 14. BOOM HEAD ASSY OVERHEATS



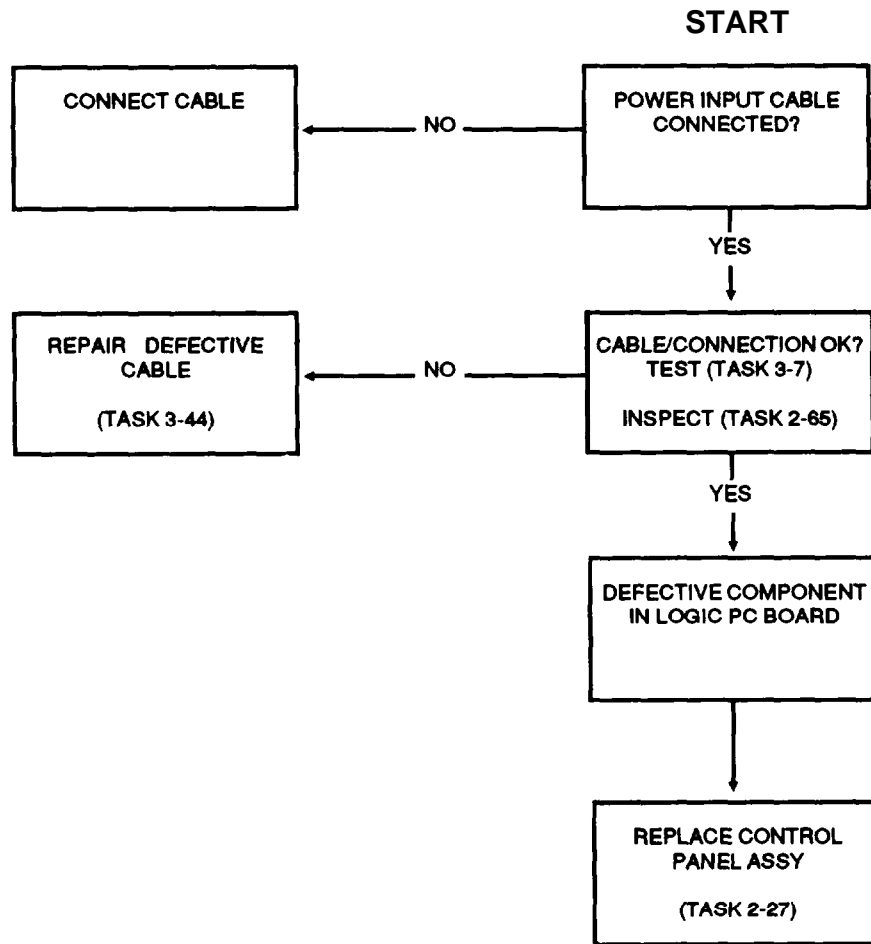
TROUBLESHOOTING PROCEDURE 15. TEMP WARNING LAMP DOES NOT ILLUMINATE, COMPONENT OVERHEATING



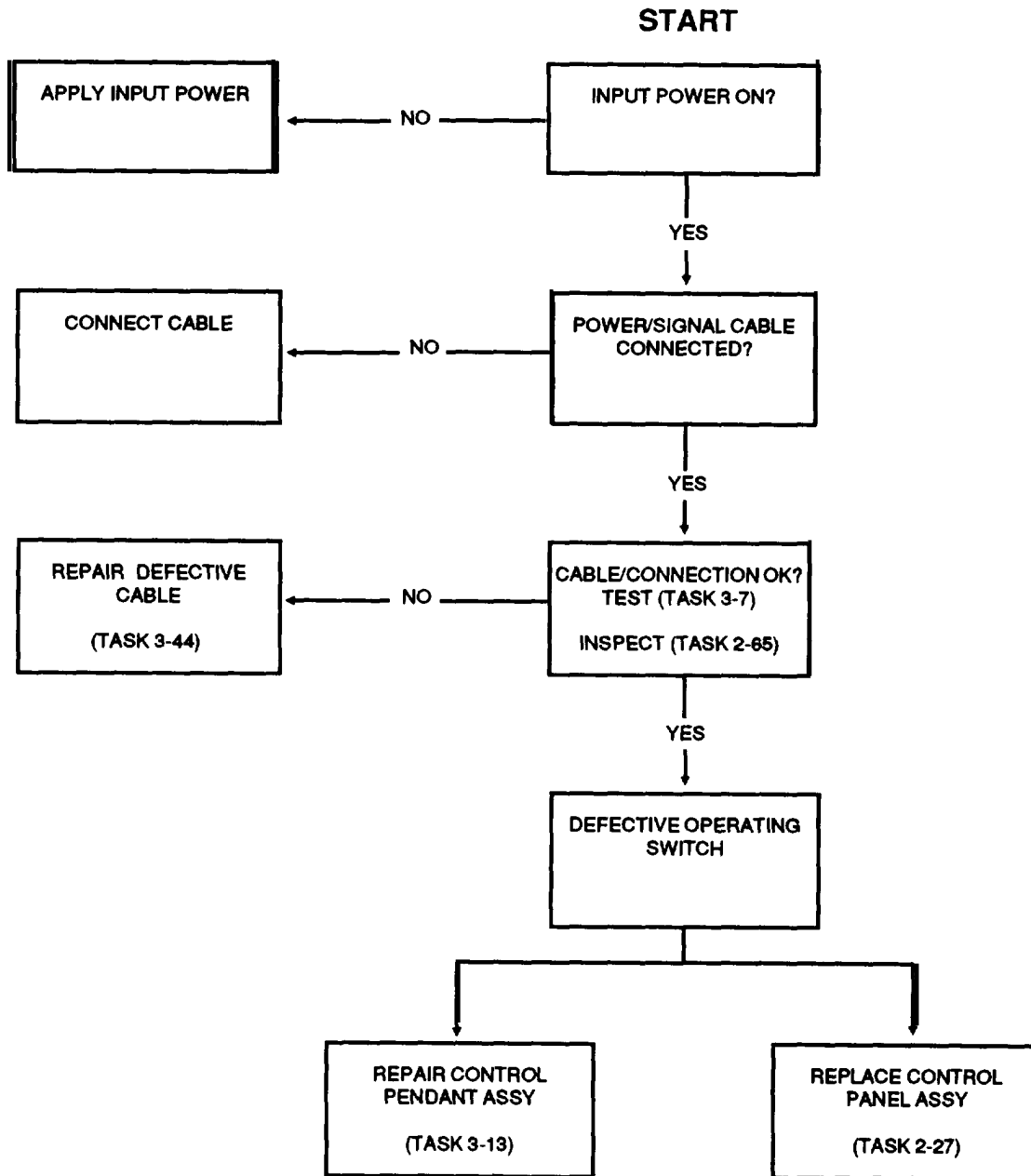
TROUBLESHOOTING PROCEDURE 16. INTERCOM INOPERATIVE



**TROUBLESHOOTING PROCEDURE 17. PILOTS OVERRIDE CONTROLS
INOPERATIVE**



TROUBLESHOOTING PROCEDURE 18. OPERATING CONTROL SWITCH INOPERATIVE



Section V. MAINTENANCE PROCEDURES

3-11. RESCUE HOIST - ADJUST

3-11

This task covers: Adjustment

INITIAL SETUP

Personnel Required:

67N, UH1 Helicopter Repairer
67T, UH60 Helicopter Repairer
91W, Medevac Medics

Equipment Condition:

Hoist installed in helicopter

Parts/Materials:

Cleaning Solvent (Item 10, App.D)
Lockwire (Item 18, App.D)

Equipment Condition Para:

Task 3-5

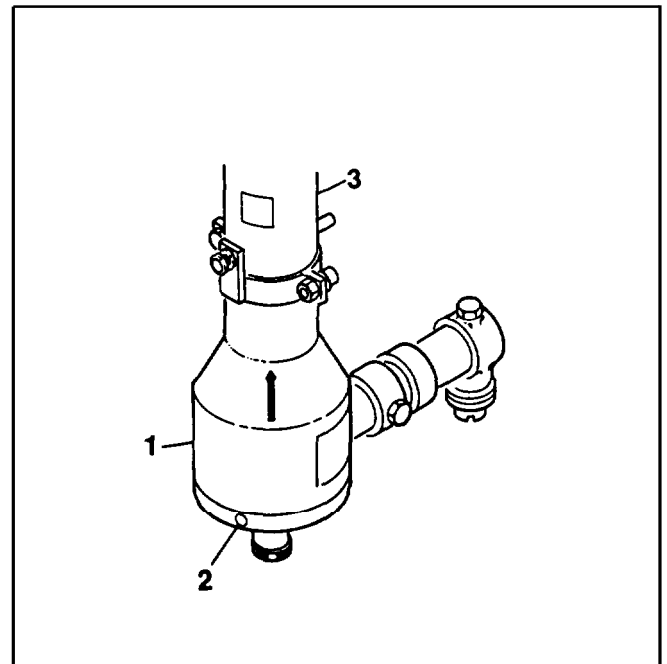
Tools and Test Equipment:

Tool Kit, Aircraft Mechanics
NSN 5180-00-323-4692
Shop Set, Intermediate Maintenance
NSN 4920-00-472-4183
Multimeter

References:

None

1. Adjust limit switch drive assembly in accordance with Task 2-54.
2. Adjust actuator assembly (up-limit) switch in accordance with Task 2-24.
3. Adjust boom position support assembly in accordance with task 2-29.
4. Adjust boom position actuator overtorque limit switches as follows:
 - a. Ensure AIRCRAFT POSITION switch is in position 1-3 and boom position actuators locked in position 1.
 - b. Release base cover (1) by removing screws (2). Slide cover up on stanchion tube (3) to gain access to boom position switches.



GO TO NEXT PAGE

3-11. RESCUE HOIST - ADJUST (cont)

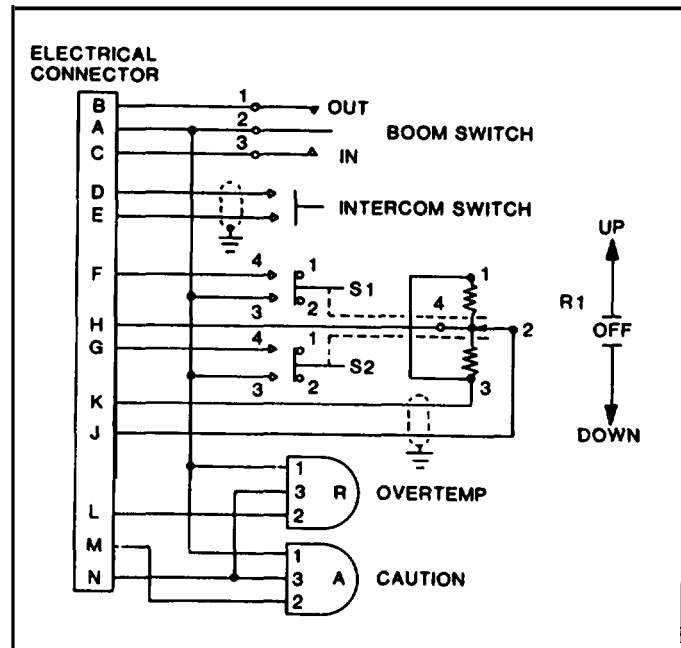
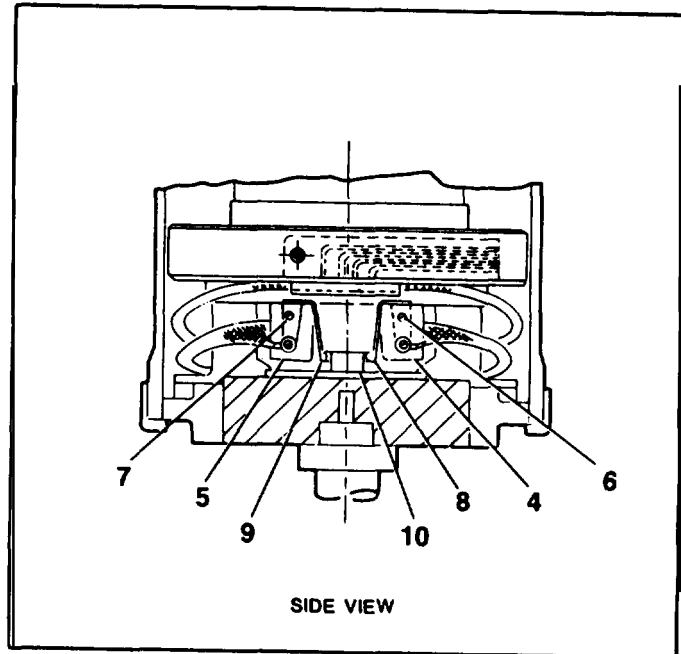
c. If switches S1 or S2 (4, 5) were placed or electrical wiring repaired, check continuity as follows:

- (1) Disconnect electrical plug P5 from connector J5 on control panel assembly.
- (2) Using a multimeter, check continuity between pins A and C on plug P5 while actuating switches S2 and S3 (5, 11).

NOTE

If a fault is detected, replace or repair defective component before continuing.

- (3) Check continuity between pins B and C on plug P5 while actuating switches S1 and S4 (4, 12).
 - (4) Connect electrical plug P5 to connector J5 on control panel.
- d. Loosen screws (6, 7). Adjust switches S1 and S2 (4, 5) and actuators (8, 9) for 0.05 inch (1.27 cm) clearance on each side of actuating lever (10). Tighten screws (6, 7).



GO TO NEXT PAGE

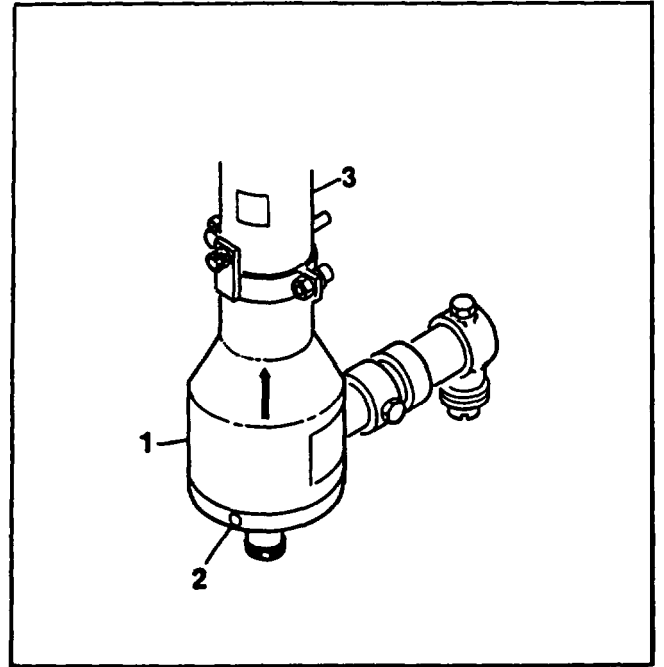
3-11. RESCUE HOIST - ADJUST (cont)

3-11

- e. Slide cover (1) down stanchion tube (3) and position. Install cover using screws (2) and safety wire cover using lockwire.

FOLLOW-ON MAINTENANCE:

None

**END OF TASK**

3-12. RESCUE HOIST - REPAIR**3-12****This task covers: Repair****INITIAL SETUP****Personnel Required:**

67N, UH1 Helicopter Repairer
 67T, UH60 Helicopter Repairer
 91W, Medevac Medics

Equipment Condition:

Hoist installed in assembly stand

Parts/Materials:

None

Equipment Condition Para:

Task 3-5

Tools and Test Equipment:

Tool Kit, Aircraft Mechanics
 NSN 5180-00-323-4692
 Shop Set, Intermediate Maintenance
 NSN 4920-00-472-4183
 Tool Kit, Electrical Repairer
 NSN 5180-00-323-4915
 Multimeter

References:

None

Repair of rescue hoist consists of removal, repair and installation of hoist components. Refer to specific tasks (3-13 thru 3-44) for aviation intermediate maintenance repair.

FOLLOW-ON MAINTENANCE:

None

END OF TASK

3-13. CONTROL PENDANT ASSY - REPAIR

3-13

This task covers: Disassembly, cleaning, inspection, repair and reassembly

INITIAL SETUP**Personnel Required:**

67N, UH1 Helicopter Repairer
67T, UH60 Helicopter Repairer
68F, Aircraft Electrical Repairer
91W, Medevac Medics

Equipment Condition:

Control pendant removed

Parts/Materials:

Adhesive, RTV-103 (Item 4, App. D)
Cleaning **Solvent** (Item 10, App. D)
Lockwire (Item 17, App. D)

Equipment Condition Para:

Task 2-16

Tools and Test Equipment:

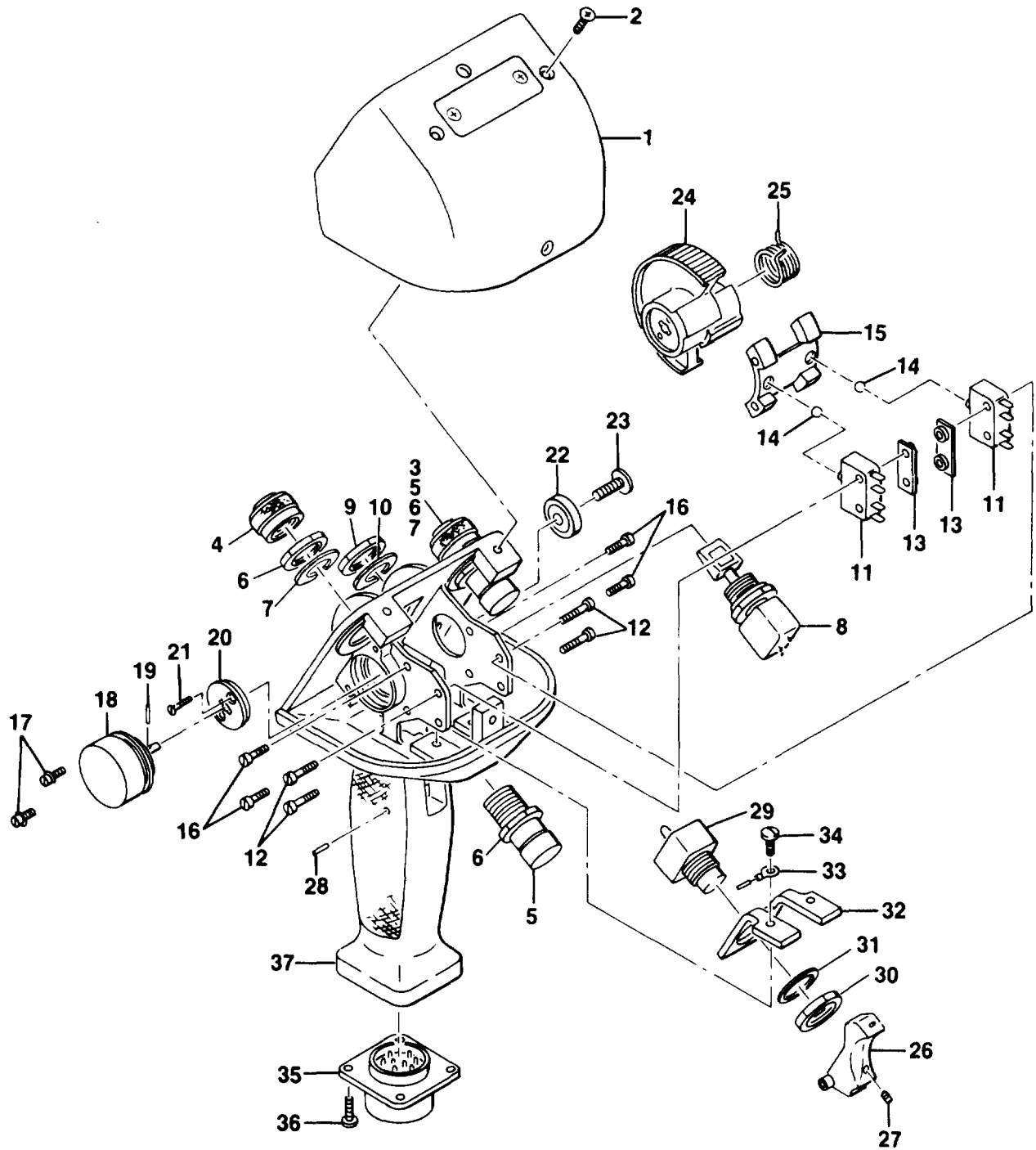
Shop Set, Intermediate Maintenance
NSN 4920-00-472-4183
Tool Kit, Electrical Repairer
NSN 5180-00-323-4915
Air Source, 35 psi
Multimeter

Reference

Avionic Cleaning and Corrosion Prevention/Control
TM 55-1500-343-23

GO TO NEXT PAGE

3-13. CONTROL PENDANT ASSY - REPAIR (cont)



GO TO NEXT PAGE

3-13. CONTROL PENDANT ASSY - REPAIR (cont)

3-13**1. Disassembly.**

- a. Remove cover (1) by removing screws (2).
- b. Unscrew indicator lamps (3, 4) from light bodies (5). Remove light bodies by removing attaching nuts (6) and washers (7). Disconnect and tag electrical wiring.
- c. Remove boom position switch (8) by removing attaching nut (9) and washer (10). Disconnect and tag electrical wiring.
- d. Remove switches (11) by removing screws (12). Remove plates (13) and balls (14).
- e. Remove retainer (15) by removing screws (16).
- f. Turn screws (17) for removal of potentiometer (18). Twist potentiometer (18) until pin (19) aligns with slot in bearing (20). Disconnect and tag electrical wiring. Remove potentiometer.
- g. Remove bearings (20, 22) by removing screws (21, 23).
- h. Remove thumbwheel (24) and spring (25).
- i. Remove sealant from hole of setscrew (27). Remove trigger (26) by removing setscrew (27) and pin (28).
- j. Remove intercom switch (29) by removing attaching nut (30) and washer (31). Disconnect and tag electrical wiring.
- k. Remove bracket (32) and terminal lug (33) by removing screws (34).
- l. Remove connector (35) from grip (37) by removing screws (36).

2. Cleaning.**WARNING**

Use solvent in a well-ventilated area. Avoid prolonged breathing of fumes. Keep away from open flame. Solvent is flammable.

WARNING

Use approved personal protective equipment (goggles/face shield) when using compressed air. Air pressure is restricted to a maximum of 35 psi. Do not direct airstream towards self or other personnel.

GO TO NEXT PAGE

CAUTION

Do not immerse electrical components in cleaning solvent. Wipe clean with a cloth dampened in soap and water solution.

CAUTION

If parts are not to be inspected immediately after cleaning, dip them in preserving oil to prevent rust spots.

- a. Clean electrical connector contact pins with procedures outlined in TM 55-1500-343-23.
- b. Clean electrical component by wiping clean with cloth moistened with trichloroethylene. Wipe with a clean, dry cloth and allow to air dry.
- c. Immerse all non-electrical components, except bearings in solvent and rinse thoroughly. Dry with compressed air.

3. Inspection.

- a. Inspect control pendant for nicks, cracks, dent or gouges (refer to Task 2-11). Inspect for corrosion.
- b. Inspect switch for smooth operation.
- c. Inspect electrical connector for broken or missing pins. Check for crossed, stripped or damaged threads.
- d. Inspect electrical components for evidence of shorting or overheating. Check electrical wiring for frayed or broken insulation.
- e. Inspect identification plate for legibility and security of attachment.

4. **Repair.** Repair of parts is limited to the removal of minor nicks, burrs, scratches or other surface damage using aluminum oxide cloth or fine abrasive. Clean parts thoroughly after repair. If damage is extensive, or if minor repair will affect serviceability, replace the part.

GO TO NEXT PAGE

**THIS PAGE
INTENTIONALLY
LEFT BLANK**

GO TO NEXT PAGE

5. Reassembly.

- a. Install connector (35) onto grip (37) and secure using nuts (36).
- b. Install bracket (32) and terminal lug (33) and secure using screws (34).
- c. Connect electrical wiring to intercom switch, Install intercom switch (29) onto bracket (32) and secure using attaching nut (30) and washer (31).
- d. Install trigger (26) and secure using pin (28) and setscrew (27). Fill setscrew hole with adhesive.
- e. Install thumbwheel (24) and spring (25).
- f. Coat threads of screws (21, 23) with adhesive. Install bearings (20, 22) using screws (21, 23).
- g. Connect electrical wiring and insert pin (19) into potentiometer (18). Install potentiometer by aligning pin with slot in bearing (20) Push in and turn. Coat threads of screws (17) with adhesive and install.
- h. Coat threads of screws (16) with adhesive. Install retainer (15) using screws (16) and safety wire using lockwire.
- i. Coat threads of screws (12) with adhesive. Install plates (13), switches (11) and balls (14) and secure using screws (12). Safety wire screws using lockwire.
- j. Connect electrical wiring to boom position switch (8). Install switch and secure using attaching nut (9) and washer (10).

NOTE

Ensure caution (amber) and overtemp (red) lights are installed in correct light bodies on pendant assembly.

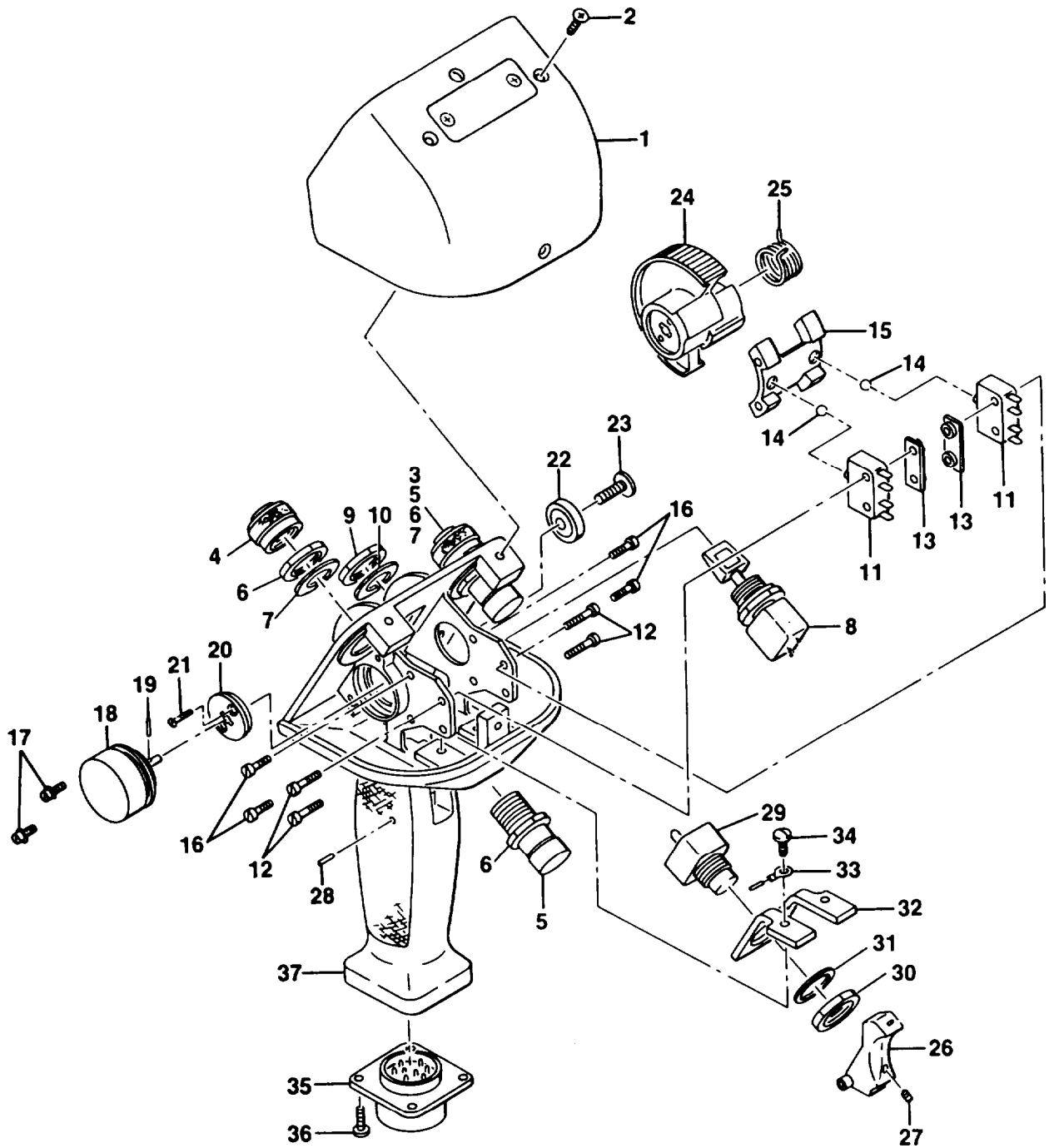
- k. Connect electrical wiring to indicator light bodies (5). Install light bodies and secure using attaching nuts (6) and washers (7). Install lights (3, 4).
- l. Install cover (1) and secure using screws (2). Seal cover with adhesive.

FOLLOW-ON MAINTENANCE:

Install control pendant
(Task 2-16)
conduct performance check
(Task 3-7)

GO TO NEXT PAGE

3-13. CONTROL PENDANT ASSY - REPAIR (cont)



END OF TASK

3-14. BOOMHEAD ASSEMBLY - ADJUST

3-14

This task covers: Adjustment

INITIAL SETUP**Personnel Required:**

67N, UH1 Helicopter Repairer
67T, UH60 Helicopter Repairer
91W, Medevac Medics

Equipment Condition:

Hoist installed in assembly stand

Parts/Materials:

None

Equipment Condition Para:

Task 2-5

Tools and Test Equipment:

None

References:

None

1. Adjust brake assembly in accordance with Task 3-18.
2. Adjust clutch assembly in accordance with Task 3-22.

FOLLOW-ON MAINTENANCE:

None

END OF TASK

3-15. BOOM HEAD ASSEMBLY - REPAIR

3-15**This task covers: Disassembly, Cleaning, Inspection, Repair and Reassembly****INITIAL SETUP****Personnel Required:**

67N, UH1 Helicopter Repairer (2)
 67T, UH60 Helicopter Repairer (2)
 91W, Medevac Medics

Equipment Condition:

Hoist installed in assembly stand
 Boom head assembly removed.

Parts/Materials:

Abrasive Cloth, Aluminum Oxide (Item 1, App. D)
 Adhesive RTV-732 (Item 2, App. D)
 Automatic Transmission Fluid (Item 3, App. D)
 Cleaning Solvent (Item 10, App. D)
 Electric Braid (Item 11, App. D)
 Heat Shrink Tubing (Item 26, App. D)
 Packing, MS28775-013
 Packing, MS28775-0156
 Packing, MS83461-/1-127
 Petrolatum (Item 19, App. D)
 Shims, 49001C6
 Pin Cotter, MS24665-359

Equipment Condition Para:

Task 3-5
 Task 2-20

Tools and Test Equipment:

Tool Kit, Aircraft Mechanics,
 NSN 5180-00-323-4692
 Shop Set, Intermediate Maintenance
 NSN 4920-00-472-4183
 Tool Kit, Electrical Repairer
 NSN 5180-00-323-4915
 Air Source, 35 psi
 Multimeter

References:

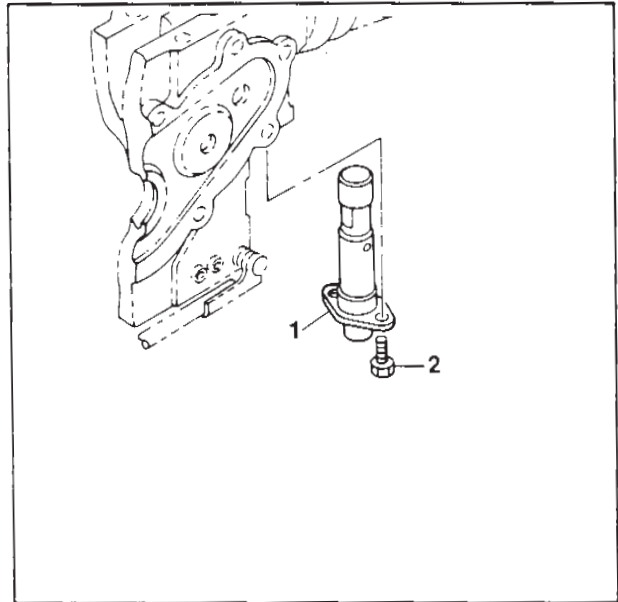
Avionic Cleaning and Corrosion Prevention/Control
 TM 1-1500-343-23
 Aircraft Electrical and Electronic Manual
 TM 55-1500-323-24
 Military Pyrotechnics
 TM 9-1370-203-20 & P
 TM 9-1370-203-34 & P

GO TO NEXT PAGE

1. Disassembly.**WARNING**

Rescue hoist cable cutter contains an explosive cartridge. Use extreme care when handling to prevent injury to personnel. Static producing clothing prohibited. When disconnecting electrical connector, install a piece of aluminum foil between cartridge pins and install shipment cap to prevent injury.

- a. Remove cable cutter (1) by removing bolts (2).

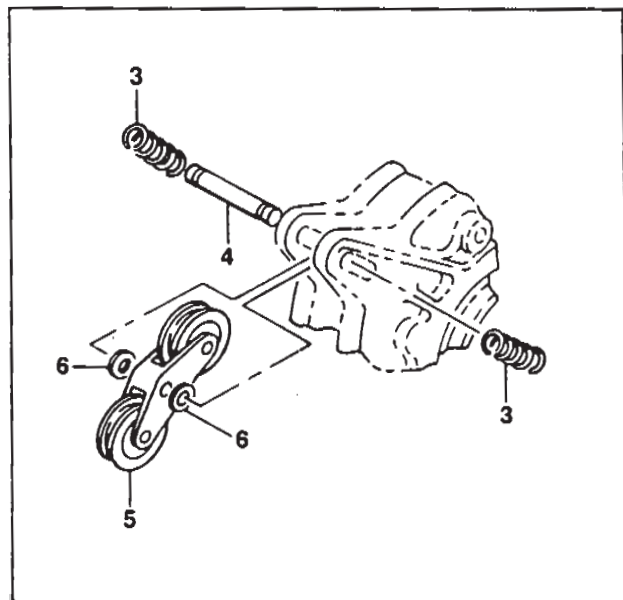
**WARNING**

Do not disassemble cable cutter. Do not remove cap. Handle with care and dispose of in accordance with munitions policies.

NOTE

The cartridge has a combined "shelf life" and installed life of not more than six years from date of manufacture. The maximum installed life is three years. Cartridge replacement is mandatory when the maximum combined shelf and installed life has expired.

- b. Remove extension springs (3) from pressure roller shaft (4).
- c. Remove roller shaft (4), pressure roller assembly (5) and washers (6).

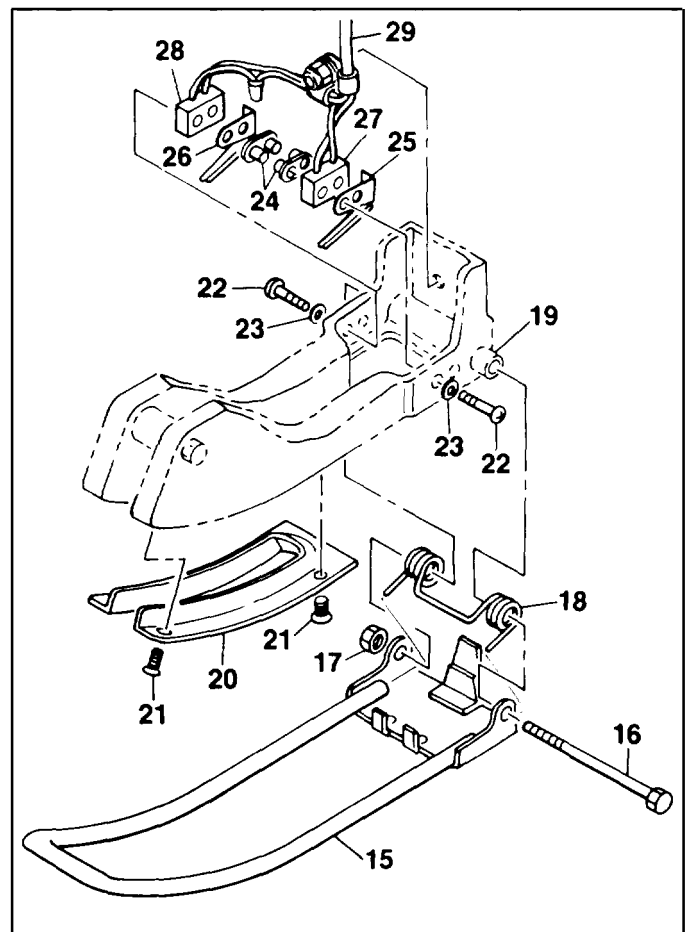
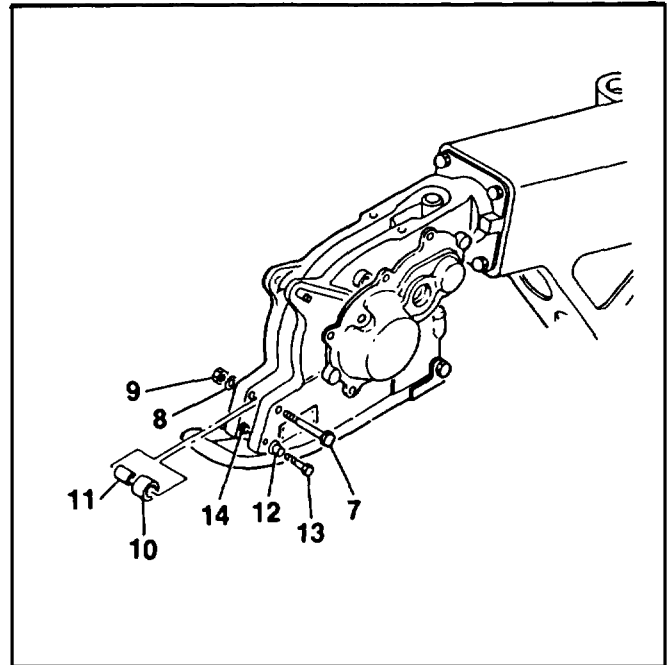


GO TO NEXT PAGE

3-15. BOOM HEAD ASSEMBLY - REPAIR (cont)

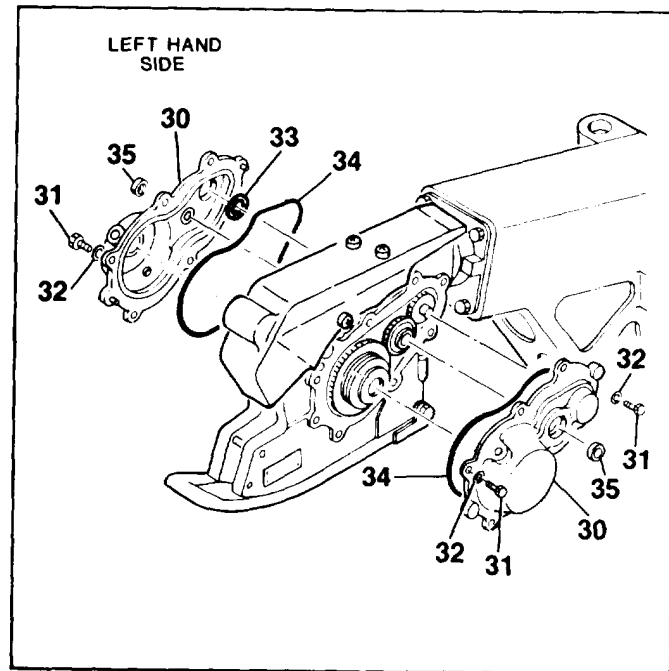
3-15

- d. Remove bolt (7), washer (8) and nut (9).
Remove spacer (10) and guide (11).
- e. Remove actuator stop (12) by removing screw (13) and nut (14).
- f. Remove actuator assembly (15) by removing bolt (16) and nut (17). Remove spring (18) from boom head boss (19).
- g. Remove cable guide (20) by removing screws (21).
- h. Remove screws (22), washers (23) and nutplates (24).
- i. Carefully remove actuator leaves (25, 26) from microswitch assemblies (27, 28) on wiring harness (29).



GO TO NEXT PAGE

- j. Remove left hand side cover assembly (30) by removing bolts (31) and washers (32). Remove shim (33) from bearing bore of cover (30).
- k. Remove nut (67) and washer (68) from spur gear shaft (70). Remove right hand side cover assembly (30) by removing bolts (31) and washers (32).
- l. Remove and discard packings (34) from covers (30).
- m. Remove sight plugs (35), as required, using a small drive pin,
- n. Remove gear assembly (36), thrust washer (37) and pin (38) from main housing assembly (39).
- o. Remove thrust washer (40) from sheave shaft (41). Rotate clutch assembly (42) and remove. Remove thrust washer (43). Remove and retain shim (44) if installed.
- p. Remove thrust washer (45) from sheave shaft (41). Rotate brake assembly (46) and remove. Remove thrust washer (47).
- q. Remove worm gear (48) and thrust washer (49) from main housing (39). Remove pin (50) if damaged.
- r. Remove retainer assembly (51) by removing screws (52). Remove and discard packing (53).



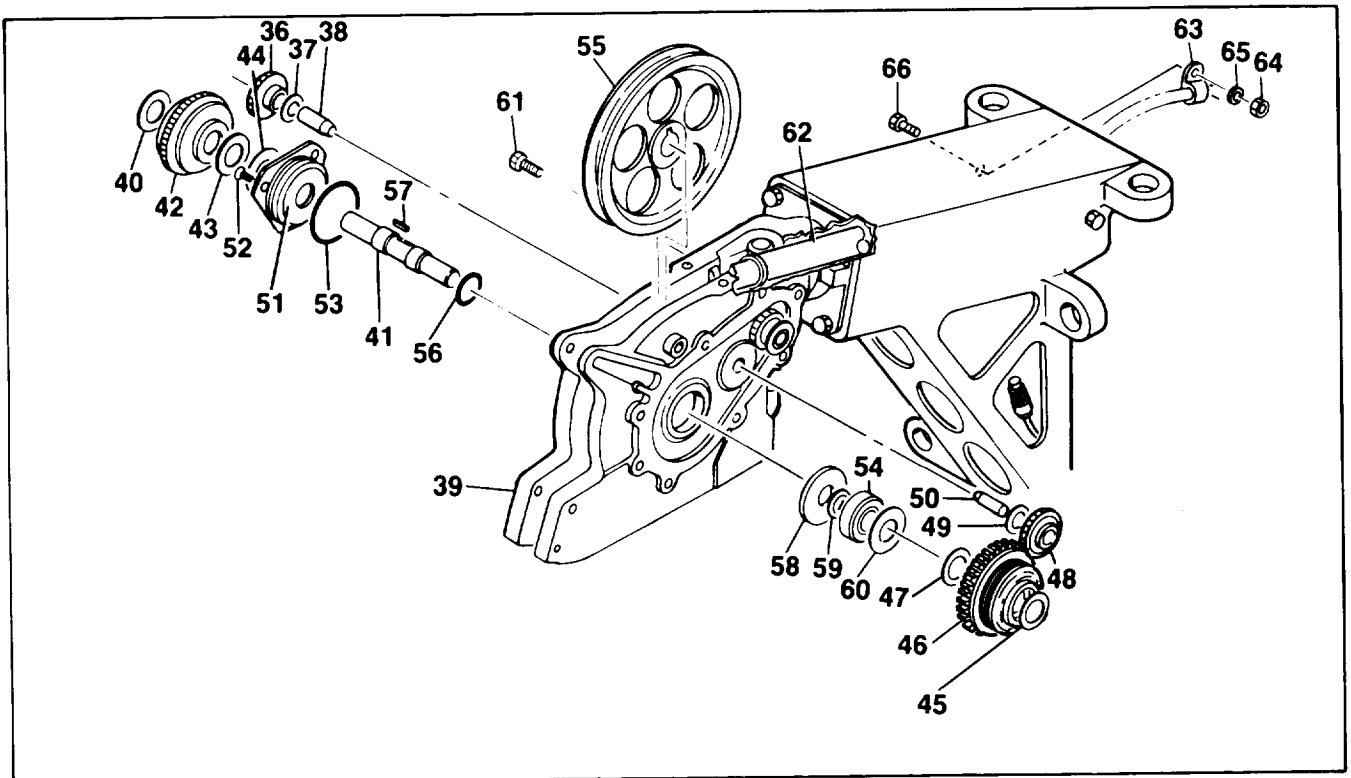
NOTE

Sheave shaft (41) is difficult to remove. Apply adequate force to abaft end using a rawhide mandrel or suitable tool.

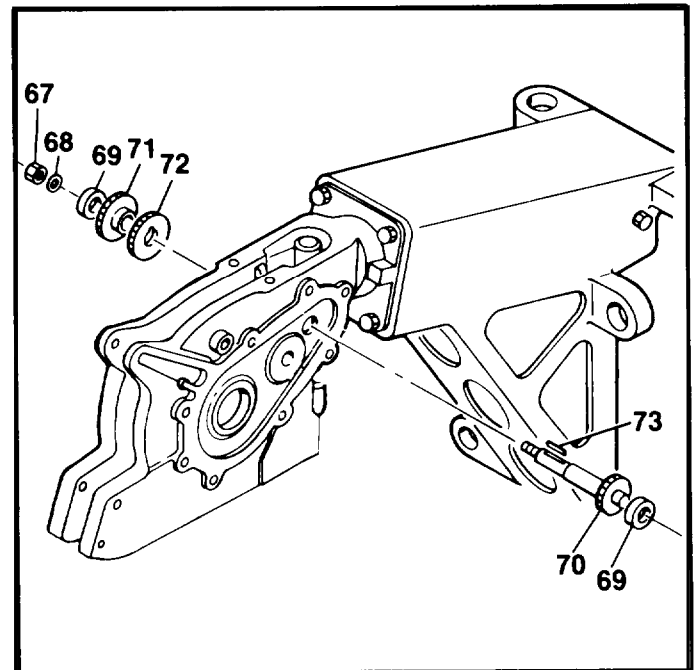
- s. Drive sheave shaft (41) from bearing (54) in main housing assembly (39). Slide sheave assembly (55) out through top of main housing assembly.
- t. Remove packing (56) and machine key (57) from sheave shaft (41). Discard packing.
- u. Using suitable tool, press seal assembly (58), sheave spacer (59), bearing (54) and shims (60) from main housing assembly (39).
- v. Remove lockwire from retaining screw (61) and discard. Remove screw, releasing flexible drive shaft (62).

GO TO NEXT PAGE

3-15. BOOM HEAD ASSEMBLY - REPAIR (cont)

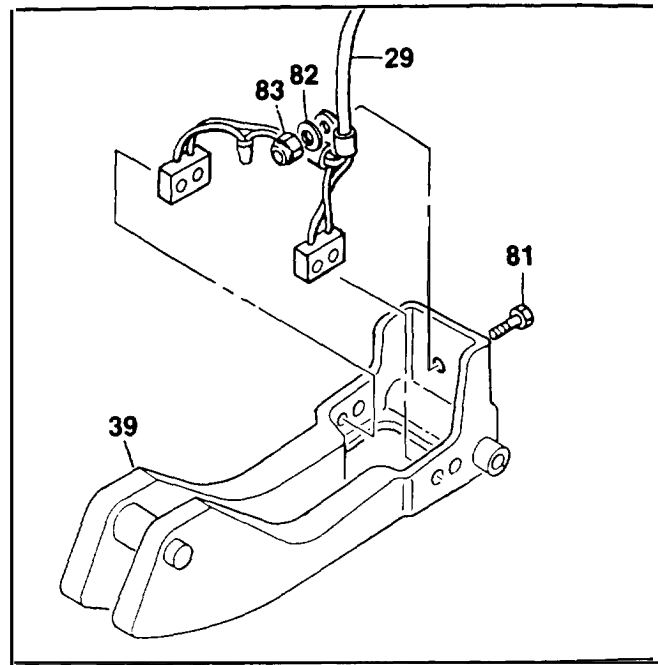
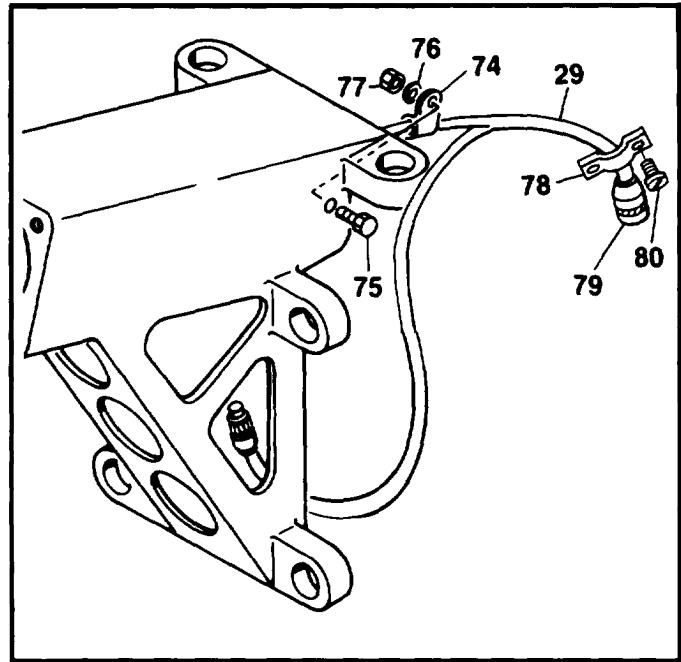


- w. Remove clamp (63) by removing nut (64), washer (65) and bolt (66). Pull flexible drive shaft (62) from boom head.
- x. Remove bearings (69) from spur gear shaft (70).
- y. Remove spur gear (71) and worm gear (72) from spur gear shaft (70).
- z. Remove spur gear shaft (70) from main housing assembly. Remove machine key (73) from shaft.



GO TO NEXT PAGE

- aa. Release wiring harness (29) from main housing assembly (39) by removing bolt (81), washer (82) and nut (83).
- ab. Remove clamp (74) by removing bolt (75), washer (76) and nut (77).
- ac. Remove clamp (78) from connector (79) by removing screws (80).
- ad. Remove heat shrink tubing and electrical braid from wiring harness (29).
- ae. Unscrew connector shell from connector (79). Slide shell and insulator away from connector. Remove pins from connector using a suitable pin removal tool.
- af. Carefully pull wiring harness (29) through boom head assembly from actuator end of housing.



GO TO NEXT PAGE

2. Cleaning.**WARNING**

Use solvent in a well ventilated area. Avoid prolonged breathing of fumes. Keep away from open flame. Use approved safety equipment.

WARNING

Use approved personal protective equipment (goggles/face shield) when using compressed air. Air pressure is restricted to a maximum of 35 psi. Do not direct airstream towards self or other personnel.

CAUTION

Do not immerse electrical components in cleaning solvent. Wipe clean with a cloth dampened in soap and water solution.

CAUTION

If parts are not to be inspected immediately after cleaning, dip them in preservation oil to prevent rust spots.

- a. Clean electrical connectors in accordance with the procedures outlined in TM 55-1500-343-23.
- b. Wash remaining components in solvent and rinse thoroughly. Dry with compressed air.

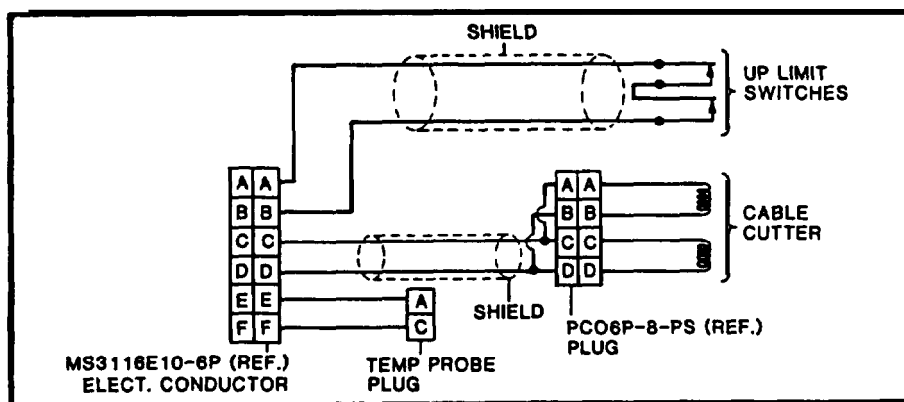
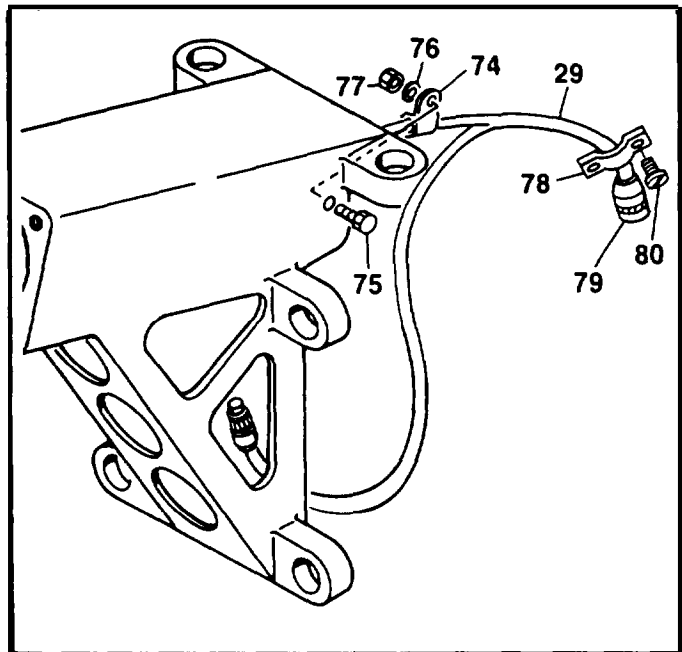
3. Inspection.

- a. Inspect all parts for nicks, cracks, scratches and dents (refer to Task 2-11).
 - b. Inspect for corrosion (refer to Task 2-11) and evidence of leakage.
 - c. Inspect all threaded parts for crossed, stripped and damaged threads.
 - d. Inspect electrical wiring for frayed and broken insulation. Check for cuts and tears.
 - e. Inspect electrical connectors for bent, broken or missing pins. Inspect for evidence of overheating or shorting.
 - f. Inspect identification and lubrication plates for legibility and security of attachment.
4. **Repair.** Repair of parts is limited to the removal of minor nicks, burrs, scratches or other surface damage using aluminum oxide cloth or fine abrasive. Clean parts thoroughly after repair. If damage is extensive, or if minor repair will affect serviceability, replace the part.

GO TO NEXT PAGE

5. Reassembly.

- a. Place electrical braid over both leads of actuator assembly, Route shielded leads through access hole in boom head housing.
- b. Slide approximately 10 inches (25.4 cm) of heat shrink tubing over cable cutter and actuator wires until it butts against housing, Shrink tubing in place.
- c. Slide connector shell, insulator, approximately 5 inches (12.7 cm) of heat shrink tubing, and 3 inches (7.62 cm) of electrical braid onto wire harness (29) and thermal switch connector wiring.
- d. Install pins into connector (79) in accordance with wiring diagram.
- e. Assemble connector (79). Slide electrical braid flush with connector and twist braid until secured. Slide heat shrink tubing over braid and shrink tubing in place.
- f. Install clamp (78) onto connector (79) and secure using screws (80).
- g. Secure wire harness (29) to boom head housing using clamp (74), bolt (75), washer (76) and nut (77).



GO TO NEXT PAGE

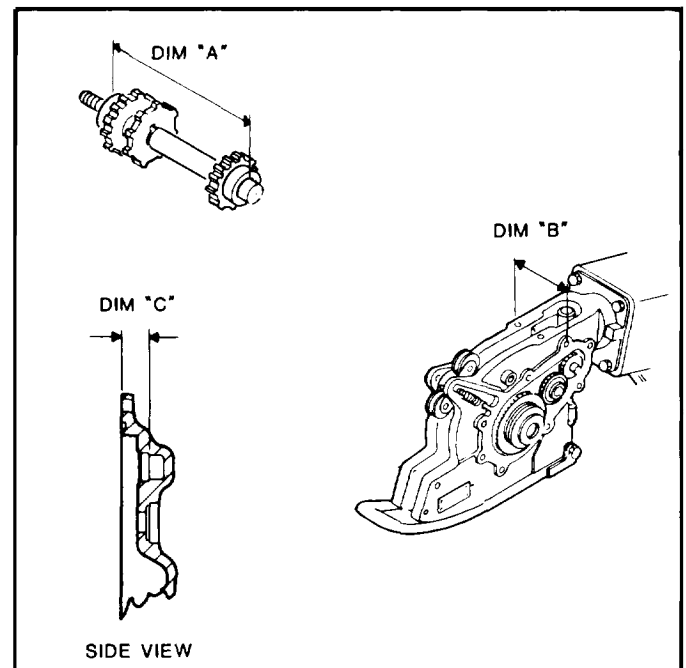
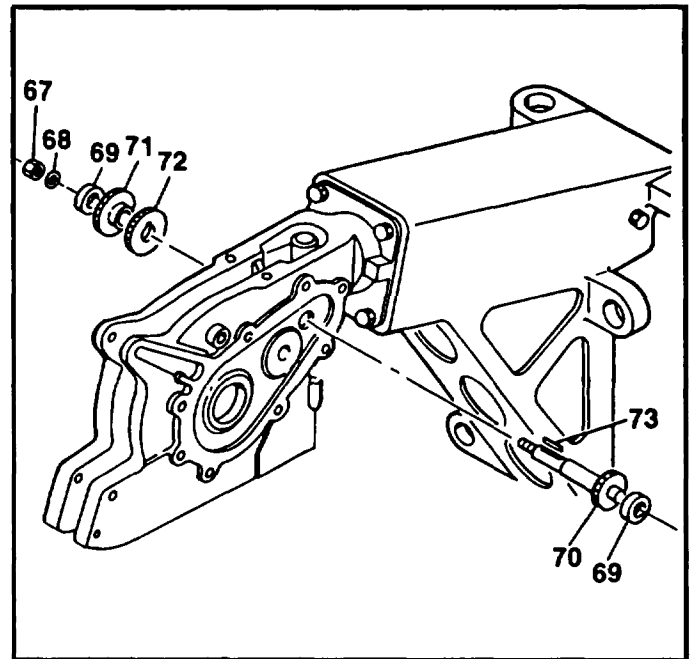
3-15. BOOM HEAD ASSEMBLY - REPAIR (cont)

3-15

h. Measure and adjust end play of spur gear shaft (70) as follows;

- (1) Install machine key (73), spur gear (72) and worm gear (71) on spur gear shaft (70). Press fit bearings (69) onto spur gear shaft. Measure distance between outer faces of bearings (dimension A).
- (2) Measure thickness of main housing assembly between flanges where side cover assemblies make contact (dimension B).
- (3) Measure depth of side cover assemblies from face to bottom of bearing bores (dimension C).
- (4) Add dimensions B and C. From this value, subtract dimension A. The difference is the end play between side cover assemblies and bearings on the spur gear shaft.
- (5) Install shims (33) in bearing bores of both side cover assemblies so that **total end play is 0.002-0.005 in. (0.005-0.013 cm)**.
- (6) After completion of end play adjustment, remove one bearing (69), worm gear (71) and spur gear (72) from spur gear shaft (70).

- i. Install spur gear shaft (70) into main housing assembly (39).
- j. Install worm gear (72) with hub facing out onto exposed end of spur gear shaft (70).
- k. Install spur gear (71) with hub facing in onto exposed end of spur gear shaft (70).
- l. Install remaining bearing (69) onto spur gear shaft (70).



GO TO NEXT PAGE

3-15. BOOM HEAD ASSEMBLY - REPAIR (cont)**3-15**

- m. Install flexible drive shaft (62) so that shaft bottoms out in boom head assembly. Worm of shaft must be visible in boom head housing (39).
- n. Secure flexible drive shaft (62) using retaining screw (61). Safety wire screw to side housing when installed using lockwire.
- o. Install clamp (63) using nut (64), washer (65) and bolt (66).

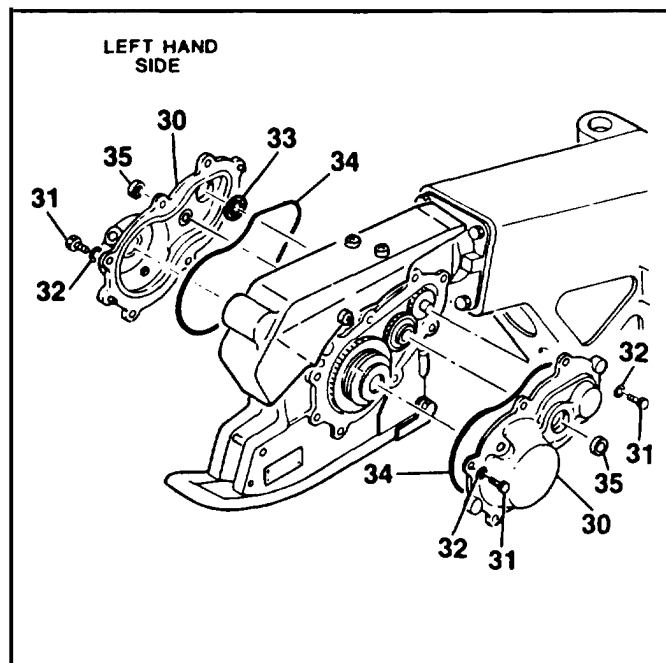
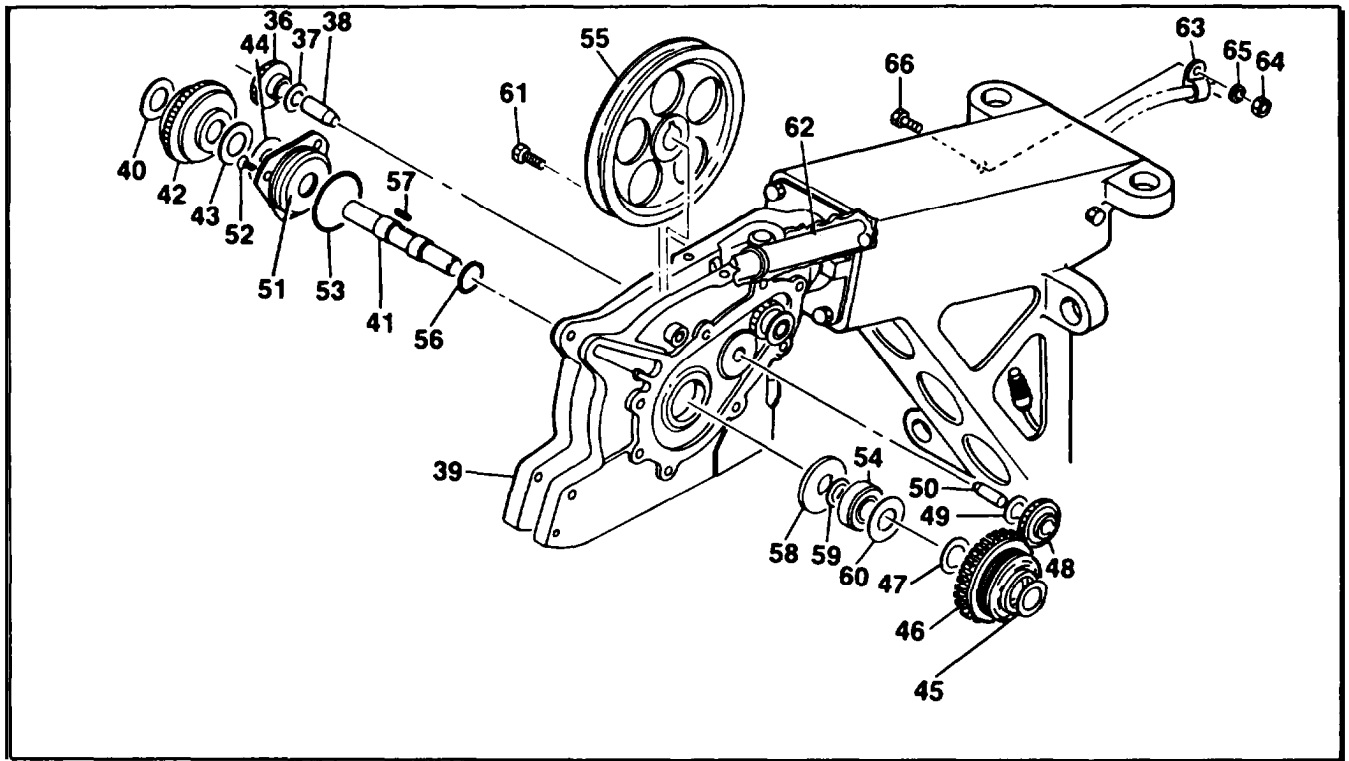
NOTE

Rotate flexible drive shaft (62) to ensure smooth operation, free of binding.

- p. Lubricate packing (56). Install machine key (57) and packing on sheave shaft (41).
- q. Install shim (58) into main housing (39). Using a suitable tool, press bearing (54) and seal (59) into housing. Install spacer (60).
- r. Slide sheave assembly (55) through top of main housing assembly (39) and install sheave shaft (41) in main housing assembly so that machine key (57) aligns with corresponding hole in sheave assembly and sheave shaft locks in place. Remove or install shims (60) to achieve **0.003-0.010 in. (0.008-0.025 cm) end play** of sheave. Ensure sheave is centered within 0.010 in. (0.025 cm) of main housing assembly centerline.
- s. Lubricate packing (53) and install on retainer assembly (51).
- t. Install retainer assembly (51) on main housing assembly (39) and secure using screws (52).
- u. Install pin (50), thrust washer (49) and worm gear (48).
- v. Install thrust washer (47) on sheave shaft (41). Install brake assembly (46) with spring end out on sheave shaft and rotate brake assembly to lock in place. Install thrust washer (45) on sheave shaft.
- w. Install thrust washer (43) on sheave shaft (41). Install clutch assembly (42) with spring end out on sheave shaft and rotate clutch to lock in place. Install thrust washer (40) on sheave shaft.
- x. Install pin (38), thrust washer (37) and gear assembly (36) with hub side in on main housing assembly (39).
- y. Lubricate side cover packings (34) and install on side cover assemblies (30). Install sight plugs (35) on side cover assemblies using adhesive.
- z. Install side cover assembly (30) and secure using bolts (31) and washers (32). **Torque bolts to 20-25 in-lbs.**
- aa. Install nut (67) and washer (68) onto spur gear shaft (70). **Torque nut to 20.25 in-lbs.**
- ab. Install left hand side cover assembly (30) and secure using bolts (31) and washers (32). **Torque bolts to 20-25 inch-lbs.**

GO TO NEXT PAGE

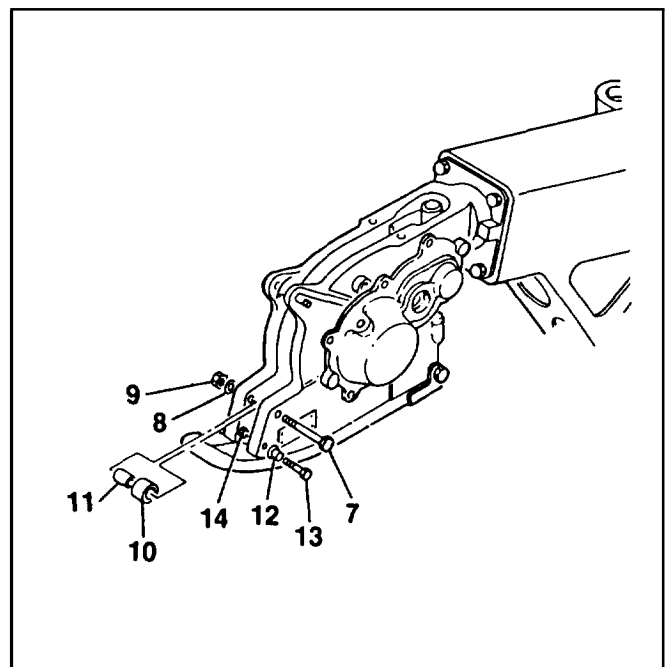
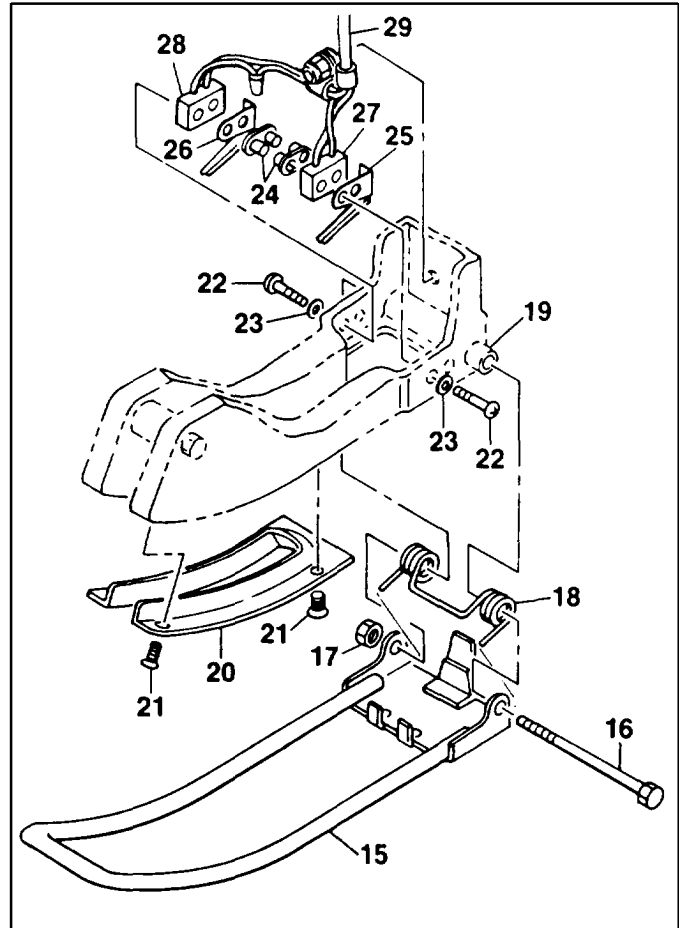
3-15. BOOM HEAD ASSEMBLY - REPAIR (cont)



GO TO NEXT PAGE

3-15. BOOM HEAD ASSEMBLY - REPAIR (cont)

- ac. Secure wiring harness (26) using bolt (27), washer (28) and nut (29).
- ad. Install actuator leaves (25) and position with microswitch assemblies into boom housing, Secure using screws (22), washers (23) and nutplates (24).
- ae. Install cable guide (20) using screws (21).
- af. Position spring (18) onto boom head boss, ensuring snug fit.
- ag. Position ends of spring (18) into hollow end of actuator (15) while positioning actuator to boom head housing. Fit bolt (16) through actuator assembly and spring. Secure using nut (17).
- ah. Adjust actuator assembly (Task 2-24).
- ai. Install actuator stop (12) using screw (13) and nut (14).
- aj. Position spacer (10) and guide (11). Install bolt (7), washer (8) and nut (9).



GO TO NEXT PAGE

3-15. BOOM HEAD ASSEMBLY - REPAIR (cont)

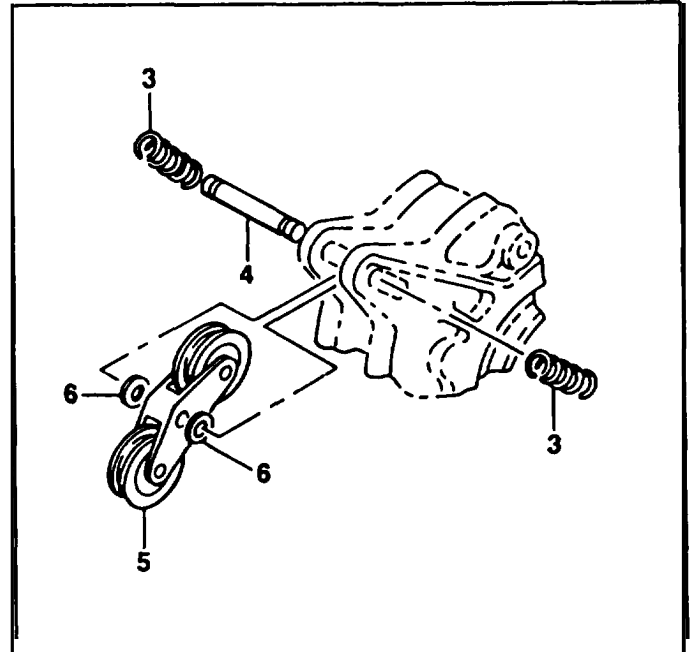
3-15

- ak. Install roller shaft (4), pressure roller assembly (5) and washers (6).
- al. Install extension springs (3) onto roller shaft (4).

WARNING

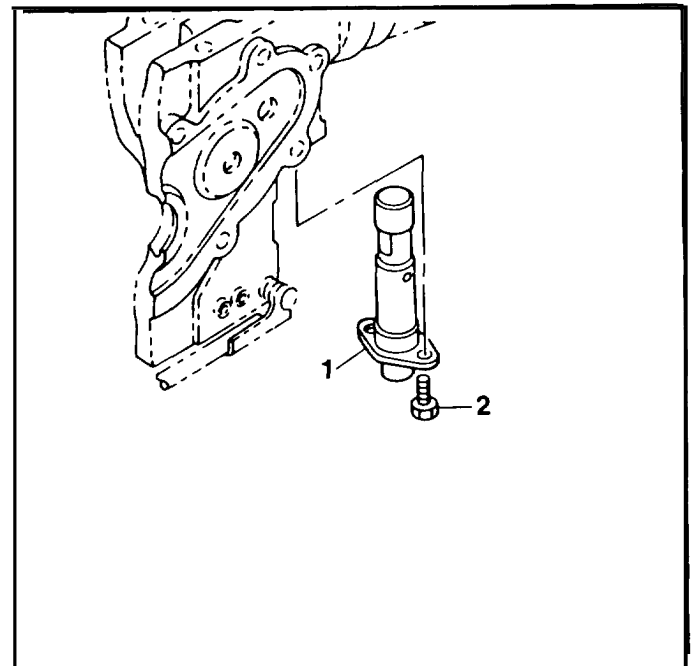
Rescue hoist cable cutter contains an explosive cartridge. Use extreme care when handling to prevent injury to personnel.

- am. Install cable cutter (1) using bolts (2).



FOLLOW-ON MAINTENANCE:

- Install boom head assembly (Task 2-20)
- Conduct performance check (Task 3-7)



END OF TASK

3-16. BRAKE ASSEMBLY - INSPECT

3-16

This task covers: Inspection

INITIAL SETUP

Personnel Required:

67N, UH1 Helicopter Repairer
 67T, UH60 Helicopter Repairer
 91W, Medevac Medics

Equipment Condition:

Hoist installed in assembly stand
 Brake assembly removed

Parts/Materials:

None

Equipment Condition Para:

Task 3-5
 Task 3-19

Tools and Test Equipment:

None

Reference

None

1. Inspect all parts for nicks, cracks, scratches and dents (refer to Task 2-11).
2. Inspect for corrosion (refer to Task 2-11).
3. Inspect clutch roller for smooth rotation.

FOLLOW-ON MAINTENANCE:

Repair brake assembly
 (Task 3-17)

END OF TASK

3-17. BRAKE ASSEMBLY - REPAIR**3-17**

This task covers: **Disassembly, Cleaning, Inspection, Repair and Reassembly**

INITIAL SETUP**Personnel Required:**

67N, UH1 Helicopter Repairer
 67T, UH60 Helicopter Repairer
 91W, Medevac Medics

Equipment Condition:

Hoist installed in assembly stand
 Brake assembly removed

Parts/Materials

Abrasive Cloth, Aluminum Oxide (Item 1,
 App. D)
 Automatic Transmission Fluid (Item 3,
 App. D)
 Cleaning Solvent (Item 10, App. D)

Equipment Condition Para:

Task 3-5
 Task 3-19

Tools and Test Equipment:

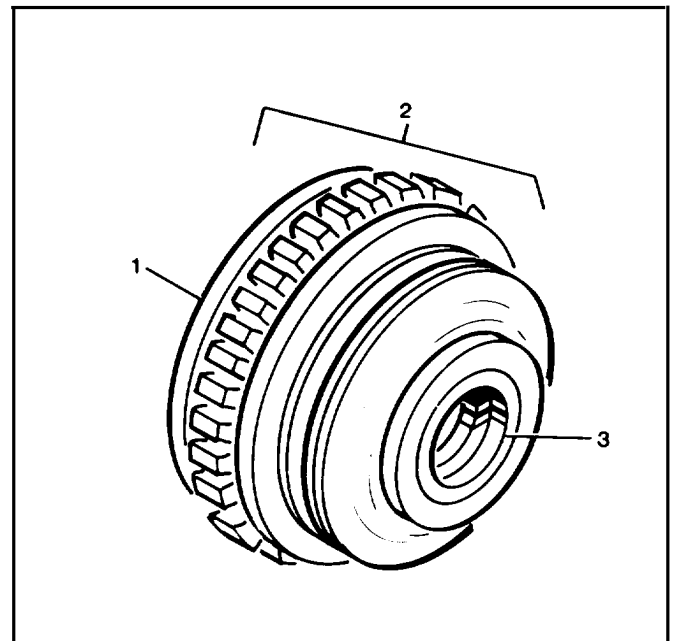
Tool Kit, Aircraft Mechanics,
 NSN 5180-00-323-4692
 Shop Set, Intermediate Maintenance
 NSN 4920-00-472-4183
 Air Source, 35 psi

References:

None

1. Disassembly.

- a. Release spring tension on brake assembly (1) by pressing down on plate (2). Hold while removing ring (3).
- b. Remove retaining ring (3).



GO TO NEXT PAGE

3-17. BRAKE ASSEMBLY - REPAIR (cont)

- c. Remove backing plate (2), disc assembly (4) and pressure plate (5).
- d. Remove key (6), springs (7) and shim (8).
- e. Press clutch roller (9) out of hub (10).

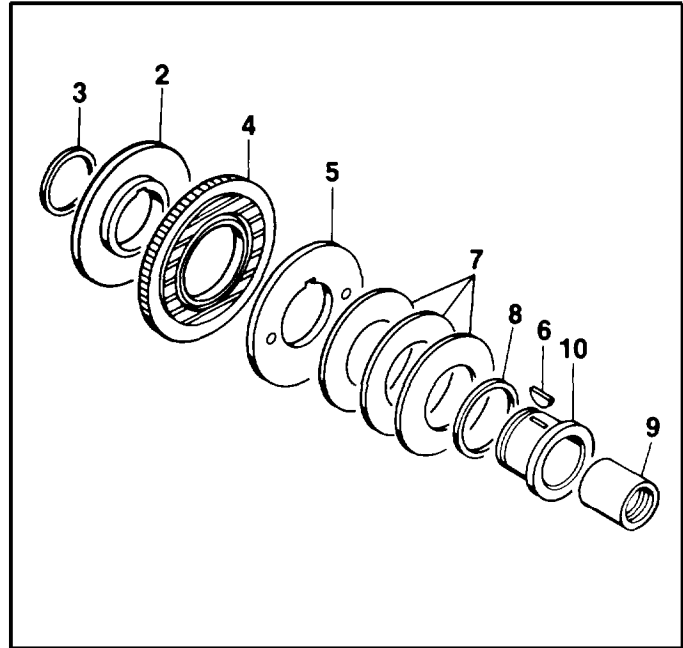
2. Cleaning.

WARNING

Use solvent in a well ventilated area. Avoid prolonged breathing of fumes. Keep away from open flame, Use approved safety equipment.

WARNING

Use approved personal protective equipment (goggles/face shield) when using compressed air. Air pressure is restricted to a maximum of 35 psi. Do not direct airstream towards self or other personnel.



CAUTION

If parts are not to be inspected immediately after cleaning, dip them in preservative oil to prevent rust spots.

- a. Clean disc assembly with cloth soaked in solvent.
- b. Wash remaining components in solvent and rinse thoroughly. Dry with compressed air.

3. Inspection. Inspect compormts in accordance with Task 3-16.

4. Repair. Repair of parts is limited to the removal of minor nicks, burns, scratches or other surface damage using aluminum oxide cloth or fine abrasive. Clean parts thoroughly alter repair. If damage is extensive, or if minor repair will affect serviceability, replace the part.

GO TO NEXT PAGE

3-17. BRAKE ASSEMBLY - REPAIR (cont)

3-17

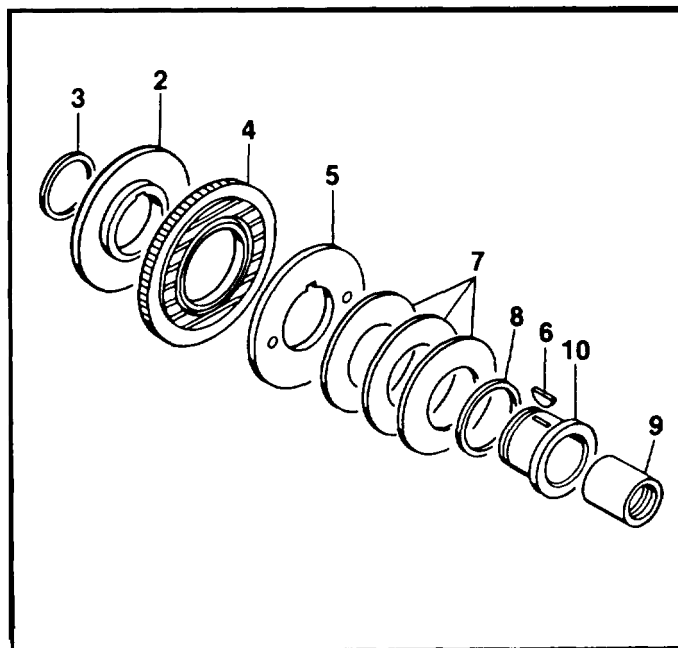
5. Reassembly.

- a. Soak hub (10), backing plate (2), disc assembly (4) and pressure plate (5) in transmission fluid for 5 minutes.

NOTE

Lock arrow on clutch roller (9) should point counterclockwise when viewed from spring (7) end of hub (10).

- b. Press clutch roller (9) into hub (10).
- c. Install shim (8), springs (7), and key (6) on hub (2).
- d. Install pressure plate (5), disc assembly (4) and backing plate (2).
- e. Apply pressure to plate (2) to remove spring tension. Install retaining ring (3) on hub (10). Release plate (2).

**FOLLOW-ON MAINTENANCE:**

Install brake assembly
(Task 3-19)

END OF TASK

This task covers: Torque Check and Adjustment**INITIAL SETUP****Personnel Required:**

67N, UH1 Helicopter Repairer
 67T, UH60 Helicopter Repairer
 91W, Medevac Medics

Equipment Condition:

Hoist installed in assembly stand
 Brake assembly removed from hoist

Parts/Materials:

None

Equipment Condition Para:

Task 3-5
 Task 3-19

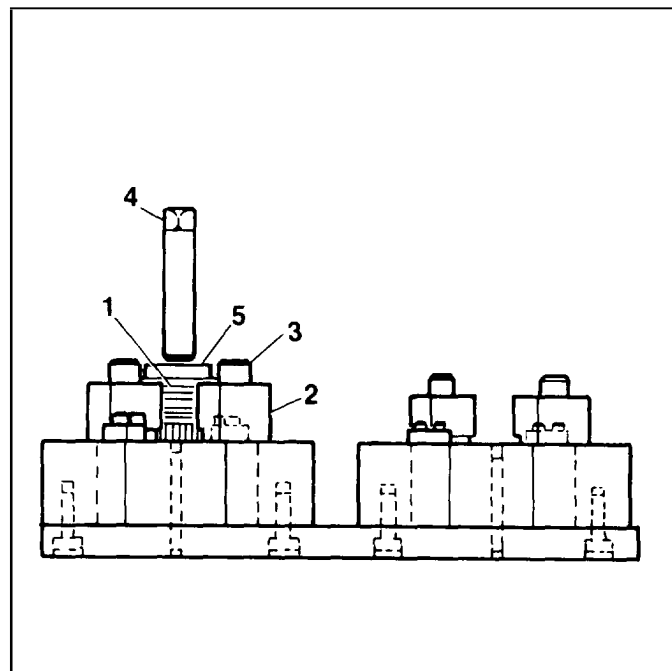
Tools and Test Equipment:

Tool Kit, Aircraft Mechanics,
 NSN 5180-00-323-4692
 Shop Set, Intermediate Maintenance
 NSN 4920-00-472-4183
 Clutch and Brake Holding Fixture,
 42277-716

References:

None

1. Install brake assembly (1) in Clutch and Brake Holding Fixture with spring end down. Engage gear discs on fixture with friction disc of brake. Install dowel pin (4) into center of clutch roller (5).
2. Position clamps (2) onto friction disc and tighten screws (3).
3. Using a torque wrench attached to the dowel pin (4), rotate clutch roller (5) in direction of arrow on clutch roller face. Clutch roller shall rotate freely.
4. Using a torque wrench rotate clutch roller (5) in opposite direction of arrow on clutch roller face. **Clutch roller shall slip at 21-25 in-lbs.**
5. Remove dowel pin (4) from clutch roller (5). Remove brake assembly from Clutch and Brake Holding Fixture, by loosening screws (3) and rotating clamps (2) free of friction disc.



GO TO NEXT PAGE

3-18. BRAKE ASSEMBLY - ADJUST (cont)

3-18

6. If torque required to slip clutch roller **exceeds 25 in-lbs.**, proceed as follows;
- a. Disassemble brake assembly in accordance with Task 3-17.

NOTE

Removal of brake assembly shims lowers torque required to cause clutch roller slippage.

- b. Remove brake assembly shim(s) as required to adjust clutch torque.
 - c. Reassemble brake assembly and repeat steps 1 through 4 to ensure proper brake and clutch operation.
7. If clutch roller slippage occurs at **less than 21 in-lbs.**, proceed as follows;
- a. Disassemble brake assembly in accordance with Task 3-17.

NOTE

Addition of brake assembly shims raises torque required to cause clutch roller slippage.

- b. Add brake assembly shim(s) as required to adjust clutch torque.
- c. Reassemble brake assembly and repeat steps 1 through 4 to ensure proper brake and clutch operation.

FOLLOW-ON MAINTENANCE:

Install brake assembly
(Task 3-19)

END OF TASK

3-19. BRAKE ASSEMBLY - REPLACE

This task covers: Removal and Installation

INITIAL SETUP

Personnel Required:

67N, UH1 Helicopter Repairer
 67T, UH60 Helicopter Repairer
 91W, Medevac Medics

Equipment Condition:

Hoist installed in assembly stand
 Boom head assembly drained

Parts/Materials:

Automatic Transmission Fluid
 (Item 3, App. D)

Equipment Condition Para:

Task 3-5
 Task 2-18

Tools and Test Equipment:

Tool Kit, Aircraft Mechanics
 NSN 5180-00-323-4692
 Shop Set, Intermediate Maintenance
 NSN 4920-00-472-4183

References:

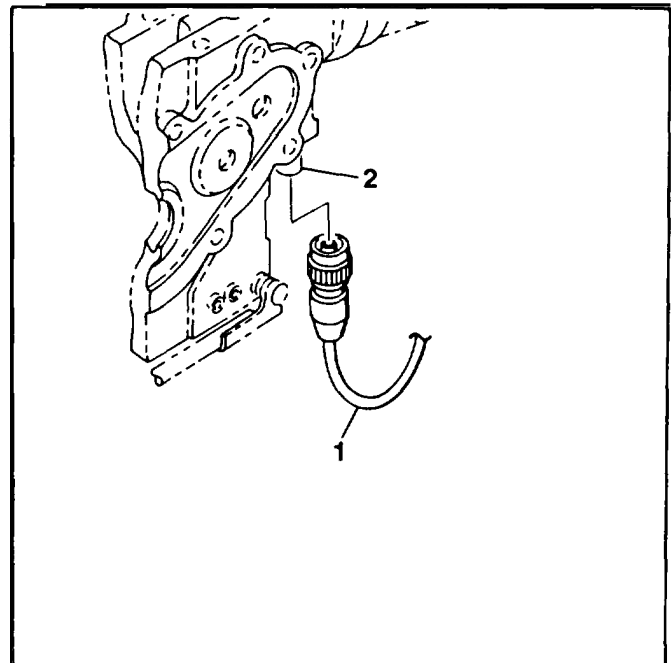
None

1. Removal

WARNING

Rescue hoist cable cutter contains an explosive cartridge. Use extreme care when handling to prevent injury to personnel. Static producing clothing prohibited. When disconnecting electrical connector, install a piece of aluminum foil between cartridge pins and install shipping cap to prevent injury

- a. Disconnect electrical connector (1) from cable cutter (2).



GO TO NEXT PAGE

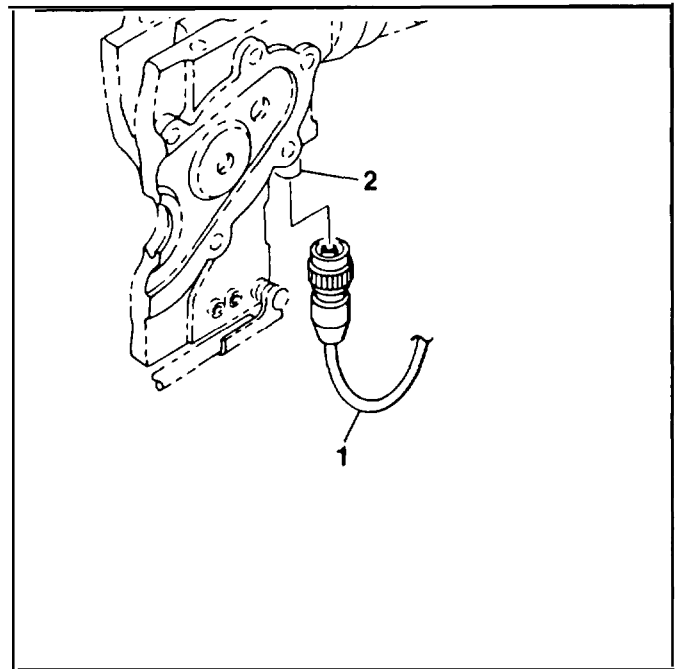
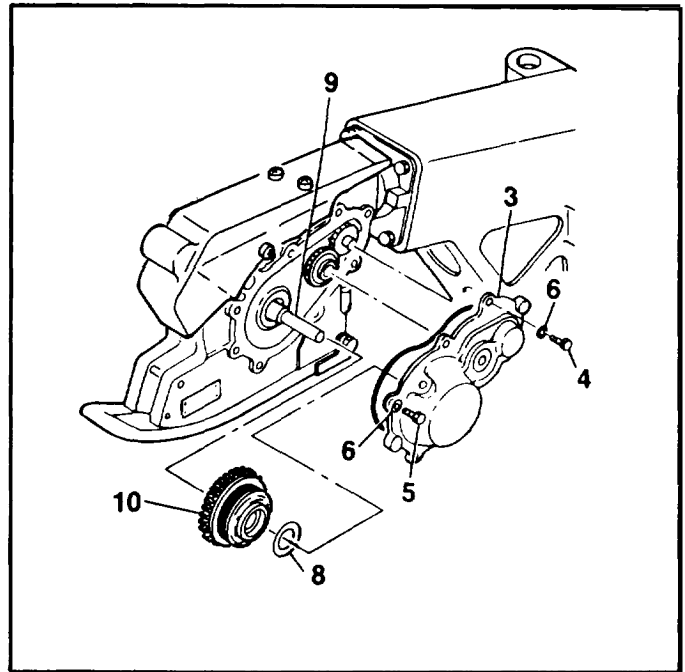
3-19. BRAKE ASSEMBLY - REPLACE (cont)

3-19

- b. Remove side cover assembly (3) by removing bolts (4, 5) and washers (6). Remove and discard packing (7).
- c. Remove thrust washer (8) from sheave shaft (9).
- d. Turn brake assembly (10) clockwise to unlock, and remove from sheave shaft (9).

2. Installation.

- a. Install brake assembly (10), with spring end out, on sheave shaft (9). Turn brake assembly counterclockwise to lock in place.
- b. Install thrust washer (8) on sheave shaft (9).
- c. Lubricate packing (7) and install onto side cover assembly (3). Install side cover assembly and secure using bolts (4, 5) and washers (6).
- d. Connect electrical connector (1) to cable cutter (2).

**FOLLOW-ON MAINTENANCE:**

Semite boom head assembly
(Task 2-18)
Conduct operational check
(Task 3-7)

END OF TASK

3-20. CLUTCH ASSEMBLY - INSPECTION

3-20

This task covers: Inspection

INITIAL SETUP

Personnel Required:

67N, UH1 Helicopter Repairer
67T, UH60 Helicopter Repairer
91W, Medevac Medics

Equipment Condition:

Hoist installed in assembly stand
Clutch assembly removed

Parts/Materials:

None

Equipment Condition Para:

Task 3-5
Task 3-19

Tools and Test Equipment:

None

References:

General Aircraft Maintenance Manual
TM 55-1500-204-25/1
Aircraft Weapons Systems Cleaning and Corrosion Control
TM 55-1500-344-23

-
1. Inspect all parts for nicks, cracks, scratches and dents (refer to Task 2-11).
 2. Inspect for corrosion (refer to Task 2-11).
 3. Inspect clutch roller for smooth rotation.

FOLLOW-ON MAINTENANCE:

Repair clutch assembly
(Task 3-21)

END OF TASK

3-21. CLUTCH ASSEMBLY - REPAIR

3-21

This task covers: Disassembly, Cleaning, Inspection, Repair and Reassembly

INITIAL SETUP**Personnel Required:**

67N, UH1 Helicopter Repairer
67T, UH60 Helicopter Repairer
91W, Medevac Medics

Equipment Condition:

Hoist installed in assembly stand
Clutch assembly removed

Parts/Materials:

Abrasive Cloth, Aluminum Oxide (Item 1,
App. D)
Automatic Transmission Fluid (Item 3,
App. D)
Cleaning Solvent (Item 10, App. D)

Equipment Condition Para:

Task 3-5
Task 3-23

Tools and Test Equipment:

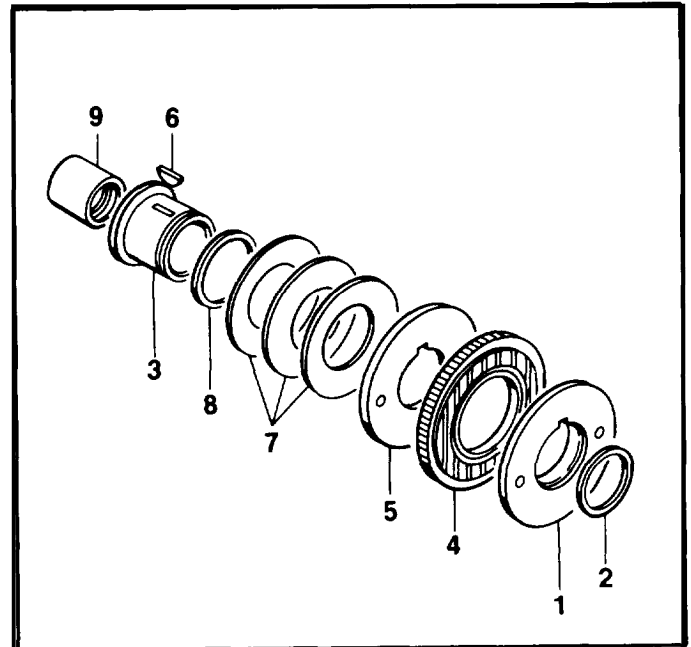
Tool Kit, Aircraft Mechanics,
NSN 5180-CW323-4692
Shop Set, Intermediate Maintenance
NSN 4920-00-472-4183
Air Source, 35 pai

Reference

None

1. Disassembly.

- a. Release spring tension on clutch assembly by applying pressure to plate (1) while removing retaining ring (2). Remove retaining ring from hub (3).
- b. Remove backing plate (1), disc assembly (4) and pressure plate (5).
- c. Remove key (6), springs (7) and shim (8).
- d. Press clutch roller (9) out of hub (3).



GO TO NEXT PAGE

2. Cleaning.**WARNING**

Use solvent in a well ventilated area. Avoid prolonged breathing of fumes. Keep away from open flame. Use approved safety equipment.

WARNING

Use approved personal protective equipment (goggles/face shield) when using compressed air. Air pressure is restricted to a maximum of 35 psi. Do not direct airstream towards self or other personnel.

CAUTION

If parts are not to be inspected immediately after cleaning, dip them in preservative oil to prevent rust spots.

- a. Clean disc assembly with cloth soaked in solvent.
 - b. Wash remaining components in solvent and rinse thoroughly. Dry with compressed air.
- 3. Inspection.** Inspect components in accordance with Task 3-20.
- 4. Repair.** Repair of parts is limited to the removal of minor nicks, burns, scratches or other surface damage using aluminum oxide cloth or fine abrasive. Clean parts thoroughly after repair. If damage is extensive, or if minor repair will affect serviceability, replace the part.

GO TO NEXT PAGE

3-21. CLUTCH ASSEMBLY - REPAIR (cont)

3-21

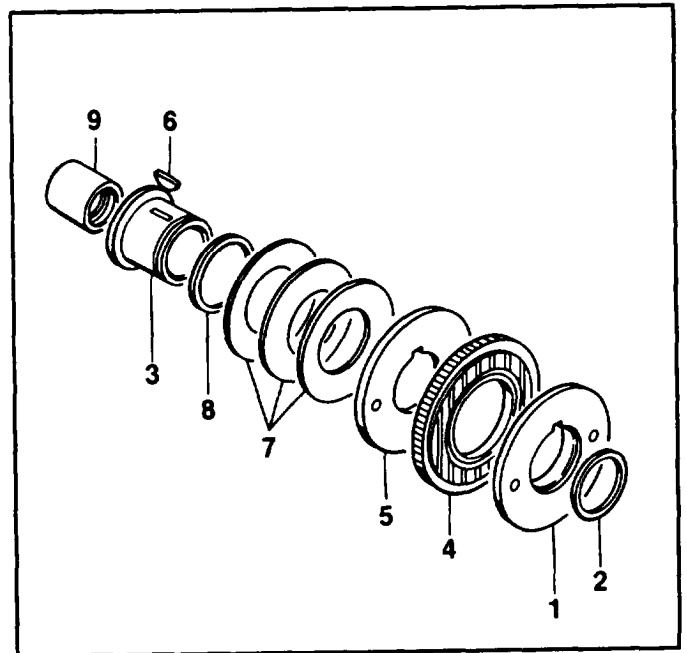
5. Reassembly.

- a. Soak hub(3), backing plate (1), disc assembly (4) and pressure plate (5) in transmission fluid for 5 minutes.

NOTE

Lock arrow on clutch roller (9) should point counterclockwise when viewed from retaining ring (2) end of hub (3).

- b. Press clutch roller (9) into hub (3).
- c. Install shim (8), springs (7), and key (6) on hub (3).
- d. Install pressure plate (5), disc assembly (4) and backing plate (1).
- e. Apply pressure to plate (1) to relieve spring tension. Install retaining ring (2) on hub (3). Release plate (1). Release plate (1).

**FOLLOW-ON MAINTENANCE:**

Install clutch assembly
(Task 3-23)

END OF TASK

3-22. CLUTCH ASSEMBLY - ADJUST**3-22****This task covers: Torque Check and Adjustment****INITIAL SETUP****Personnel Required:**

67N, UH1 Helicopter Repairer
 67T, UH60 Helicopter Repairer
 91W, Medevac Medics

Equipment Condition:

Hoist installed in assembly stand
 Clutch assembly removed

Parts/Materials:

None

Equipment Condition Para:

Task 3-5
 Task 3-23

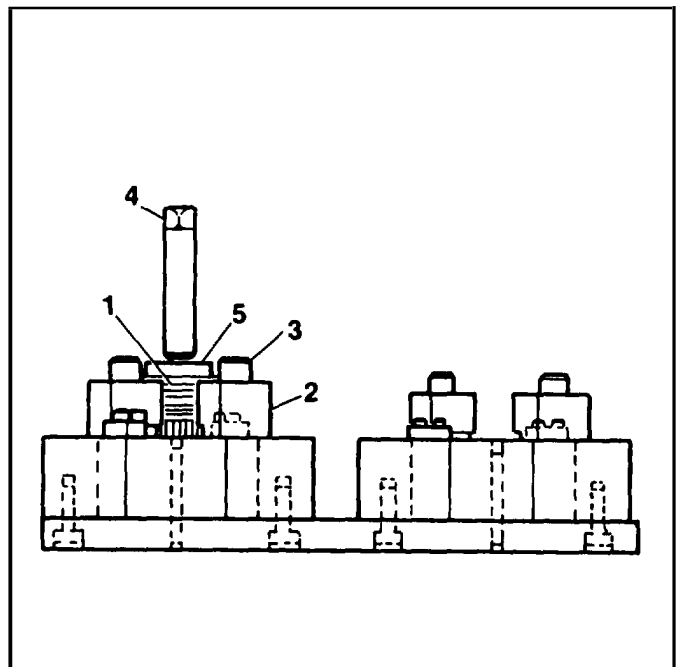
Tools and Test Equipment:

Tool Kit, Aircraft Mechanics
 NSN 5180-00-323-4692
 Shop Set, Intermediate Maintenance
 NSN 4920-00-472-4183
 Clutch and Brake Holding Fixture,
 42277-716

Reference

None

1. Install clutch assembly (1) in Clutch and Brake Holding Fixture with spring end down. Engage gear discs on fixture with friction disc of clutch.
2. Position clamps (2) onto friction disc and tighten screws (3). Install dowel pin (4) into center of clutch roller (5).
3. Using a torque wrench attached to the dowel pin, (4) rotate clutch roller (5) in direction of arrow on clutch roller face. Clutch roller shall rotate freely.
4. Using a torque wrench, rotate clutch roller (5) in opposite direction of arrow on clutch roller face. **Clutch roller shall slip at 21-25 in-lbs.**
5. Remove dowel pin (4) from clutch roller (5). Remove clutch assembly from Clutch and Brake Holding Fixture, by loosening screws(3) and rotating clamps (2) free of friction disc.

**GO TO NEXT PAGE**

3-22. CLUTCH ASSEMBLY - ADJUST (cont)

3-22

6. If torque required to slip clutch roller **exceeds 25 in-lbs.** proceed as follows:

- a. Disassemble clutch assembly in accordance with Task 3-21.

NOTE

Removal of clutch assembly shims lowers torque required to cause clutch roller slippage.

- b. Remove clutch assembly shim(s) as required to adjust clutch torque.
 - c. Reassemble clutch assembly and repeat steps 1 through 4 to ensure proper operation.
7. If clutch roller slippage occurs **at less than 21 in-lbs.** proceed as follows;

- a. Disassemble clutch assembly in accordance with Task 3-21.

NOTE

Addition of clutch assembly shims raises torque required to cause clutch roller slippage.

- b. Add clutch assembly shim(s) as required to adjust clutch torque.
- c. Reassemble clutch assembly and repeat steps 1 through 4 to ensure proper operation.

FOLLOW-ON MAINTENANCE:

Install clutch assembly
(Task 3-23)

END OF TASK

3-23. CLUTCH ASSEMBLY - REPLACE

This task covers: Removal and Installation

INITIAL SETUP

Personnel Required:

67N, UH1 Helicopter Repairer
 67T, UH60 Helicopter Repairer
 91W, Medevac Medics

Equipment Condition:

Hoist installed in assembly stand
 Boom head assembly drained

Parts/Materials:

Hydraulic Fluid (Item 13, App. D)

Equipment Condition Para:

Task 3-5
 Task 2-18

Tools and Test Equipment:

Tool Kit, Aircraft Mechanics
 NSN 5180-00-323-4692
 Shop Set, Intermediate Maintenance
 NSN 4920-W472-2183

References:

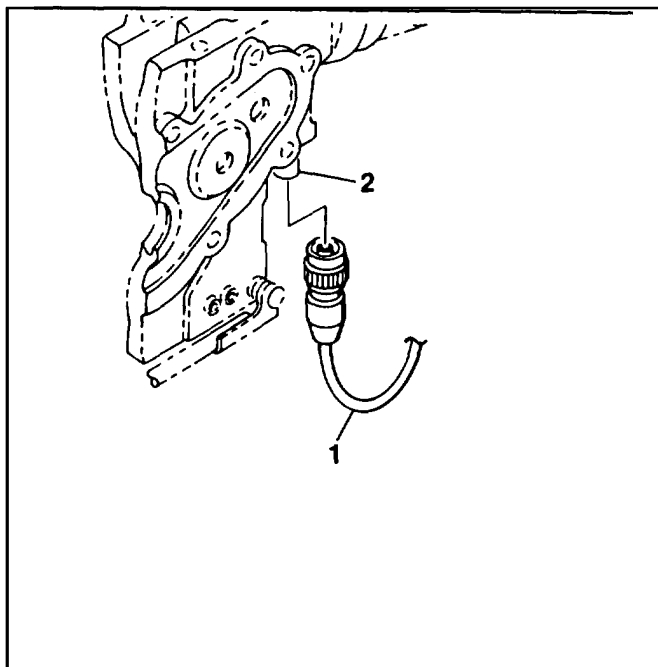
None

1. Removal.

WARNING

Rescue hoist cable cutter contains an explosive cartridge. Use extreme care when handling to prevent injury to personnel. Static producing clothing prohibited. When disconnecting electrical connector, install a piece of aluminum foil between cartridge pins and install shipping cap to prevent injury

- a. Disconnect electrical connector (1) from cable cutter (2).



GO TO NEXT PAGE

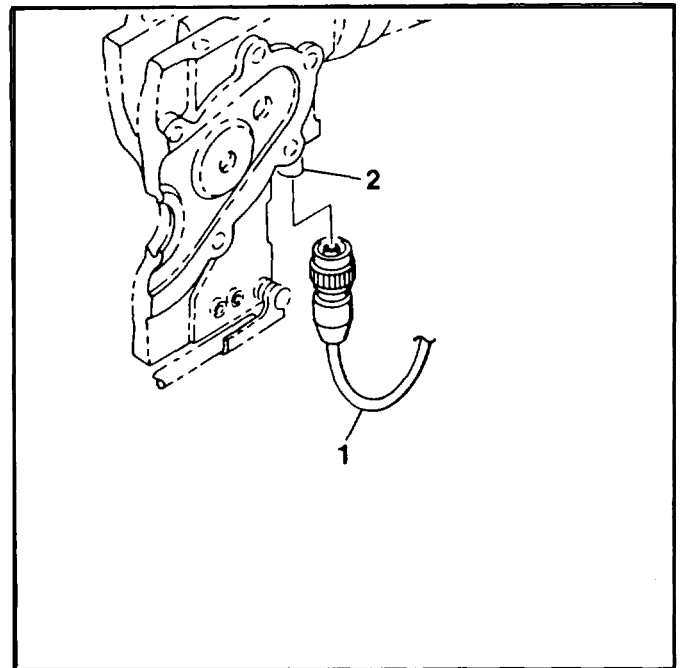
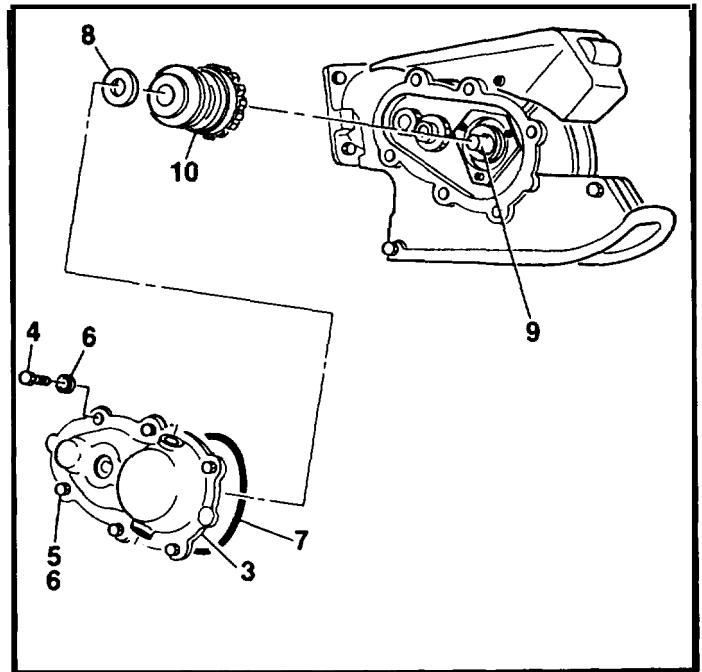
3-23. CLUTCH ASSEMBLY - REPLACE (cont)

3-23

- b. Remove side cover assembly (3) by removing bolts (4, 5) and washers (6). Remove and discard packing (7).
- c. Remove thrust washer (8) from sheave shaft (9).
- d. Turn clutch assembly (10) counterclockwise to unlock, and remove from sheave shaft (9).

2. Installation.

- a. Install clutch assembly (10), with spring end out, on sheave shaft (9). Turn clutch assembly clockwise to lock in place.
- b. Install thrust washer (8) on sheave shaft (9).
- c. Lubricate packing (7) and install onto side cover assembly (3). Install side cover assembly and secure using bolts (4, 5) and washers (6).
- d. Connect electrical connector (1) to cable cutter (2).

**FOLLOW-ON MAINTENANCE:**

Service boom head assembly
(Task 2-18)
Conduct operational check
(Task 3-7)

END OF TASK

**THIS PAGE
INTENTIONALLY
LEFT BLANK**

3-24. MICROSWITCH ASSEMBLY (FULL UP) - REPLACE**3-24****This task covers: Removal and Installation****INITIAL SETUP****Personnel Required:**

67N, UH1 Helicopter Repairer
 67T, UH60 Helicopter Repairer
 68F, Aircraft Electrical Repairer
 91W, Medevac Medics

Equipment Condition:

Hoist installed in assembly stand
 Boom head assembly removed
 Actuator assembly removed

Parts/Materials

Electric Braid (Item 11, App. D)
 Heat Shrink Tubing (Item 26, App. D)
 Packing, M83461/1-127
 Packing, MS28775-156
 Packing, MS28775-013

Equipment Condition Para:

Task 3-5
 Task 2-20
 Task 2-25

Tools and Test Equipment:

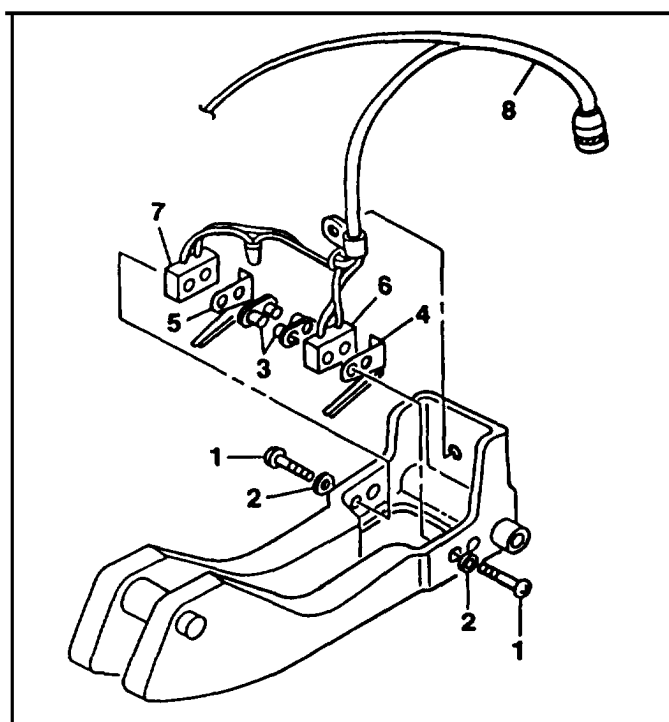
Tool Kit, Aircraft Mechanics,
 NSN 5180-00-323-4692
 Shop Set, Intermediate Maintenance
 NSN 4920-00-472-4183
 Tool Kit, Electrical Repairer
 NSN 5180-00323-4915

References:

None

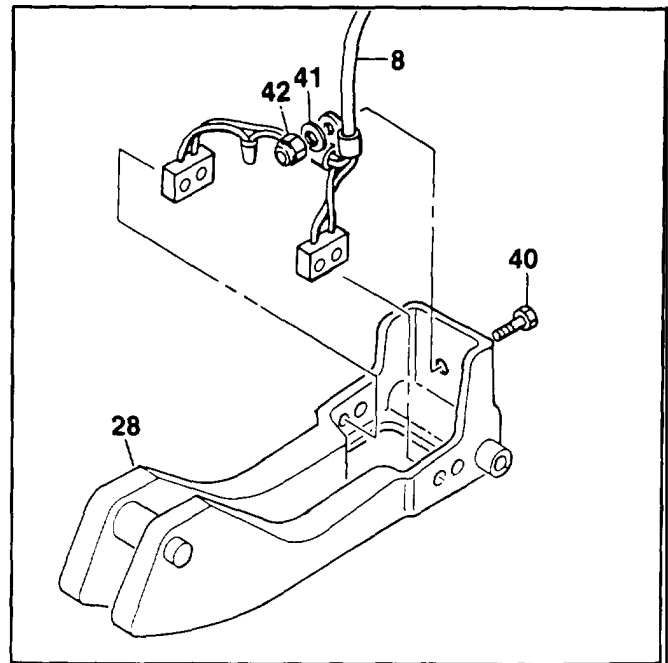
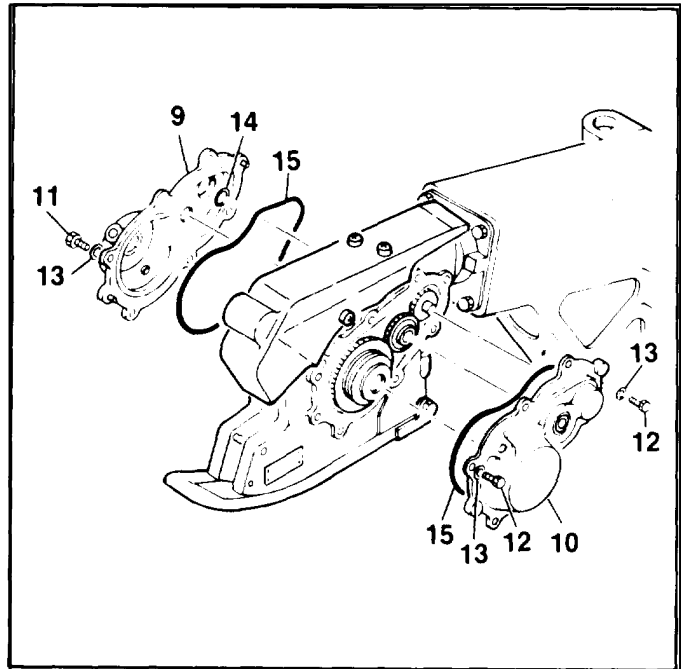
1. Removal.

- a. Remove screws (1), washers (2) and nutplate assemblies (3).
- b. Carefully remove actuator leaves (4, 5) from microswitch assemblies (6, 7) on wiring harness assembly (8).

GO TO NEXT PAGE

3-24. MICROSWITCH ASSEMBLY (PULL UP) - REPLACE (cont)

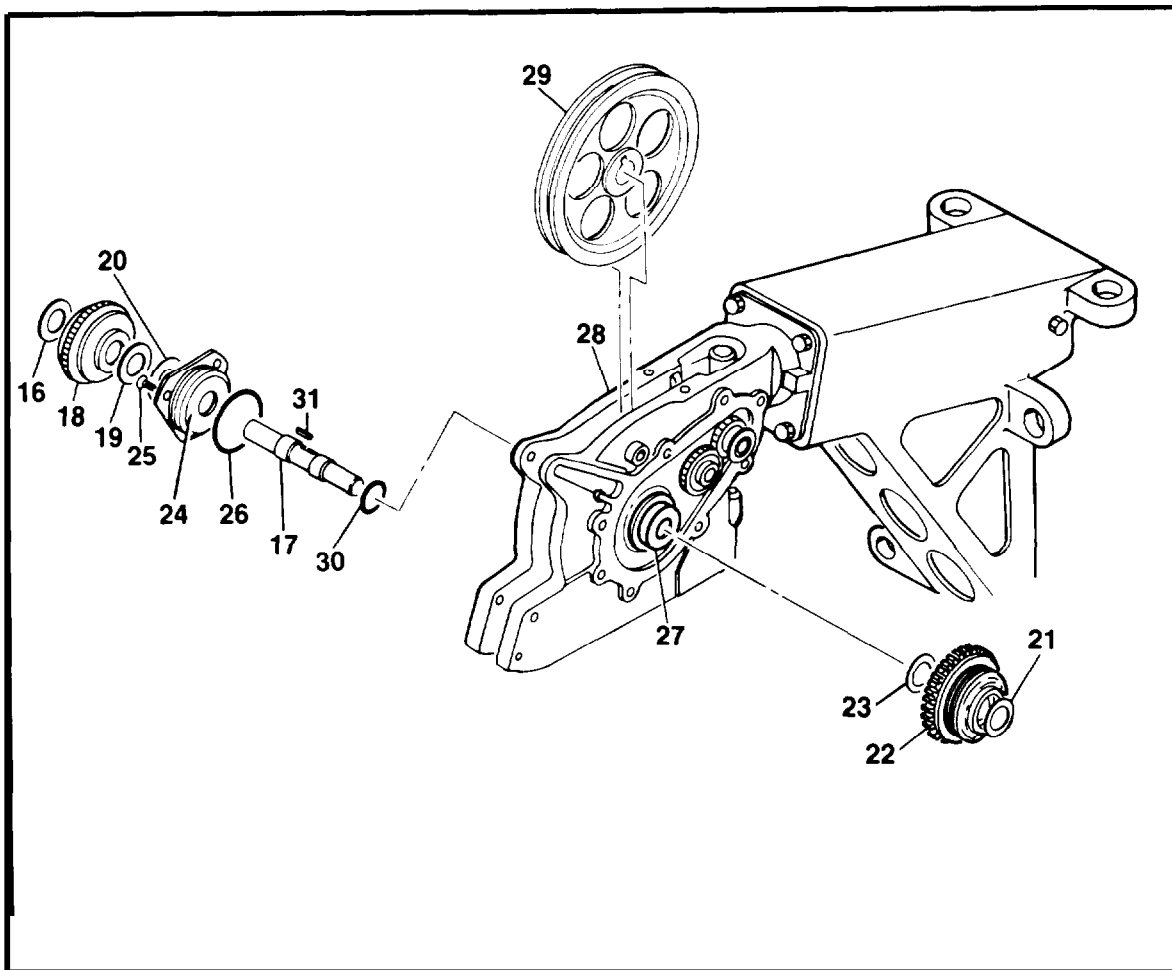
- c. Remove side cover assemblies (9, 10) by removing bolts (11, 12) and washers (13). Remove shim (14) from bearing bore of cover.
- d. Remove and discard packings (15) from covers (9, 10).
- e. Remove thrust washer (16) from sheave shaft (17). Rotate clutch assembly (18) and remove. Remove thrust washer (19). Remove and retain shim (20) if installed,
- f. Remove thrust washer (21) from sheave shaft (17), Rotate brake assembly (22) and remove. Remove thrust washer (23).
- g. Remove retainer assembly (24) by removing screws (25). Remove and discard packing (26).
- h. Remove sheave shaft (17) from bearing (27) in main housing assembly (28). Slide sheave assembly (29) out through top of main housing assembly.
- i. Remove packing (30) and machine key (31) from sheave shaft (17). Discard packing,
- j. Remove clamp (32) by removing bolt (33), washer (34) and nut (35).
- k. Remove wiring harness (8) from main housing assembly (28) by removing bolt (40), washer (41) and nut (42).



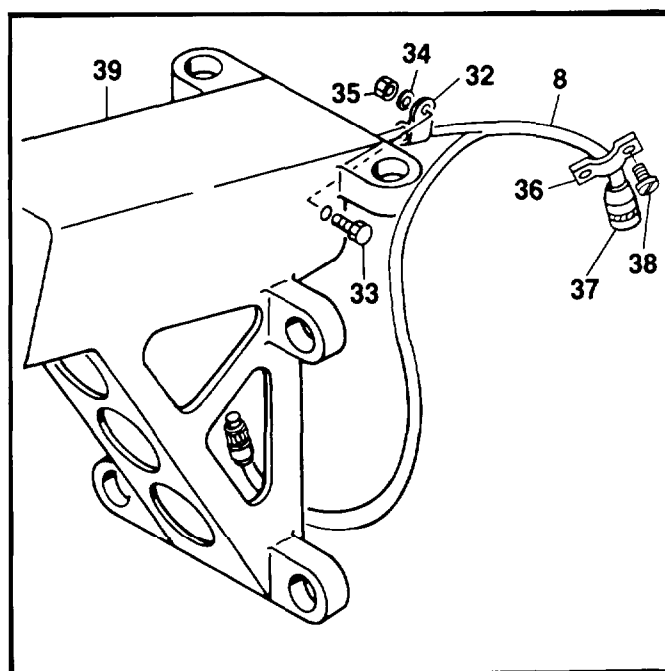
GO TO NEXT PAGE

3-24. MICROSWITCH ASSEMBLY (FULL UP) - REPLACE (cont)

3-24



- l. Remove clamp (36) horn connector (37) by removing screws (38).
- m. Remove heat shrink tubing and electrical brai from wiring harness (6).
- n. Unscrew connector shell horn connector (37). Slide shell and insulator away from connector. Remove pins from connector using a suitable pin removal tool.
- o. Carefully pull wiring harness (6) through boom head assembly (39) from actuator end of housing.



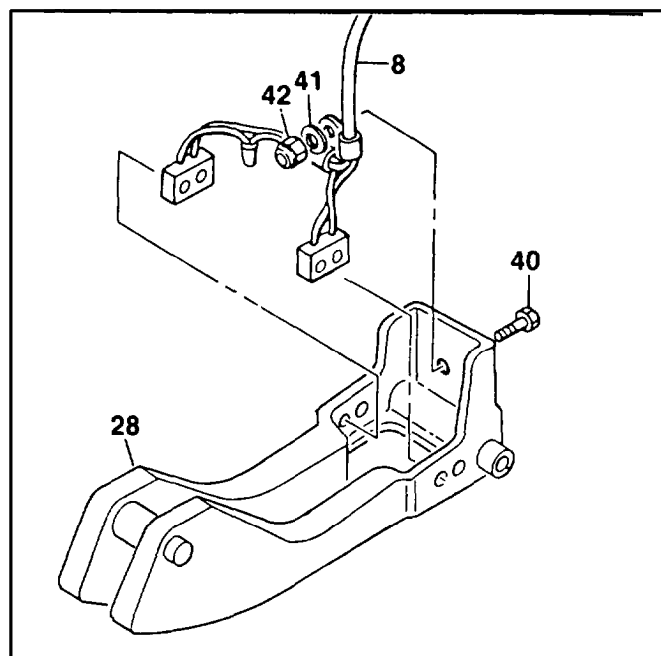
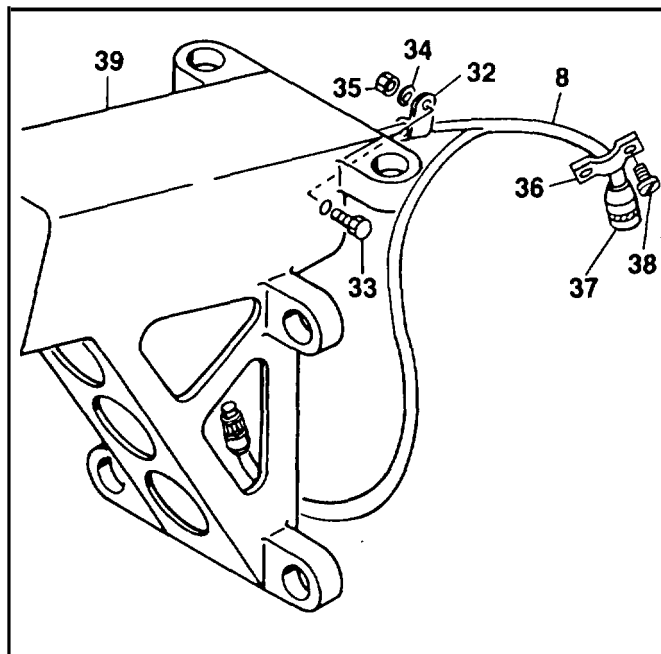
GO TO NEXT PAGE

3-24. MICROSWITCH ASSEMBLY (FULL UP) - REPLACE (cont)

3-24

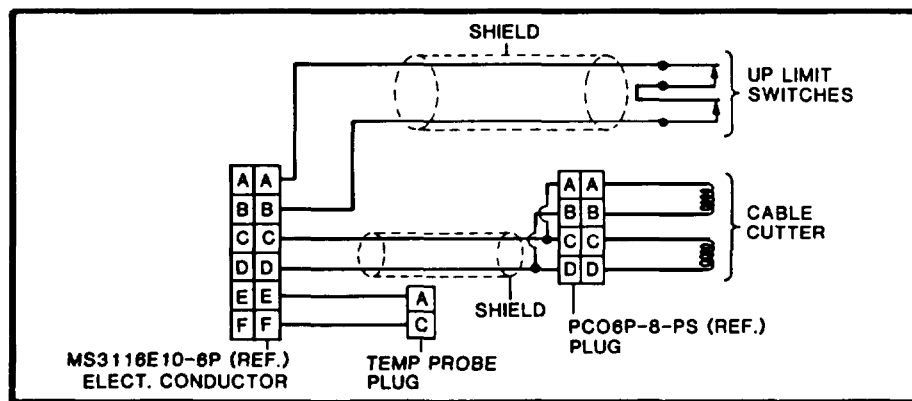
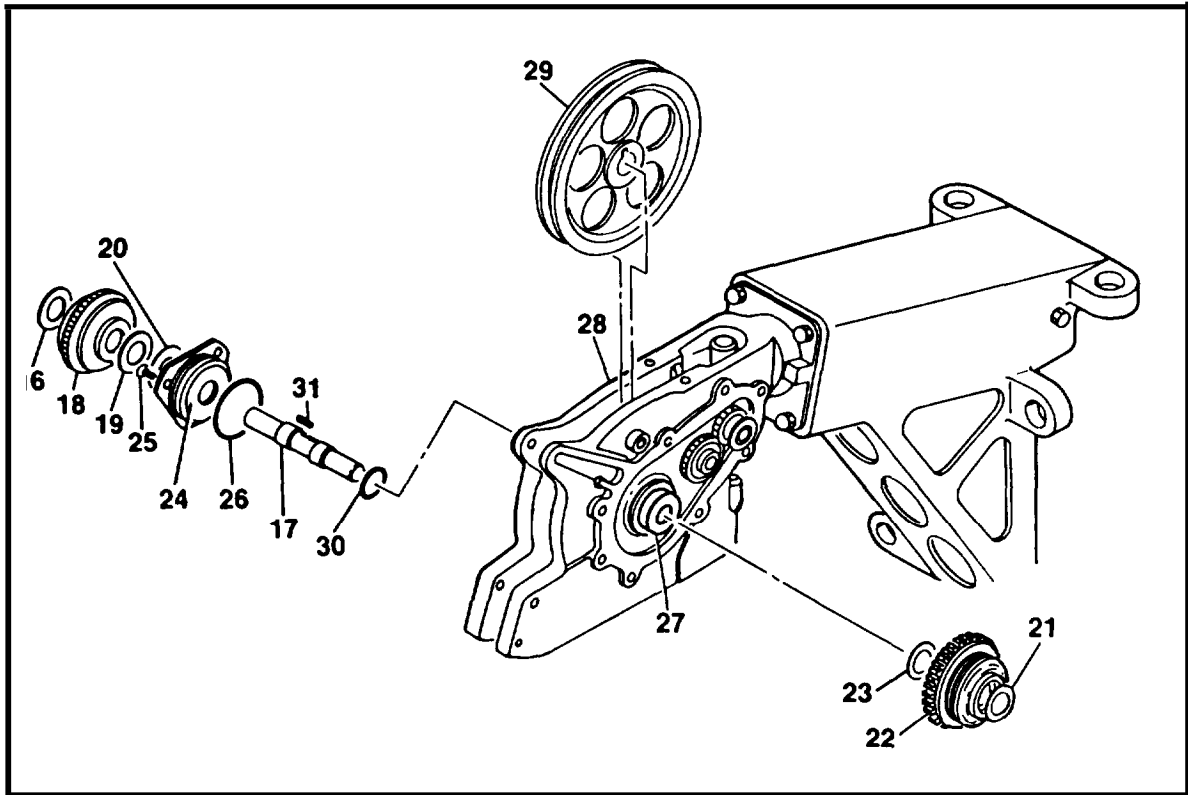
2. Installation.

- a. Place electrical braid over both leads of actuator assembly. Route shielded leads through access hole in boom head housing (39).
- b. Install wiring harness assembly (8) to main housing assembly (28) using bolt (40), washer (41) and nut (42).
- c. Slide approximately 10 inches (25.4 cm) of heat shrink tubing over cable cutter and actuator wires until it butts against housing. Shrink tubing in place.
- d. Slide connector shell and insulator, approximately 5 inches (12.7 cm) of heat shrink tubing, and 3 inches (7.62 cm) of electrical braid onto wire harness (8).
- e. Install pins into connector (37) in accordance with wiring diagram.
- f. Assemble connector (37). Slide electrical braid flush with connector and twist braid until secured. Slide heat shrink tubing over braid and shrink in place.
- g. Install clamp (36) onto connector (37) and secure using screws (38).
- h. Secure wire harness (8) to boom head housing (39) using clamp (32), bolt (33), washer (34) and nut (35).
- i. Lubricate packing (30). Install machine key (31) and packing on sheave shaft (17).
- j. Slide sheave assembly (29) through top of main housing assembly (28) and install sheave shaft (17) in main housing assembly so that machine key (31) aligns with corresponding hole in sheave assembly and sheave shaft locks in place. Remove or install shims adjacent to bearing (27) to achieve **0.003-0.010 in. (0.008-0.025 cm) end play** of sheave. Ensure **sheave is centered within 0.010 in. (0.025 cm) of main housing assembly centerline.**

**GO TO NEXT PAGE**

3-24. MICROSWITCH ASSEMBLY (FULL UP) - REPLACE (cont)

- k. Lubricate packing (26) and install on retainer assembly (24).
- l. Install retainer assembly (2A) on main housing assembly (28) and secure using screws (25).
- m. Install thrust washer (23) on sheave shaft (17). Install brake assembly (22) with spring end out on sheave shaft and rotate brake assembly to lock in place. Install thrust washer (21) on sheave shaft.
- n. Install thrust washer (19) on sheave shaft (17). Install clutch assembly (18) with spring end out on sheave shaft and rotate clutch to lock in place. Install thrust washer (16) on sheave shaft.

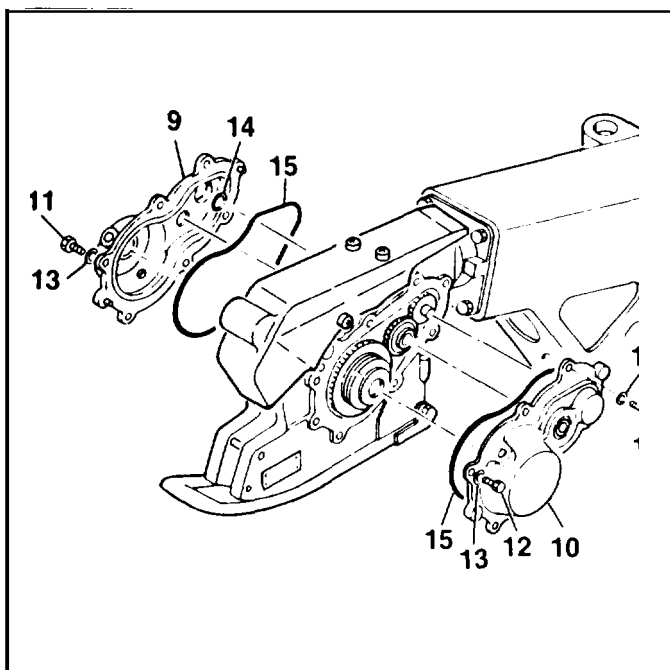


GO TO NEXT PAGE

3-24. MICROSWITCH ASSEMBLY (FULL UP) - REPLACE (cont)

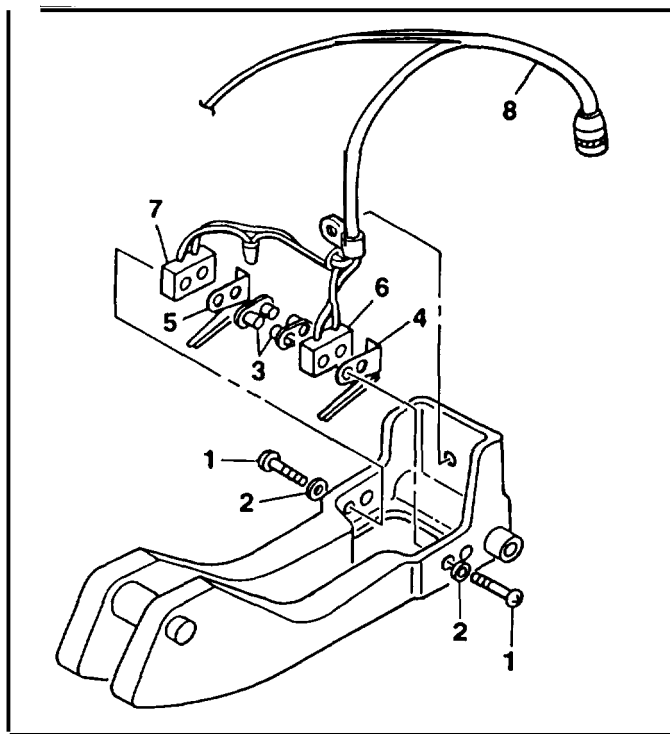
3-24

- o. Lubricate side cover packings (15) and install on side cover assemblies (11).
- p. Install side cover assemblies (11) and secure using bolts (12) and washers (13). **Torque bolts to 20-25 in-lbs.**
- q. Install actuator leaves (4) and position with microswitch assemblies(5) into boom housing. Secure using screws (1), washers (2) and nutplates (3).



FOLLOW-ON MAINTENANCE:

- Install boom head assembly (Task 2-20)
- Install actuator assembly (Task 2-25)
- Test microswitch assemblies (Task 2-26)



END OF TASK

3-25. FLEXIBLE DRIVESHAFT ASSEMBLY - INSPECT**3-25****This task covers: Inspection****INITIAL SETUP****Personnel Required:**

67N, UH1 Helicopter Repairer
 67T, UH60 Helicopter Repairer
 91W, Medevac Medics

Equipment Condition:

Hoist installed in assembly stand
 Flexible driveshaft removed

Parts/Materials:

None

Equipment Condition Para:

Task 3-5
 Task 3-26

Tools and Test Equipment:

None

Reference

None

1. Inspect all parts for nicks, cracks, scratches and dents (refer to Task 2-11).
2. Inspect worm for damaged threads.
3. Check shaft for smooth rotation without binding.
4. Inspect casing for kinks.

FOLLOW-ON MAINTENANCE:

Replace flexible driveshaft
 (Task 3-26)

END OF TASK

3-26. FLEXIBLE DRIVESHAFT ASSEMBLY - REPLACE

This task covers: Removal and Installation

INITIAL SETUP

Personnel Required:

67N, UH1 Helicopter Repairer
 67T, UH60 Helicopter Repairer
 91W, Medevac Medics

Equipment Condition:

Hoist installed in assembly stand
 Boom head assembly removed

Parts/Materials:

Packing, MS28775-156
 Hydraulic Fluid (Item 13, App. D)

Equipment Condition Para:

Task 3-5
 Task 2-20

Tools and Test Equipment:

Tool Kit, Airmail Mechanics,
 NSN 5180-00-323-4692
 Shop Set, Intermediate Maintenance
 NSN 4920-00-472-4183

References:

None

1. Removal.

- a. Remove side cover assembly (1) by removing bolts (2) and washers (3). Remove shim (4) from bearing bore of cover.
- b. Remove and discard packing (5) from cover (1).
- c. Remove lockwire from retaining screw (6) and discard. Remove screw, releasing flexible drive shaft (7).
- d. Remove clamp (8) by removing nut (9), washer (10) and bolt (11). Pull flexible drive shaft (7) from boom head.

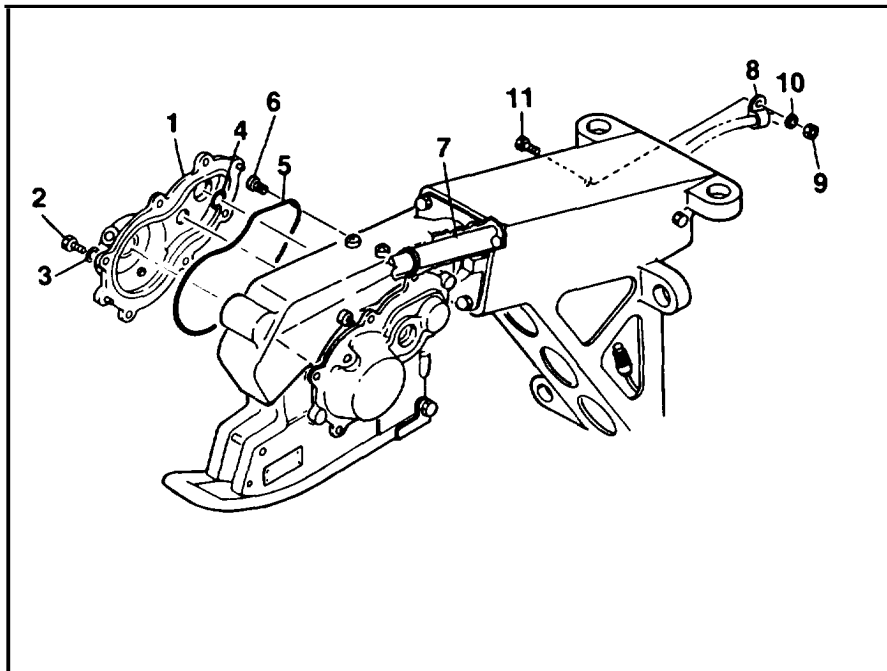
2. Installation.

- a. Install flexible drive shaft (7) so that shaft bottoms out in boom head assembly, and worm of shaft is visible in boom head housing.
- b. Secure flexible drive shaft (7) using retaining screw (6) Safety wire screw to side housing when installed using lockwire.
- c. Install clamp (8) using nut (9), washer (10) and bolt (11).

GO TO NEXT PAGE

3-26. FLEXIBLE DRIVESHAFT ASSEMBLY - REPLACE (cont)

3-26

**NOTE**

Release spring tension in pressure roller and rotate flexible drive shaft (7) to ensure smooth operation, free of binding.

- d. Install shim (4) into bearing bore of side cover (1).
- e. Lubricate side cover packing (5) and install on side cover assembly (1).
- f. Install side cover assembly (1) and secure using bolts (2) and washers (3). **Torque bolts to 20-25 in-lbs.**

FOLLOW-ON MAINTENANCE:

Install boom head assembly
(Task 2-20)

END OF TASK

3-27. CONTROL PANEL ASSY - REPAIR

3-27

This task covers: Repair

INITIAL SETUP

Personnel Required:

67N, UH1 Helicopter Repairer (2)
67T, UH60 Helicopter Repairer (2)
68F, Aircraft Electrical Repairer
91W, Medevac Medics

Equipment Condition:

Hoist installed in assembly stand
Control panel removed

Parts/Materials:

None

Equipment Condition Para:

Task 3-5
Task 2-27

Tools and Test Equipment:

None

References

None

Repair of control panel assembly consists of removal and replacement of blower/DC motor assembly (refer to Task 3-28 for procedures).

FOLLOW-ON MAINTENANCE:

None

END OF TASK

3-28. BLOWER ASSY/DC MOTOR - REPLACE**3-28**

This task covers: Removal and Installation

INITIAL SETUP**Personnel Required:**

67N, UH1 Helicopter Repairer (2)
 67T, UH60 Helicopter Repairer (2)
 68F, Aircraft Electrical Repairer
 91W, Medevac Medics

Equipment Condition:

Hoist installed in assembly stand
 Control panel removed

Parts/Materials:

None

Equipment Condition Para:

Task 3-5
 Task 2-27

Tools and Test Equipment:

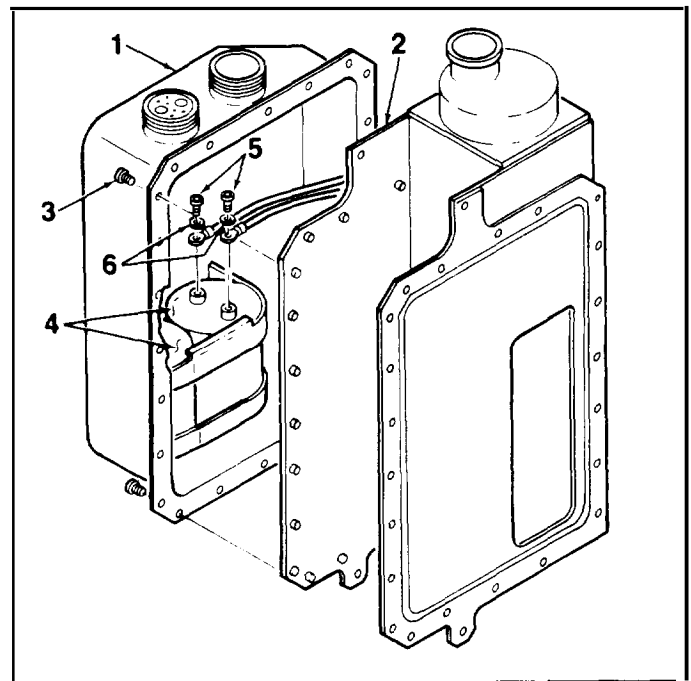
Tool Kit, Aims.ft Mechanics
 NSN 5180-00-323-4692
 Shop Set, Intermediate Maintenance
 NSN 4920-00-472-4183
 Tool Kit, Electrical Repairer
 NSN 5180-00-323-4915

References:

Aircraft Electric and Electronic Wiring
 TM 55-1500-323-24

1. Removal.

- a. Remove control panel cover (1) from control panel (2) by removing screws (3).
- b. Disconnect electrical wiring from capacitors (4) by removing nuts (5) and washers (6). Unsolder wiring braid from control panel.



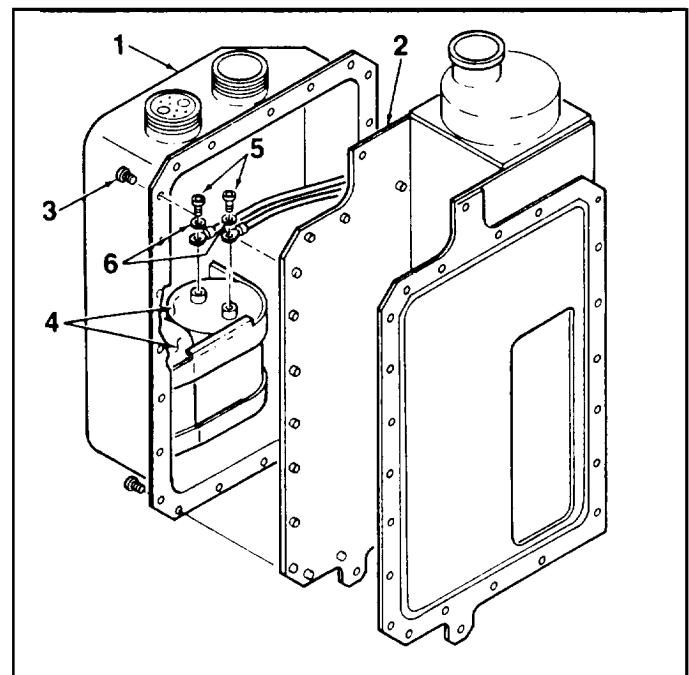
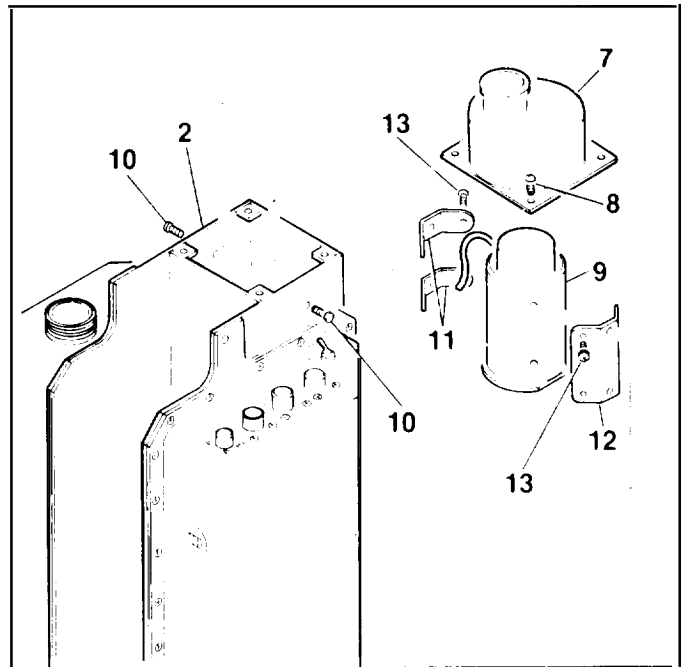
GO TO NEXT PAGE

3-28. BLOWER ASSY/DC MOTOR - REPLACE (cont)

- c. Remove fan assembly plenum (7) by removing screws (8).
- d. Remove blower /DC motor assembly (9) from control panel (2) by removing screws (10).
- e. Remove brackets (11, 12) from blower/DC motor assembly (9) by removing screws (13).

2. Installation.

- a. Install brackets (11, 12) onto blower / DC motor assembly (9) and secure using screws (13).
- b. Feed wiring through hole in control panel (2) while lowering blower / DC motor assembly (9) onto control panel. Secure using screws (10).
- c. Solder wire braid to control panel (2).
- d. Install fan assembly plenum (7) and secure using screws (8).
- e. Connect electrical wiring to capacitors (4) using nuts (5) and washers (6).
- f. Install control panel cover (1) to control panel (2) and secure using screws (3).



FOLLOW-ON MAINTENANCE:

- Install control panel
(Task 2-27)
- Conduct operational check
(Task 3-7)

END OF TASK

3-29. BOOM POSITION SUPPORT ASSY - REPAIR**3-29**

This task covers Disassembly, Cleaning, Inspection, Repair and Reassembly

INITIAL SETUP**Personnel Rewired:**

67N, UH1 Helicopter Repairer (2)
 67T, UH60 Helicopter Repairer (2)
 68F, Aired Electrical Repairer
 91W, Medevac Medics

Parts/Materials:

Cleaning Solvent (Item 10, App.D)
 Packing, MS28775-133
 Petrolatum (Item 19, App. D)

Tools and Test Equipment:

Tool Kit, Aircraft Mechanics
 NSN 5180-00-323-4692
 Shop Set, Intermediate Maintenance
 NSN 4920-(W472-4183
 Tool Kit, Electrical Repairer
 NSN 5180-0(L323-4915
 Air source, 35 psi

Equipment Condition:

Hoist installed in assembly stand
 Boom position support assembly removed

Equipment Condition Para:

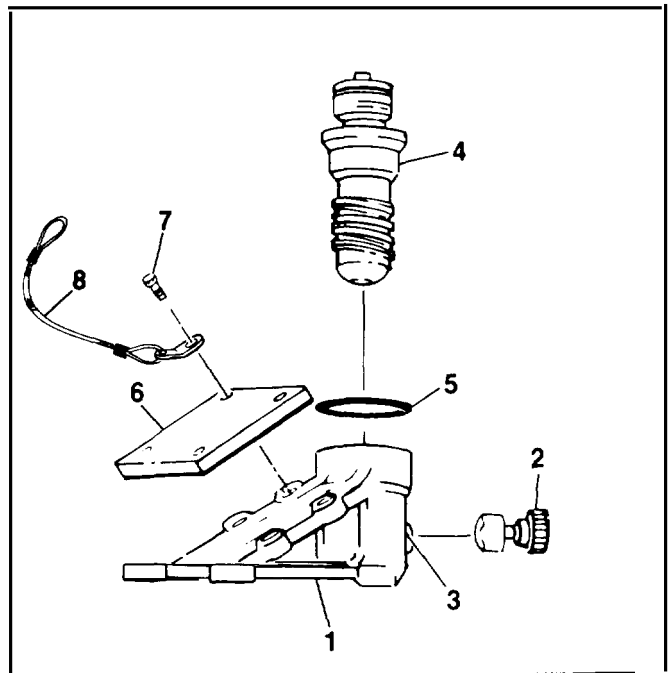
Task 3-5
 Task 3-30

References:

Avionic Cleaning and Corrosion Prevention/Control
 TM 55-1500-343-23
 Aircraft Electric and Electronic Wiring
 TM 55-1500-323-24

1. Disassembly.

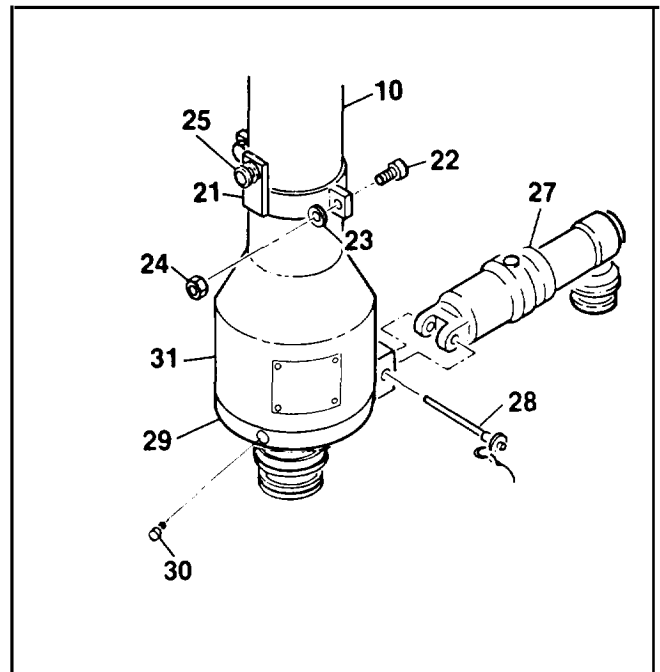
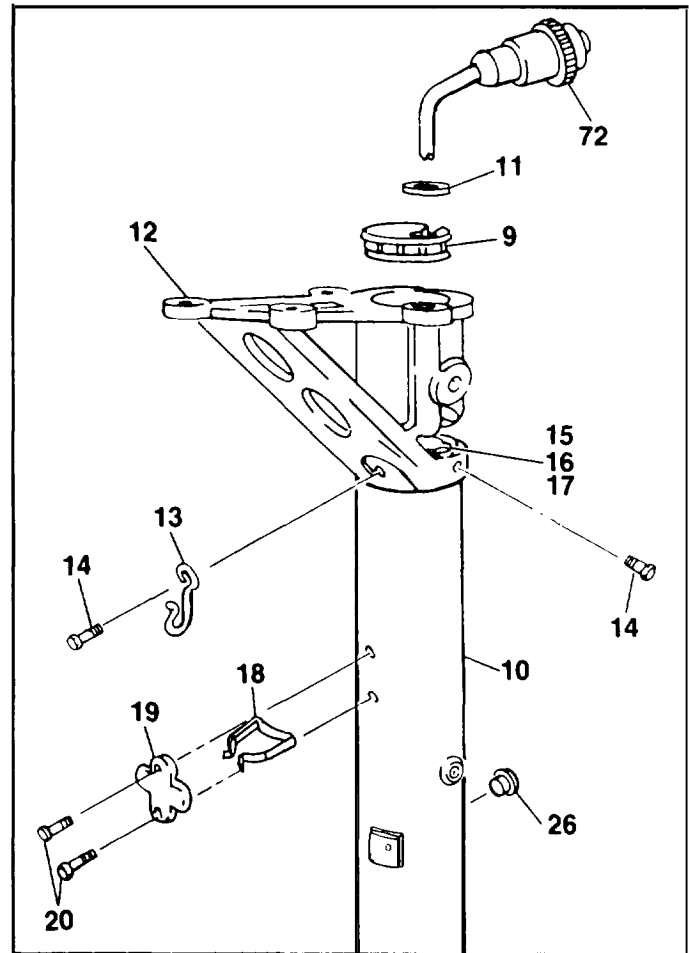
- a. Remove plunger (2) from upper support assembly (1) by removing setscrew (3).
- b. Unscrew height adjuster assembly (4) from upper support assembly (1). Remove and discard packing (5).
- c. Remove cover (6) and lanyard (7) by removing screws (8).



GO TO NEXT PAGE

3-29. BOOM POSITION SUPPORT ASSY - REPAIR (cont)

- d. Remove stanchion cover plate (9) from stanchion tube (10). Push grommet (11) from cover plate.
- e. Remove lower support assembly (12) and hook (13) by removing screws (14).
- f. Remove nut-anchor (15) and ring (16), if required by removing rivets (17).
- g. Remove spring (18) and retainer-hook (19) from stanchion tube (10) by removing screws (20).
- h. Remove stud ring (21) from stanchion tube (10) by removing bolts (22), washers (23) and nuts (24). Remove stud (25).
- i. Remove plug (26) from stanchion tube (10).
- j. Disconnect reaction arm assembly (27) from stanchion tube (10) by removing pin (28).
- k. Remove ring (29) by removing screws (30). Slide switch cover (31) up stanchion tube (10).

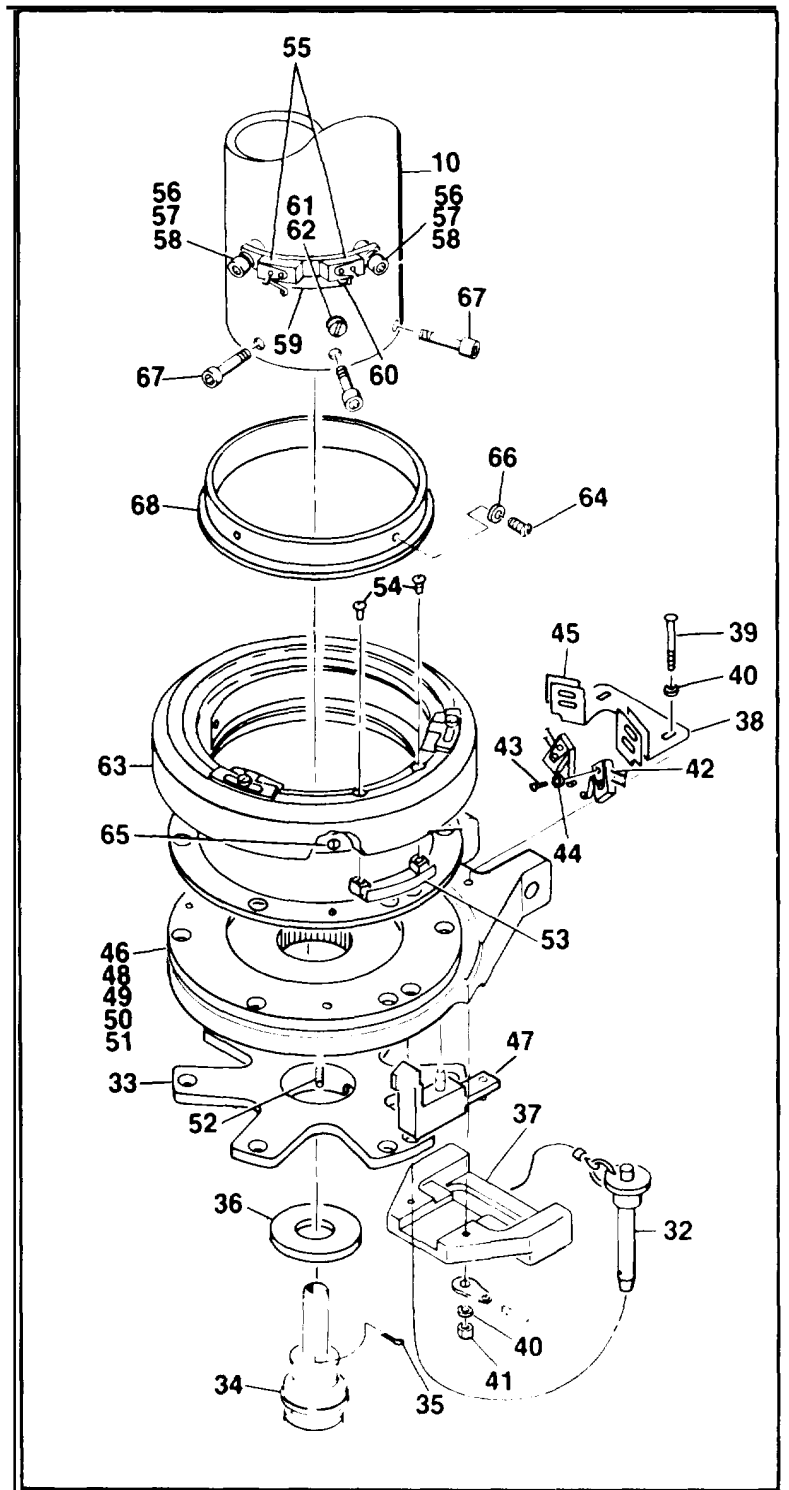


GO TO NEXT PAGE

3-29. BOOM POSITION SUPPORT ASSY - REPAIR (cont)

3-29

- l. Remove pins (32) from lower base plate (33).
- m. Remove quick disconnect (34) by removing cotter pin (35). Discard cotter pin. Remove washer (36) and lower base plate (33).
- n. Remove plate (37) and overload bracket (38) by removing screws (39), washers (40) and nuts (41). Remove pins (32).
- o. Remove limit switches (42) from bracket (38) by removing screws (43), washers (44) and nutplates (45).
- p. Remove reaction plate assembly (46) and lever (47). Disassemble plate assembly, if required, by removing plate (48), bushing (49), pin (50), mounting flange (51) and insert (52).
- q. Remove clamp (53) by removing screws (54).
- r. Remove limit switches (55) by removing screws (56), washers (57) and spacers (58).
- s. Remove clamp (59) by removing screws (60). Disconnect electrical wiring from connector P4 (72) and flexible wiring harness. Remove screw (61) and washer (62).
- t. Remove cam support (63) by removing screws (64, 65) and washers (66). Remove bolts (67) and slide cam support cover (68) off stanchion tube (10).



GO TO NEXT PAGE

- u. Remove flexible wiring harness (69) from cam support (63) by removing screw (70) and washer (71). Pull harness from support.

2. Cleaning.

WARNING

Use solvent in a well-ventilated area. Avoid prolonged breathing of fumes. Keep away from open flame. Solvent is flammable.

WARNING

Use approved personal protective equipment (goggles/face shield) when using compressed air. Air pressure is restricted to a maximum of 35 psi. Do not direct airstream towards self or other personnel.

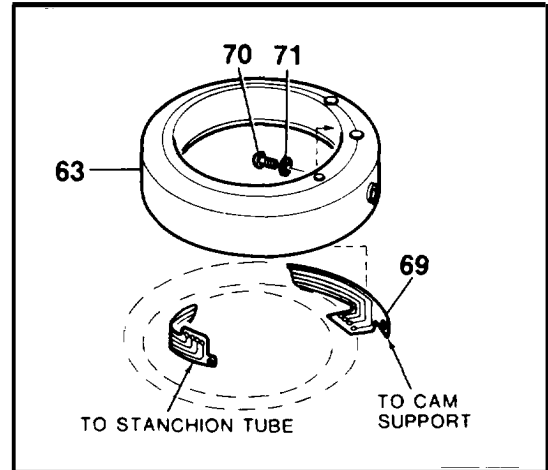
CAUTION

Do not immerse electrical components in cleaning solvent. Wipe clean with a cloth dampened in soap and water solution.

CAUTION

If parts are not to be inspected immediately after cleaning, dip them in preservation oil to prevent rust spots.

- a. Clean electrical contact pins in accordance with procedures outlined in TM 55-1500-343-23.
- b. Clean electrical components by wiping clean with cloth dampened in trichloromethane. Wipe with a clean, dry cloth and allow to air dry.
- c. Wash remaining components in solvent and rinse thoroughly. Dry with compressed air.



GO TO NEXT PAGE

3-29. BOOM POSITION SUPPORT ASSY - REPAIR (cont)**3-29****3. Inspection.**

- a. Inspect all parts for nicks, cracks, scratches and dents (refer to Task 2-11).
- b. Inspect for corrosion (refer to Task 2-11).
- c. Inspect all threaded parts for crossed, stripped and damaged threads.
- d. Inspect electrical wiring for frayed and broken insulation. Check for cuts and tears.
- e. Inspect electrical connectors for bent, broken and missing pins. Inspect for evidence of overheating and shorting.
- f. Inspect identification plates for legibility and security of attachment.
- g. Inspect hook and pendant spring for damage.

4. **Repair.** Repair of parts is limited to removal of minor nicks, burrs, scratches or other surface damage using aluminum oxide cloth or fine abrasive. Clean part thoroughly after repair. If damage is extensive, or if minor repair will affect serviceability, replace the part.

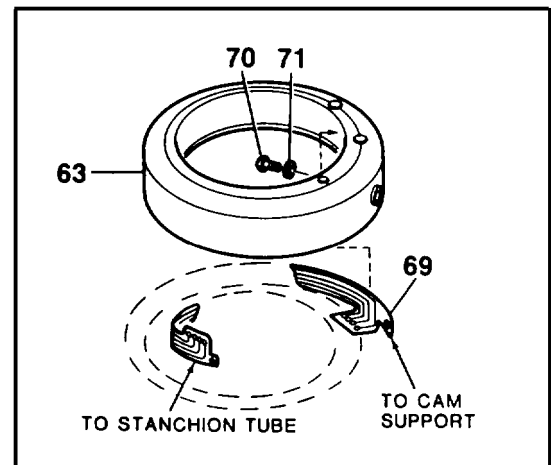
5. Reassembly.

- a. Position flexible wiring harness (69) into cam support (63).

NOTE

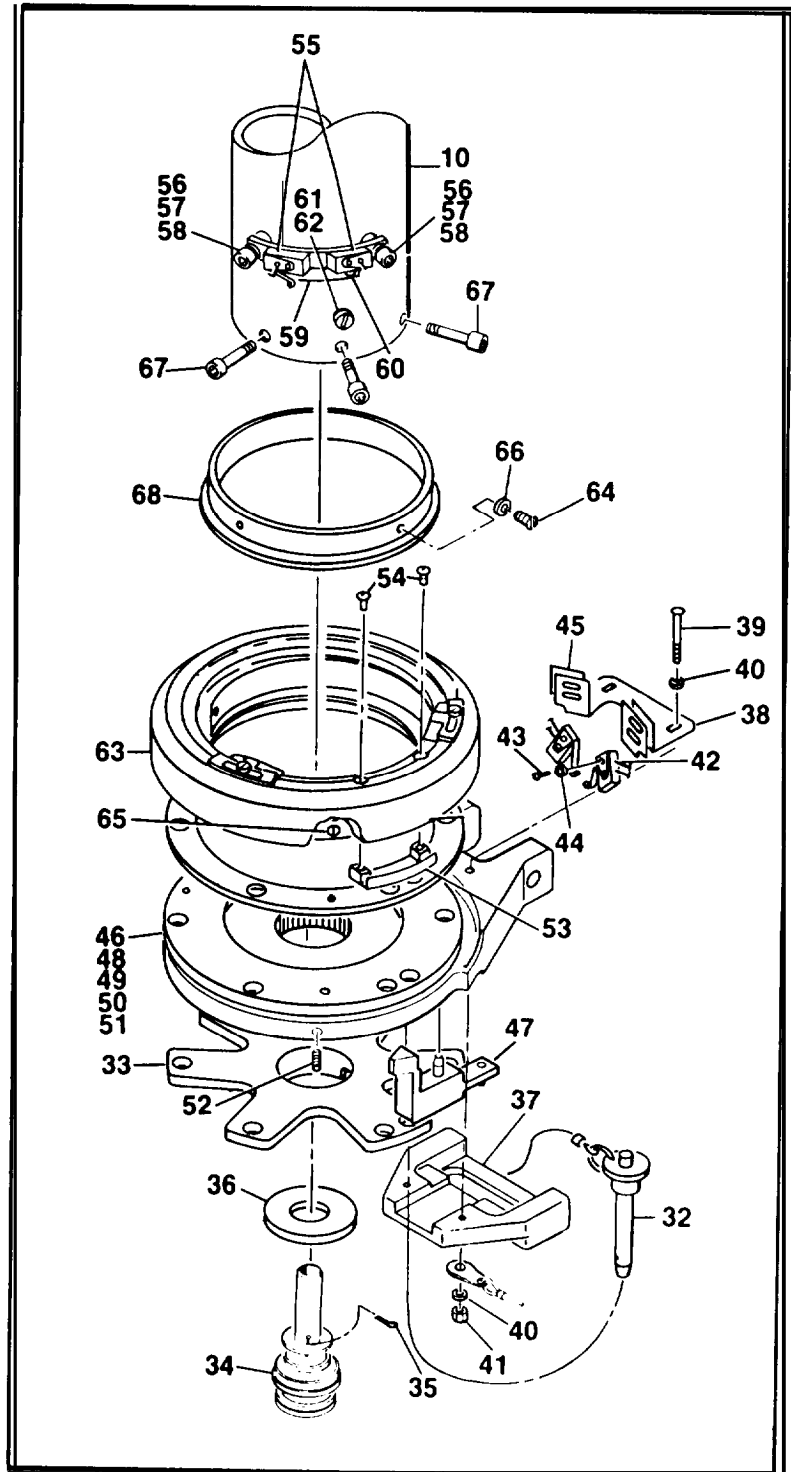
Wiring harness will spiral inside cam support for 2.5 revolutions. Ensure harness lays flat before securing.

- b. Secure one end of wiring harness (69) to cam support (63) using screw (70) and washer (71).

**GO TO NEXT PAGE**

3-29. BOOM POSITION SUPPORT ASSY - REPAIR (cont)

- c. Slide cam cover (68) and cam support (63) onto stanchion tube (10). Install bolts (67).
- d. Connect electrical wiring from connector P4 (72) and remaining end of flexible wiring harness (69) to stanchion tube (10) using screw (61) and washer (62).
- e. Install clamp (59) to stanchion tube (10) using screws (60).
- f. Secure cam support (63) and cover (68) to stanchion tube (10) using screws (64, 65) and washers (66).
- g. Install limit switches (55) using screws (56), washers (57) and spacers (58). Safety wire screws.
- h. Attach wiring harness (69) to limit switches (42). Install clamp (53) using screws (54).
- i. Assemble reaction plate assembly (46) by installing inserts (52), mounting flange (51), pin (50), bushing (49) and plate (48). Install reaction plate assembly and lever.
- j. Install limit switch actuators and limit switches (42) onto overload bracket (38) and secure using screws (43), washers (44) and nutplates (45).
- k. Install plate (37) and overload bracket (38). Attach pins (32) using screws (39), washers (40) and nuts (41).
- l. Install lower base plate (33), washer (36) and quick disconnect (34). Secure by installing cotter pins (35),
- m. Install pin (32) through lower base plate (33).

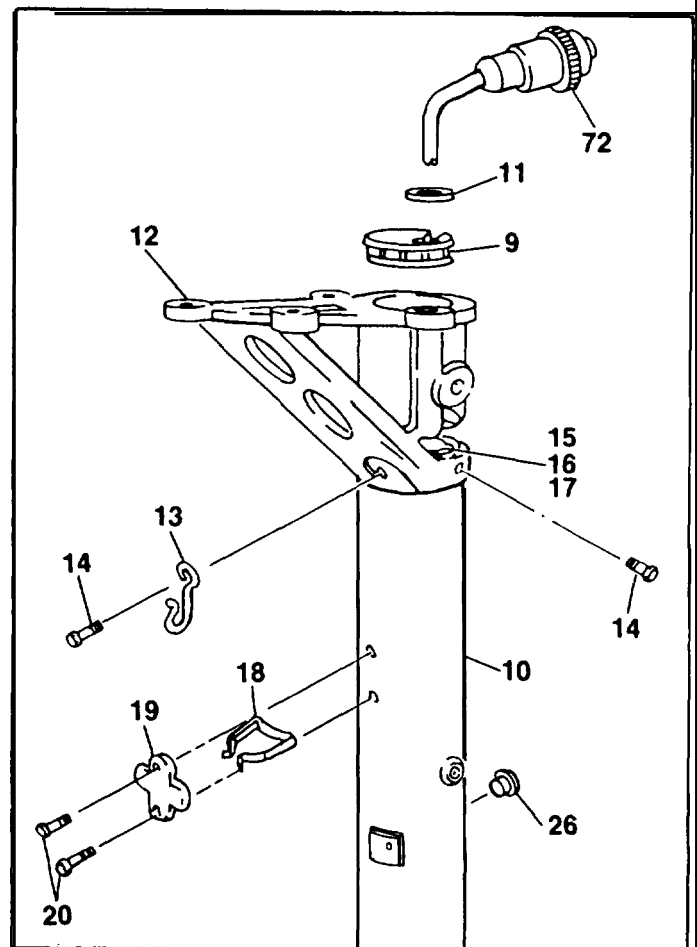
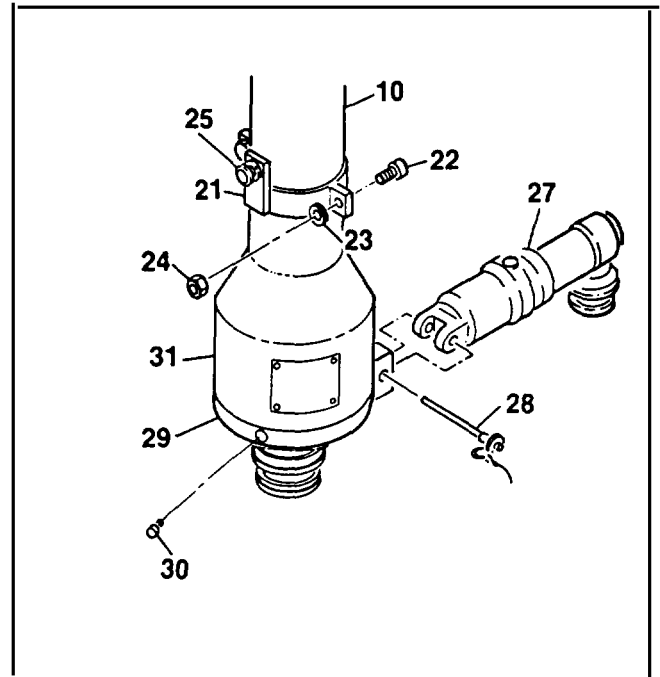


GO TO NEXT PAGE

3-29. BOOM POSITION SUPPORT ASSY - REPAIR (cont)

3-29

- n. Install cover (31) and ring (29) and secure using screws (30).
- o. Install plug (26) into stanchion tube (10).
- p. Install stud ring (21) onto stanchion tube (10) and secure using bolts (22), washers (23) and nuts (24).
- q. Attach reaction arm assembly (27) to stanchion tube (10) and secure using pin (28).
- r. Install spring (18) and tetainer-hook (19) onto stanchion tube (10) and secure using screws (20).
- s. Install nut-anchor (15) and ring (16) and secure using rivets (17).
- t. Install support assembly (12) and hook (13) and secure using screws (14).
- u. Install grommet (11) into cover plate (9). Install cover plate onto stanchion tube (10).



GO TO NEXT PAGE

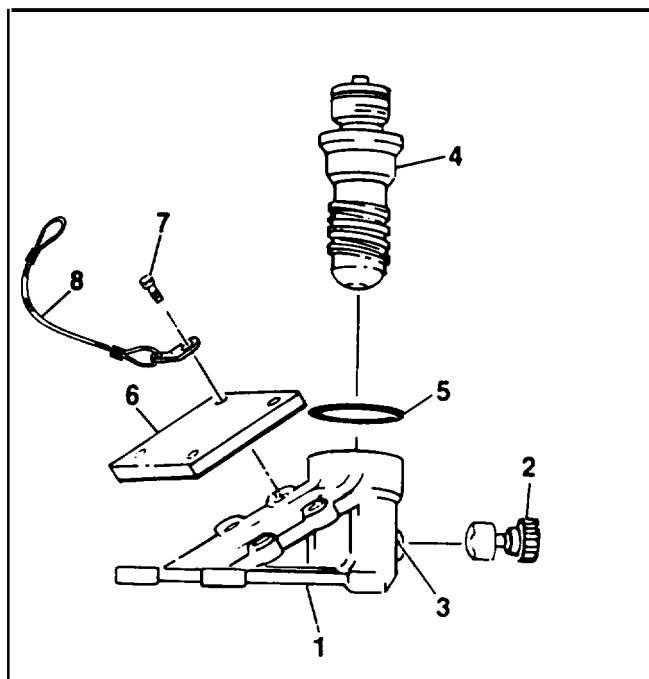
3-29. BOOM POSITION SUPPORT ASSY - REPAIR (cont)

3-29

- v. Install cover (6) and lanyard (7) onto upper support assembly (1) and secure using screws (8).
- w. Lubricate packing (5) and install. Install adjuster (4).
- x. Install plunger (2) and secure using setscrew (3).

FOLLOW-ON MAINTENANCE:

Install boom position support assembly
(Task 3-30)

**END OF TASK**

3-30. BOOM POSITION SUPPORT ASSY - REPLACE**3-30**

This task covers: Removal and Installation

INITIAL SETUP**Personnel Rewired:**

67N, UH1 Helicopter Repairer
 67T, UH60 Helicopter Repairer
 91W, Medevac Medics

Equipment Condition:

Hoist placed on suitable work bench

Parts/Materials:

None

Equipment Condition Para:

None

Tools and Test Equipment:

None

References:

None

1. Removal.

- a. Remove the control panel assembly in accordance with Task 2-27.
- b. Remove the winch assembly in accordance with Task 3-37.

2. Installation.

- a. Install the winch assembly in accordance with Task 3-37.
- b. Install the control panel assembly in accordance with Task 2-27.

FOLLOW-ONMAINTENANCE:

None

END OF TASK

3-31. UPPER SUPPORT ASSY - REPLACE

This task covers: Removal and Installation

INITIAL SETUP

Personnel Required:

67N, UH1 Helicopter Repairer
 67T, UH60 Helicopter Repairer
 91W, Medevac Medics

Equipment Condition:

Hoist placed on suitable work bench

Parts/Materials:

Packing, MS28775-133
 Petrolatum (Item 19, App. D)

Equipment Condition Para:

None

Tools and Test Equipment:

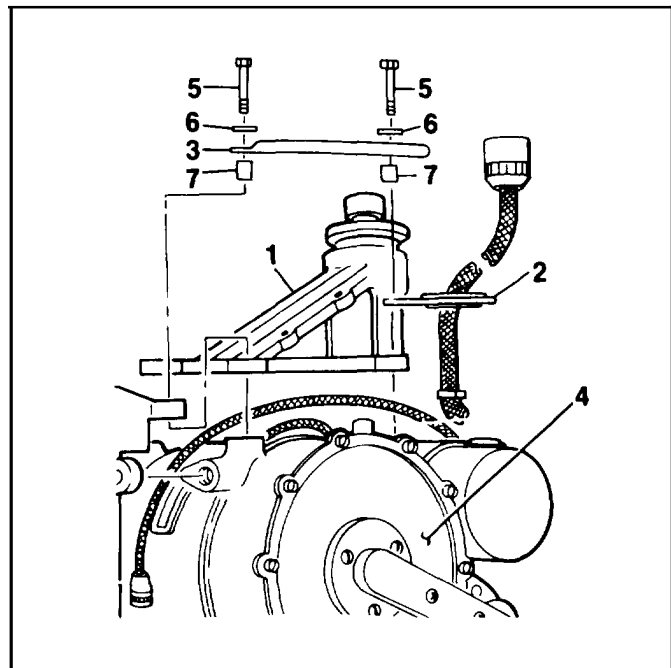
Tool Kit, Aircraft Mechanics
 NSN 5180-00-323-4.692
 Shop Set, Intermediate Maintenance
 NSN 4920-00-472-4183

Reference

None

1. Removal.

- a. Remove upper support (1), bracket (2) and handle (3) from winch assembly (4) by removing bolts (5), washers (6) and spacers (7).



GO TO NEXT PAGE

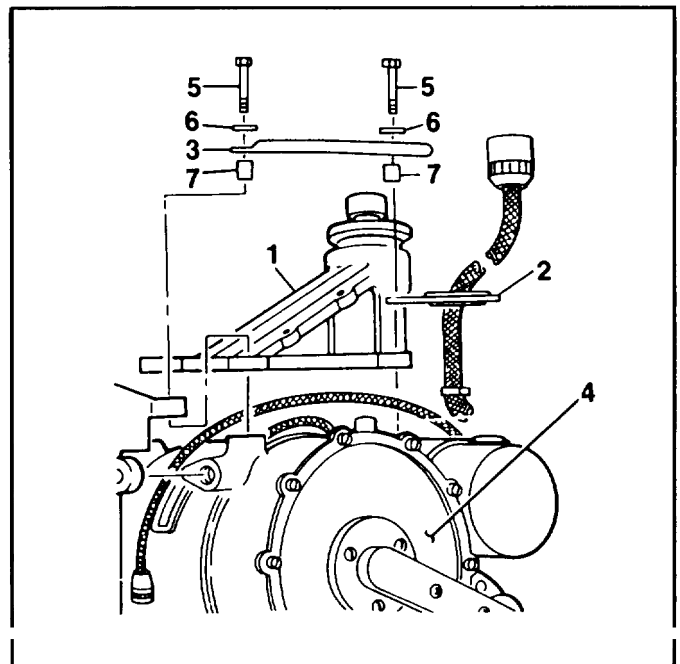
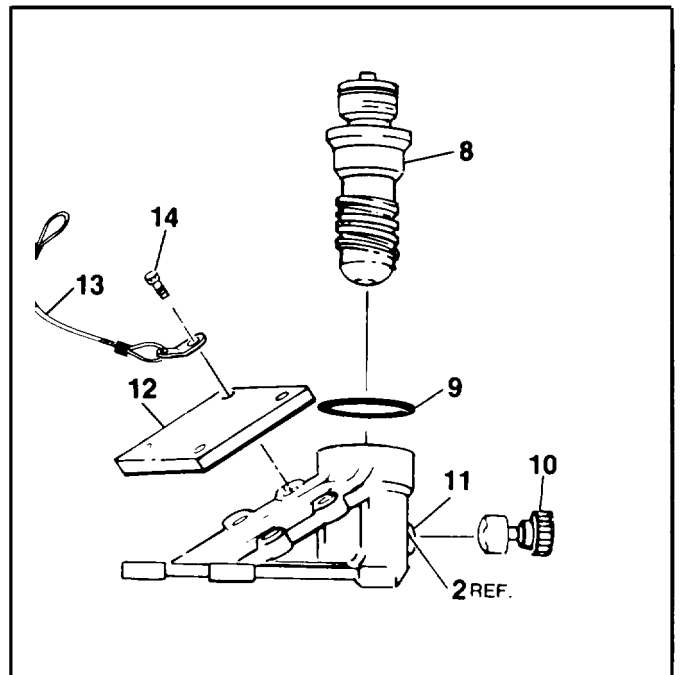
3-31. UPPER SUPPORT ASSY - REPLACE (cont)

3-31

- b. Remove adjuster (8) from upper support (1).
Remove and discard packing (9).
- c. Remove plunger (10) by removing setscrew (11).
- d. Remove plate (12) and lanyard (13) by removing screws (14).

2. Installation.

- a. Install plate (12) and lanyard (13) and secure using screws (14).
- b. Install plunger (10) and secure using setscrew (11).
- c. Lubricate packing (9) and install. Install adjuster (8) onto upper support (1).
- d. Install upper support (1), bracket (2) and handle (3) and secure onto winch assembly (4) using bolts (5), washers (6) and spacers (7).
- e. Torque bolts (4) to 160-190 in.lbs.

**FOLLOW-ON MAINTENANCE:**

None

END OF TASK

3-32. LOWER SUPPORT ASSEMBLY - REPAIR

3-32

This task covers: Repair

INITIAL SETUP**Personnel Required:**

67N, UH1 Helicopter Repairer
67T, UH60 Helicopter Repairer
91W, Medevac Medics

Equipment Condition:

Hoist placed on suitable work bench
Lower support assembly removed

Parts/Materials:

Abrasive Cloth, Aluminum Oxide (Item 1,
App. D)

Equipment Condition Para:

Task 3-5
Task 3-33

Tools and Test Equipment:

None

References:

None

Repair of parts is limited to the removal of minor nicks, burrs, scratches or other surface damage using aluminum oxide cloth or fine abrasive. Clean parts thoroughly after repair. If damage is extensive, or if minor repair will affect serviceability, replace the part.

FOLLOW-ON MAINTENANCE:

Install lower support assembly
(Task 3-33)

END OF TASK

3-33. LOWER SUPPORT ASSEMBLY - REPLACE**3-33****This task covers: Removal and Installation****INITIAL SETUP****Personnel Required:**

67N, UH1 Helicopter Repairer
 67T, UH60 Helicopter Repairer
 91W, Medevac Medics

Equipment Condition:

Hoist placed on suitable work bench
 Boom position support removed

Parts/Materials:

None

Equipment Condition Para:

Task 3-5
 Task 3-30

Tools and Test Equipment:

Tool Kit, Aircraft Mechanics
 NSN 5180-00-323-4692
 Shop Set, Intermediate Maintenance
 NSN 4920-00-472-4183

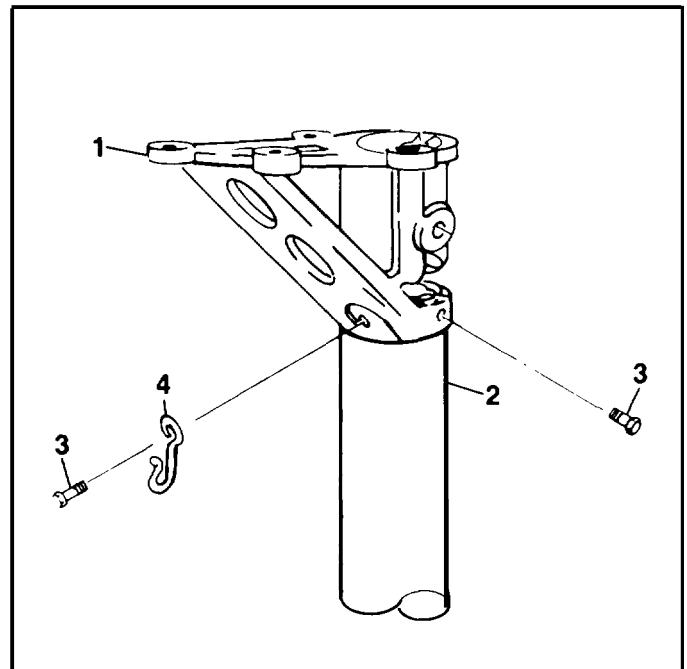
References:

None

1. **Removal.** Remove lower support assembly (1) from stanchion tube assembly (2) by removing screws (3) and hook (4).
2. **Installation.** Install lower support assembly (1) on stanchion tube assembly (2) using screws (3) and hook (4).

FOLLOW-ON MAINTENANCE:

Install boom position support
 (Task 3-30)

**END OF TASK**

3-34. FLEXIBLE WIRING HARNESS - INSPECT

3-34

This task covers: Inspection

INITIAL SETUP**Personnel Required:**

67N, UH1 Helicopter Repairer
67T, UH60 Helicopter Repairer
68F, Aircraft Electrical Repairer
91W, Medevac Medics

Equipment Condition:

Hoist installed in assembly stand
Flexible wiring harness removed

Parts/Materials:

None

Equipment Condition Para:

Task 3-5
Task 3-35

Tools and Test Equipment:

Tool Kit, Aircraft Mechanics
NSN 5180-00-323-4692
Shop Set, Intermediate Maintenance
NSN 4920-00-462-4183

References:

None

-
1. Inspect flexible wiring harness for cuts and tears.
 2. Inspect harness solder connections for damage and security of attachment.

FOLLOW-ON MAINTENANCE:

Replace flexible wiring harness
(Task 3-35)

END OF TASK

3-35. FLEXIBLE WIRING HARNESS - REPLACE

3-35

This task covers: Removal and Installation

INITIAL SETUP**Personnel Required:**

67N, UH1 Helicopter Repairer
 67T, UH60 Helicopter Repairer
 68F, Aircraft Electrical Repairer
 91W, Medevac Medics

Equipment Condition:

Hoist placed on suitable work bench

Parts/Materials:

None

Equipment Condition Para:

None

Tools and Test Equipment:

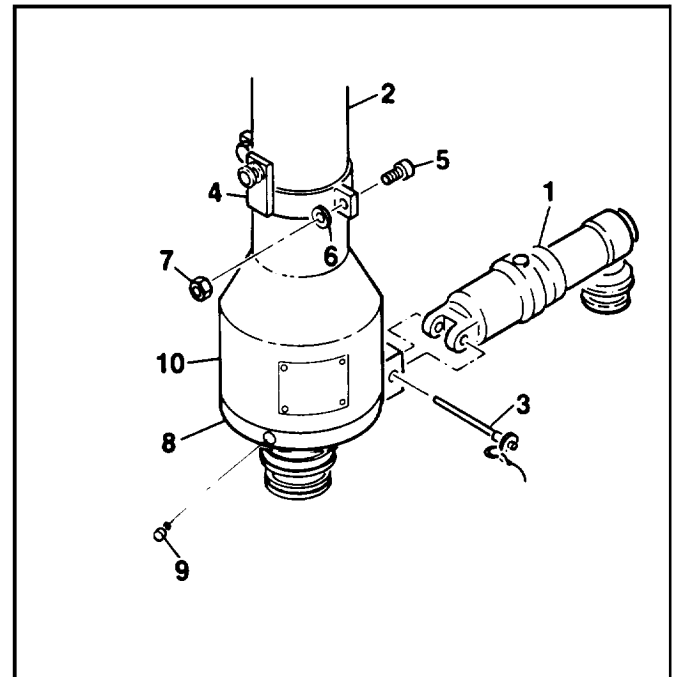
Tool Kit, Aircraft Mechanics
 NSN 5180-00-323-4692
 Shop Set, Intermediate Maintenance
 NSN 4920-00-472-4183
 Tool Kit, Electrical Repairer
 NSN 5180-00-323-4915

References:

None

1. Removal.

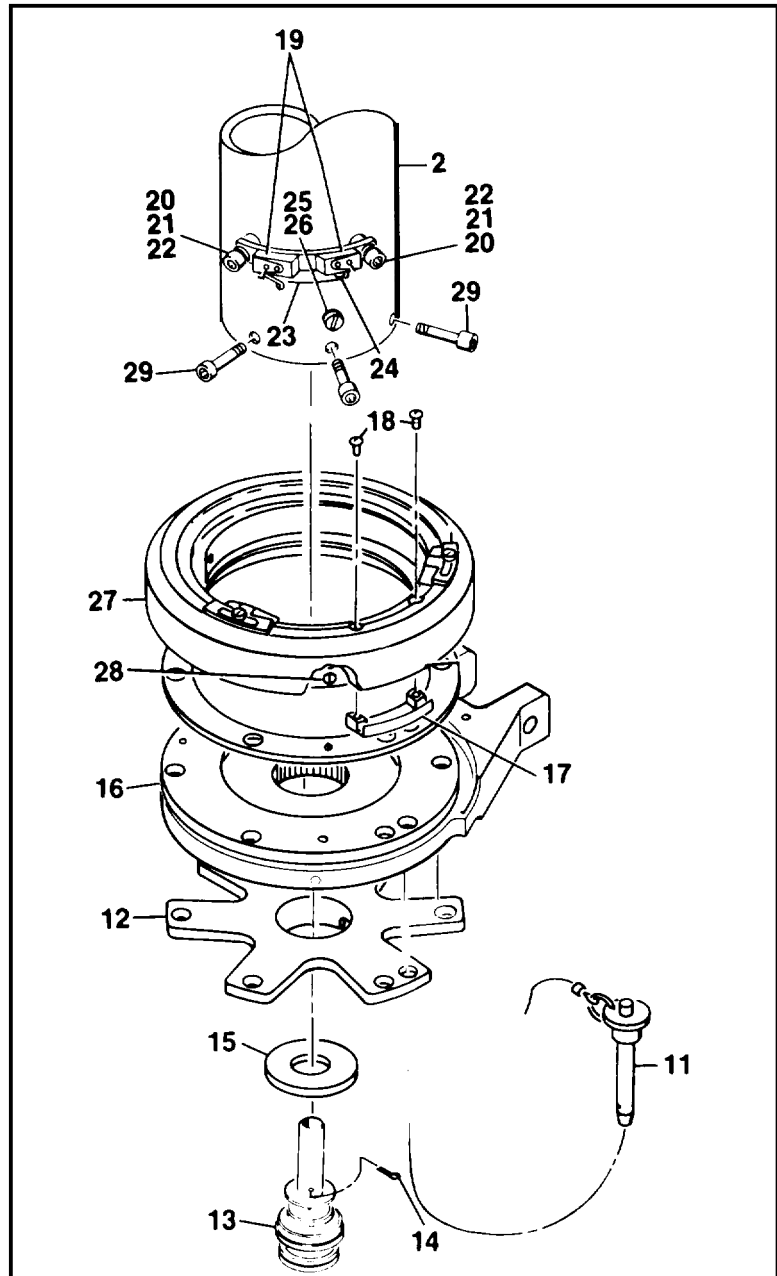
- a. Disconnect reaction arm assembly (1) from stanchion tube (2) by removing pin (3).
- b. Remove stud ring (4) from stanchion tube (2) by removing bolts (5), washers (6) and nuts (7).
- c. Remove ring (8) by removing screws (9). Slide switch cover (10) up stanchion tube (2).



GO TO NEXT PAGE

3-35. FLEXIBLE WIRING HARNESS - REPLACE (cont)

- d. Remove pins (11) from lower base plate (12).
- e. Remove quick disconnect (13) by removing cotter pin (14). Discard cotter pin. Remove washer (15) and lower base plate (12).
- f. Remove reaction plate assembly (16).
- g. Remove clamp (17) by removing screws (18). Disconnect limit switch electrical wiring from flexible wiring harness.
- h. Remove limit switches (19) by removing screws (20), washers (21) and spacers (22).
- i. Remove clamp (23) by removing screws (24). Disconnect electrical wiring from connector P4 and flexible wiring harness. Remove screw (25) and washer (26).
- h. Remove cam support (27) by removing screws (28). Remove bolts (29) and slide cam support off stanchion tube (2).



GO TO NEXT PAGE

3-35. FLEXIBLE WIRING HARNESS - REPLACE (cont)

3-35

- k. Remove flexible wiring harness (30) from cam support (27) by removing screw (31) and washer (32). Pull harness from support.

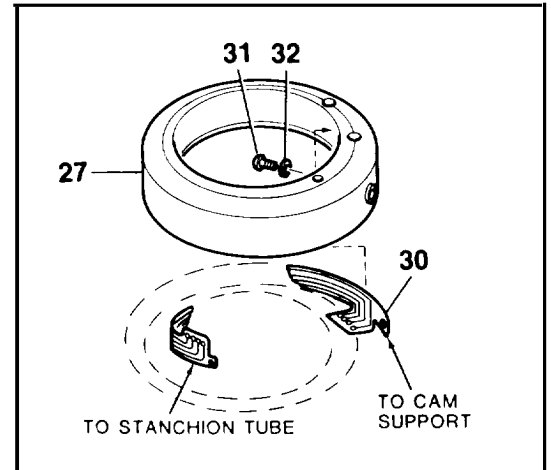
2. Installation.

- a. Position flexible wiring harness (30) into cam support (27).

NOTE

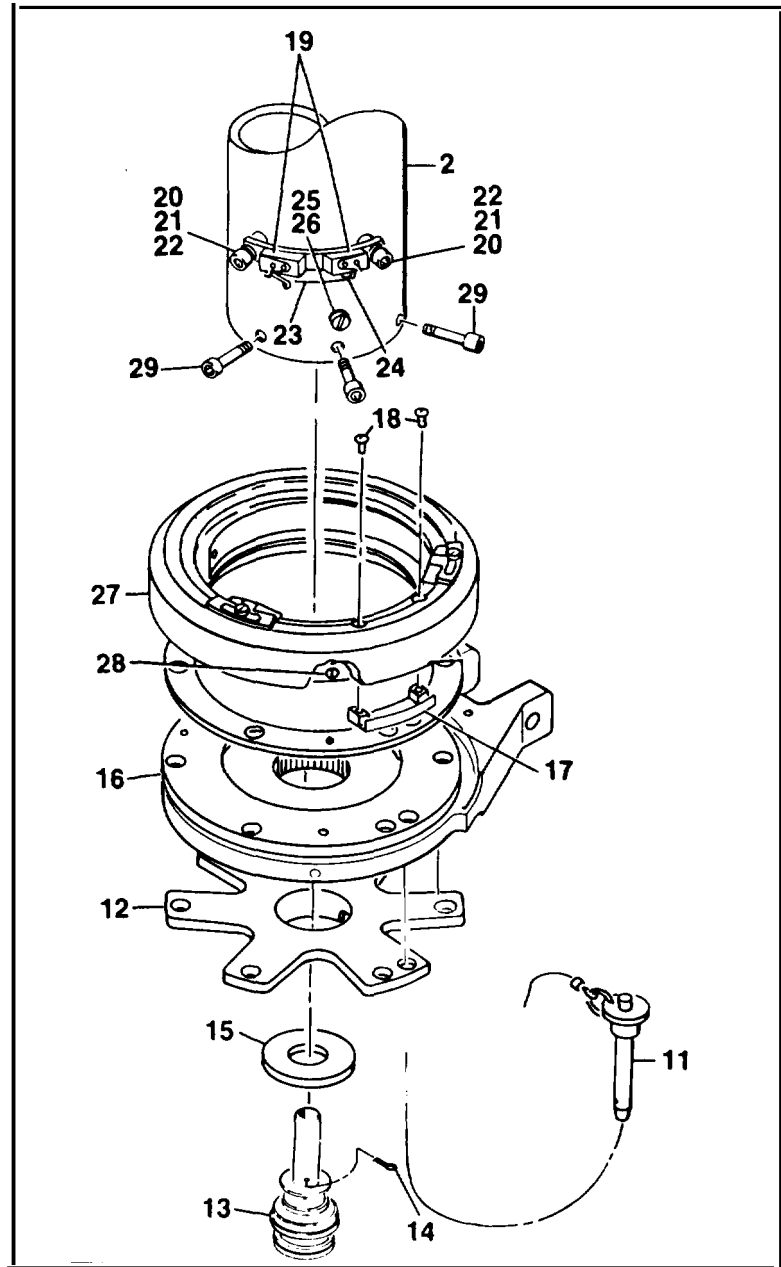
Wiring harness will spiral inside cam support for 2.5 revolutions. Ensure harness lays flat before securing.

- b. Secure one end of wiring harness (30) to cam support (27) using screw (31) and washer (32).

**GO TO NEXT PAGE**

3-35. FLEXIBLE WIRING HARNESS - REPLACE (cont)

- c. Slide cam support (27) onto stanchion tube (2). Install bolts (29).
- d. Connect electrical wiring from connector P4 and remaining end of flexible wiring harness (30) to stanchion tube (2) using screw (25) and washer (26).
- e. Install clamp (23) to stanchion tube (2) using screws (24).
- f. Install limit switches (19) using screws (20), washers (21) and spacers (22).
- g. Secure cam support (27) to stanchion tube (2) using screws (28).
- h. Install reaction plate assembly (16).
- i. Attach wiring harness (30) to limit switches. Install clamp (17) using screws (18).
- j. Install lower base plate (12), washer (15) and quick disconnect (13). Secure by installing cotter pins (14).
- k. Install pin (11) through lower base plate (12).



GO TO NEXT PAGE

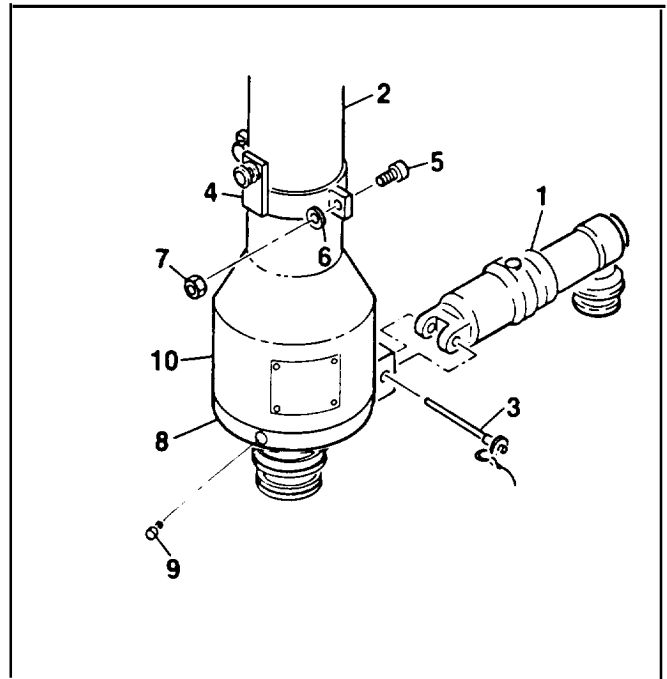
3-35. FLEXIBLE WIRING HARNESS - REPLACE (cont)

3-35

1. Install switch cover (10) and ring (8) and secure using screws (9).
- m. Install stud ring (4) onto stanchion tube (2) and secure using bolts (5), washers (6) and nuts (7).
- n. Attach reaction arm assembly (1) to stanchion tube (2) and secure using pin (3).

FOLLOW-ON MAINTENANCE:

None

**END OF TASK**

3-36. WINCH ASSEMBLY - REPAIR**3-36****This task covers: Disassembly, Cleaning, Inspection, Repair and Reassembly****INITIAL SETUP****Personnel Required:**

67N, UH1 Helicopter Repairer
 67T, UH60 Helicopter Repairer
 68F, Aircraft Electrical Repairer
 91W, Medevac Medics

Equipment Condition:

Hoist placed on suitable work bench
 Winch assembly removed

Parts/Materials:

Abrasive Cloth, Aluminum Oxide (Item 1, App. D)
 Cleaning Solvent (Item 10, App. D)
 Lockwire (Item 18, App. D)
 Loctite Compound (Item 16, App. D)
 Packing, NAS1593-133
 Packing (2), NAS1593-152
 Packing (2), 2-1 11V747-75
 Packing (2), M83248-1-011
 Petrolatum (Item 19, App. D)
 Screw, AN3H26A (Item 5, App. D)
 Trichloroethane (Item 25, App. D)

Equipment Condition Para:

Task 3-37

Tools and Test Equipment:

Tool Kit, Aircraft Mechanics
 NSN 5180-00-323-4692
 Shop Set, Intermediate Maintenance
 NSN 4920-00-472-4183
 Tool Kit, Electrical Repairer
 NSN 5180-00-323-4915
 Air Source, 35 psi

References:

Avionic Cleaning and Corrosion Prevention/Control
 TM 55-1500-343-23
 Aircraft Weapons Systems Cleaning and Corrosion Control
 TM 55-1500-344-23

GO TO NEXT PAGE

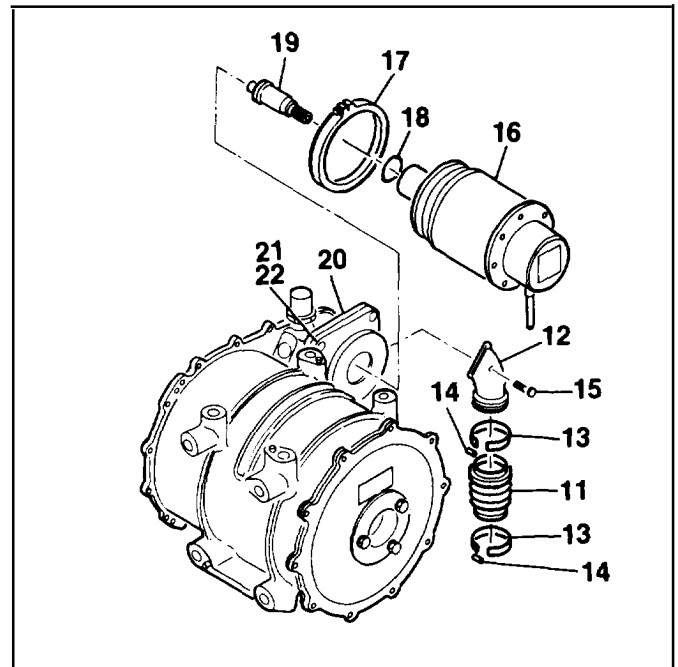
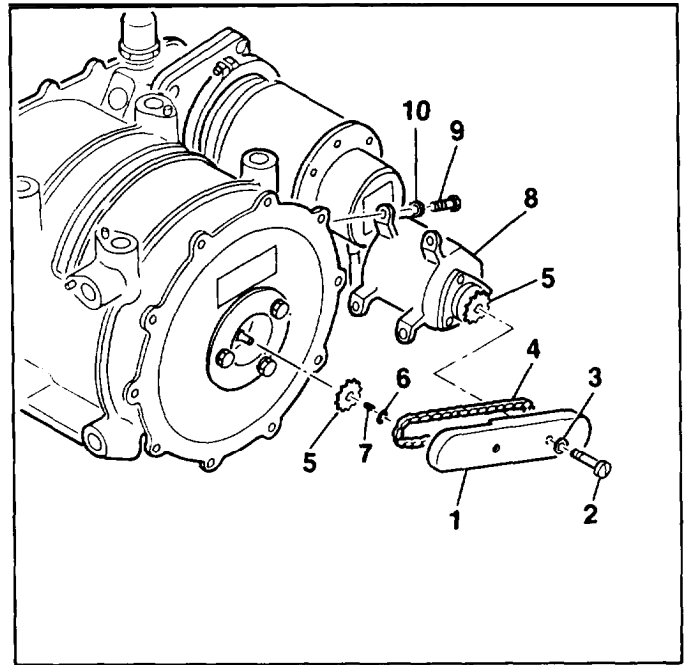
3-36. WINCH ASSEMBLY - REPAIR (cont)

3-36

1. Disassembly.**NOTE**

Prior to disconnecting chain (4) from switch drive assembly, mark sprocket on drive assembly and winch housing to preserve timing and prevent need for adjustment.

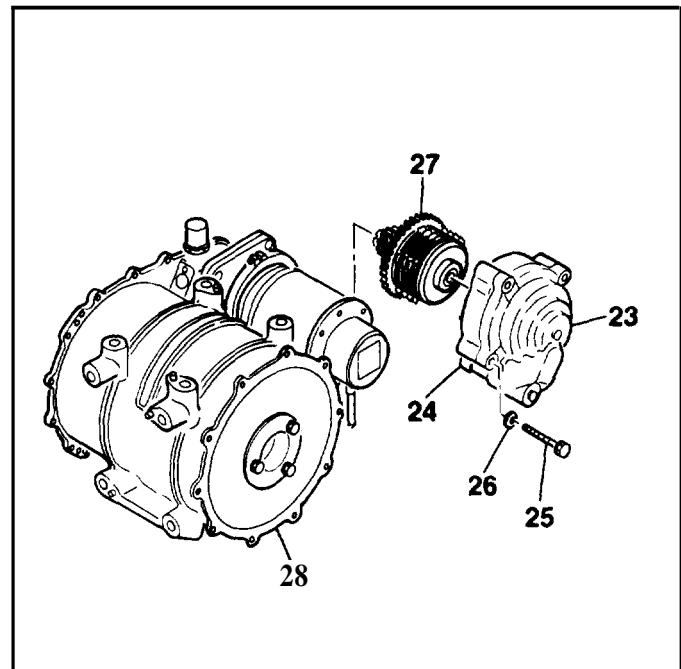
- a. Remove chain guard cover (1) by removing screws (2) and Washers (3).
- b. Remove chain (4) by removing master link.
- c. Remove sprocket (5) by removing retaining ring (6). Remove key (7).
- d. Remove lit switch drive assembly (8) by removing screws (9) and washers (10).
- e. Remove boot (11) from motor air duct (12) by removing bands (13) and clips (14). Remove airduct by removing bolts (15).
- f. Remove motor (16) by releasing coupling (17). Remove packing (18) from motor shaft and discard.
- g. Remove inertia dump assembly (19) from adapter plate (20).
- h. Remove adapter plate (20) by removing screws (21) and washers (22).

**GO TO NEXT PAGE**

NOTE

Brake may be difficult to remove from housing.

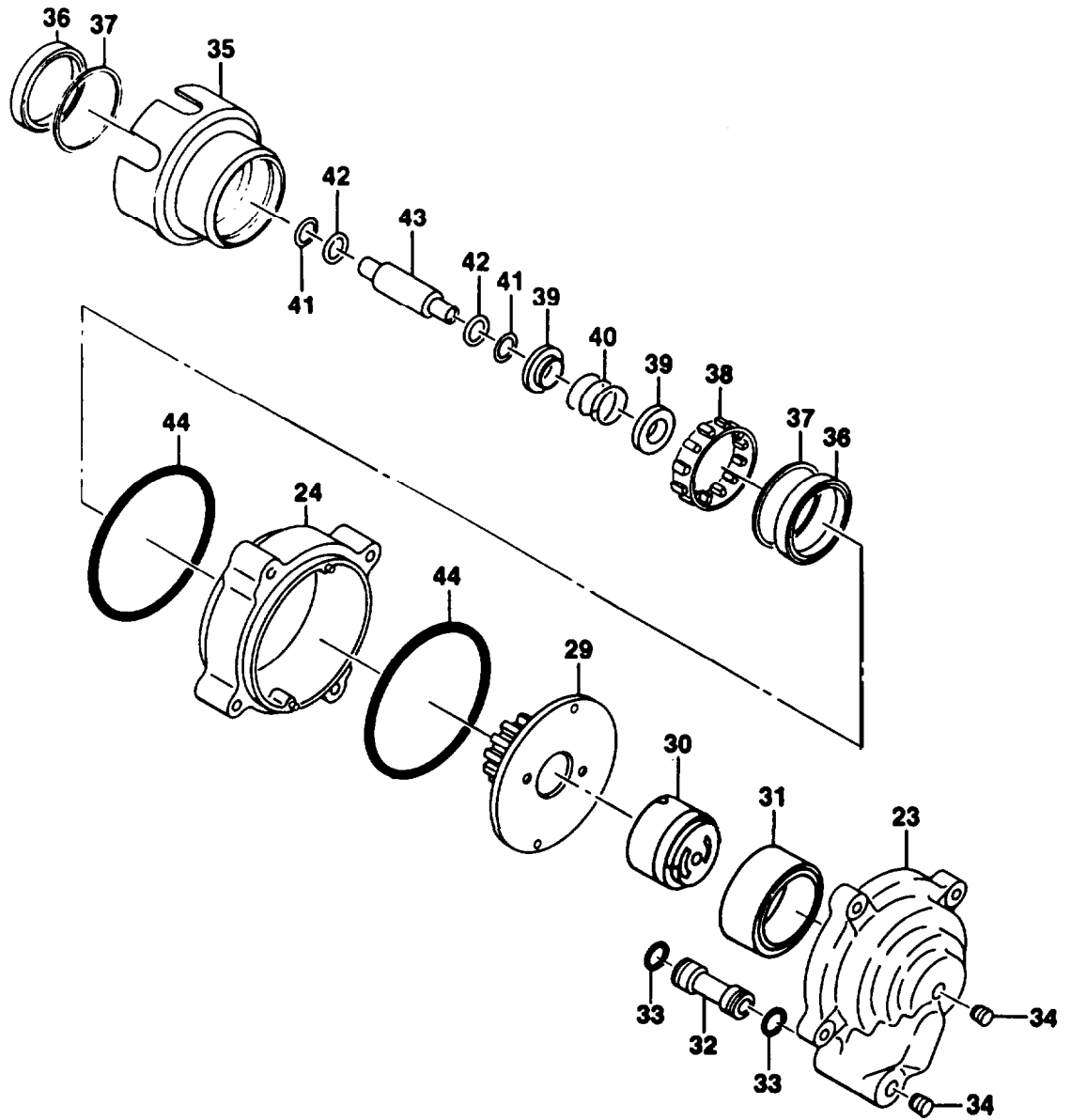
- i. Remove pump housing assembly (23) and brake housing (24) by removing bolts (25) and washers (26). Remove automatic brake assembly (27) from winch assembly (28).
- j. Separate pump housing (23) from brake housing (24). Remove shaft assembly (29), pump assembly (30) and bearing (31) from pump housing.
- k. Remove oil transfer tube (32) from pump housing (23). Remove and discard packings (33).
- l. Separate brake housing (24) from brake cup (35). Press out bearings (36) and remove spacers (37) from brake cup,
- m. Remove sprag clutch assembly (38), sleeve (39) and spring (40) from pump drive shaft (43), Remove retainers (41) and packings (42) from drive shaft. Discard packings.
- n. Remove packings (44) from brake housing (24) and discard,



GO TO NEXT PAGE

3-36. WINCH ASSEMBLY - REPAIR (cont)

3-36

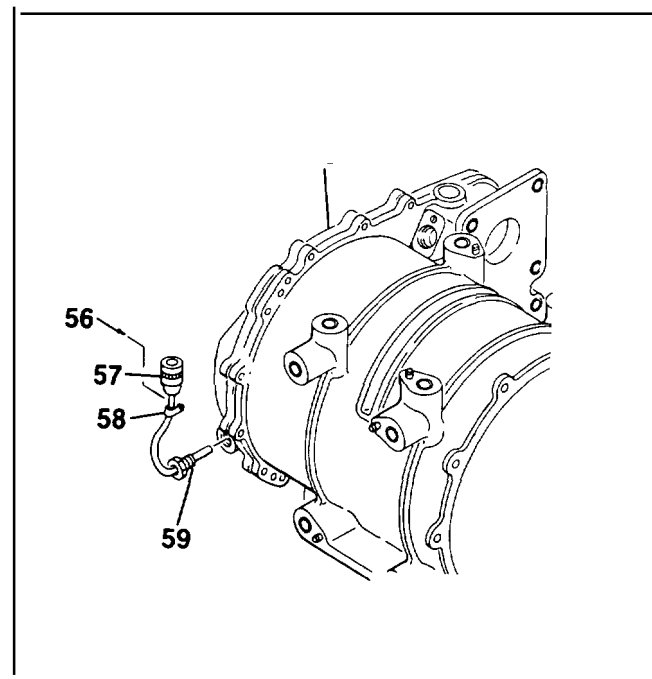
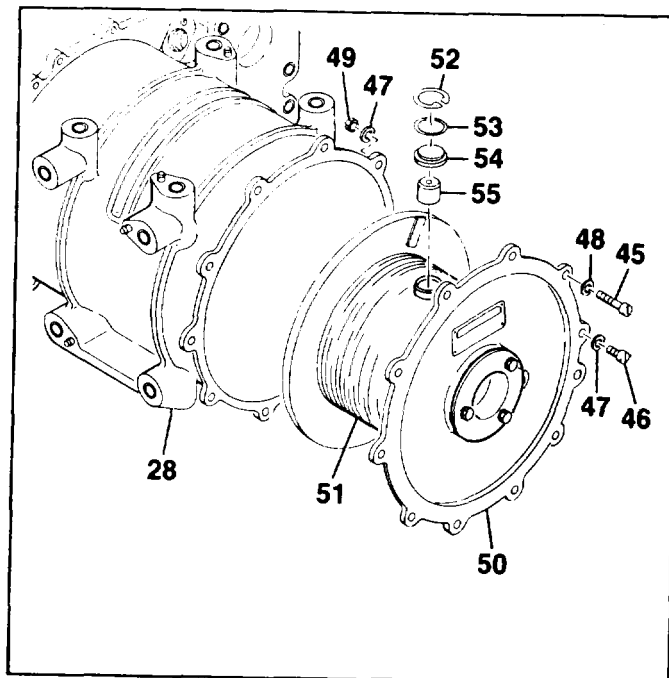


GO TO NEXT PAGE

3-36. **WINCH ASSEMBLY - REPAIR (cont)**

3-36

- o. Remove screws (45, 46), washers (47, 48) and nuts (49).
- p. Carefully remove assembled cover (50) and drum (51) from winch housing (28).
- q. Remove retaining ring (52) and shim (53). Remove retainer (54) and level wind shoe (55) from drum (51).
- r. Remove clamp (56) from connector (57) by removing screws (58).
- s. Using a suitable pin removal tool, remove pins from connector (57).
- t. Remove heat shrink tubing and electrical braid from thermal switch (59). Unscrew thermal switch from winch housing (28).



GO TO NEXT PAGE

3-36. WINCH ASSEMBLY - REPAIR (cont)

3-36**2. Cleaning.****WARNING**

Use solvent in a well ventilated area. Avoid prolonged breathing of fume. Keep away from open flame. Use approved safety equipment.

WARNING

Use approved personal protective equipment (goggles/face shield) when using compressed air. Air pressure is restricted to a maximum of 35 psi. Do not direct airstream towards self or other personnel.

CAUTION

Do not immerse electrical components in cleaning solvent. Wipe clean with a cloth dampened in soap and water solution.

CAUTION

If parts are not to be inspected immediately after cleaning, dip them in preservation oil to prevent rust spots.

- a. Clean electrical connector contact pins with cloth soaked in trichloroethane in accordance with TM 55-1500-343-23.
- b. Wash remaining components in solvent and rinse thoroughly. Dry with compressed air.
- c. Clean drum assembly grooves with solvent and rinse thoroughly. Dry with compressed air.

3. Inspection.

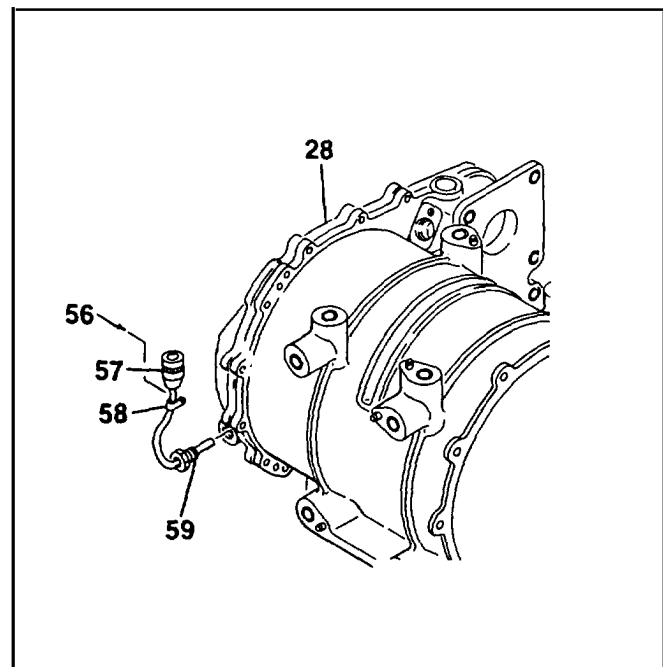
- a. Inspect all parts for nicks, cracks, scratches and dents (refer to Task 2-11).
- b. Inspect for corrosion (refer to Task 2-11) and evidence of leakage.
- c. Inspect all threaded parts for crossed, stripped and damaged threads.
- d. Inspect electrical wiring for frayed and broken insulation. Check for cuts and tears.
- e. Inspect electrical connectors for bent, broken and missing pins. Inspect for evidence of overheating and shorting.
- f. Inspect drum and cover assembly for smooth rotation of drum.
- g. Inspect cable kicker for loose rivets.
- h. Inspect drum grooves for nicks, dings and cracks.

GO TO NEXT PAGE

- i. Inspect identification and lubrication plates for legibility and security of attachment.
 - j. Inspect limit switch drive assembly and motor assembly for damage. Check for signs of overheating and shorting.
 - k. Inspect boot and motor air duct for cuts and deterioration.
 - l. Inspect cable hook in accordance with Task 2-56.
 - m. Inspect hoist cable in accordance with Task 2-59.
4. **Repair.** Repair of parts is limited to the removal of minor nicks, burrs, scratches or other surface damage using aluminum oxide cloth or fine abrasive. Clean pans thoroughly after repair. If damage is extensive, or if minor repair will affect serviceability, replace the part.

5. **Reassembly.**

- a. Screw thermal switch (59) into winch housing (28). Install electric braid and heat shrink tubing on leads of switch.
- b. Using a suitable pin installation tool, install pins into connector (57). Twist ends of electric braid to secure and shrink heat shrink tubing in place.
- c. Install clamp (56) onto connector (57) using screws (58).

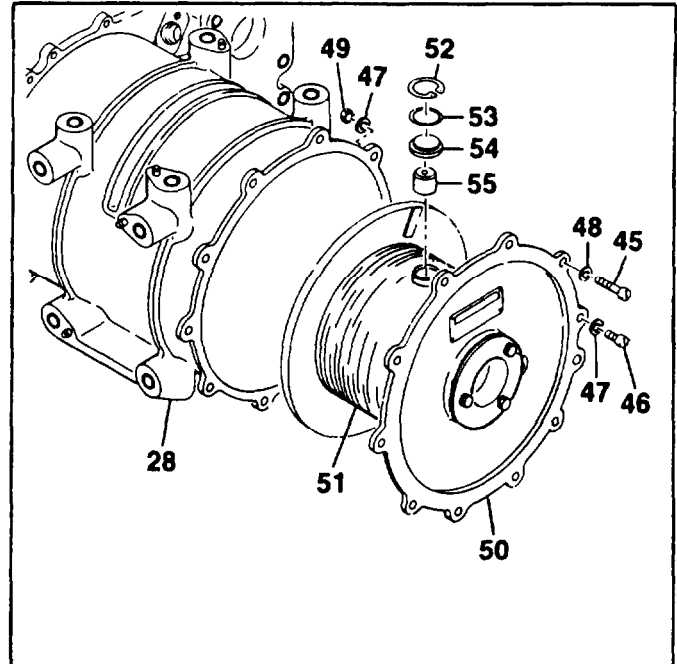


GO TO NEXT PAGE

3-36. WINCH ASSEMBLY - REPAIR (cont)

3-36

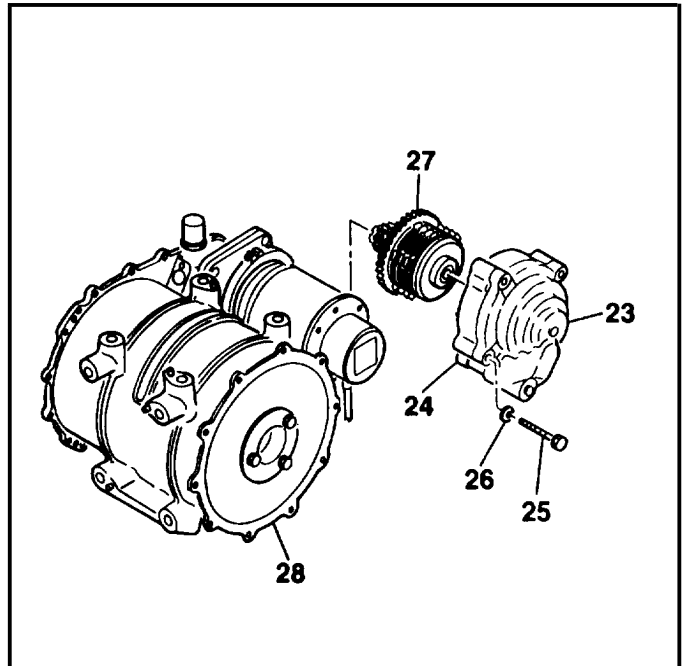
- d Using a 10-32 screw, install level wind shoe (55) and retainer (54).
- e. Install shims (53), as required, to obtain an end play of **0.004-0.008 in. (0.010-0.020 cm)** between shoe (55) and retainer (54). Install retaining ring (52) into drum assembly. Align matched curved surfaces.
- f. Position drum assembly (51) near flush with drum cover assembly (50) by rotating drum in relation to cover.
- g. Lower assembled drum (51) and cover (50) into winch housing (28). Ensure proper alignment of drum shaft and drum drive gear splines.
- h. Align cover (50) to housing (28) to enable installation of limit switch drive assembly (10). Install screws (45, 46), washers (47, 48) and nuts (49), Torque screws to **12-15 in-lbs.**



GO TO NEXT PAGE

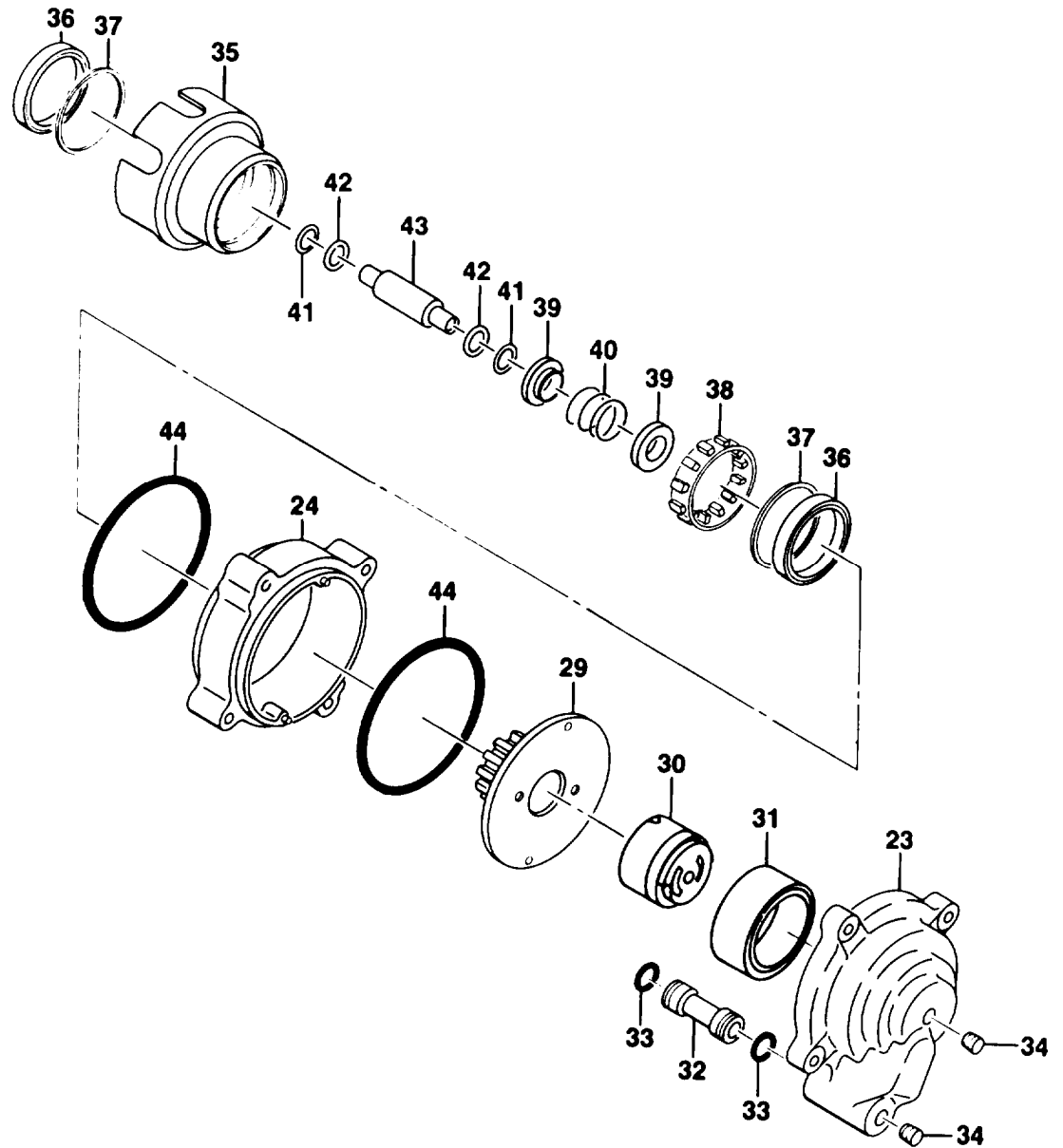
3-36. WINCH ASSEMBLY - REPAIR cont)

- i. Lubricate packings (44) and install onto brake housing (24).
- j. Lubricate packings (42) and install onto pump drive shaft (43). Install sprag clutch assembly (38), sleeve (39), spring (40) and retainers (41) onto drive shaft.
- k. Install bearings (36) and spacers (37) into brake cup (35). Mate brake housing (24) to brake cup.
- l. Lubricate packings (33) and install onto oil transfer tube (32). Install oil transfer tube into pump housing (23).
- m. Install shaft assembly (29), pump assembly (30) and bearing (31) into pump housing (23). Mate pump housing to brake housing (24).
- n. Fit automatic brake assembly (27) into winch assembly (28).
- o. Install brake housing (24) and pump housing (23) onto winch assembly (28). Secure using bolts (25) and washers (26).



GO TO NEXT PAGE

3-36. WINCH ASSEMBLY - REPAIR (cont)



GO TO NEXT PAGE

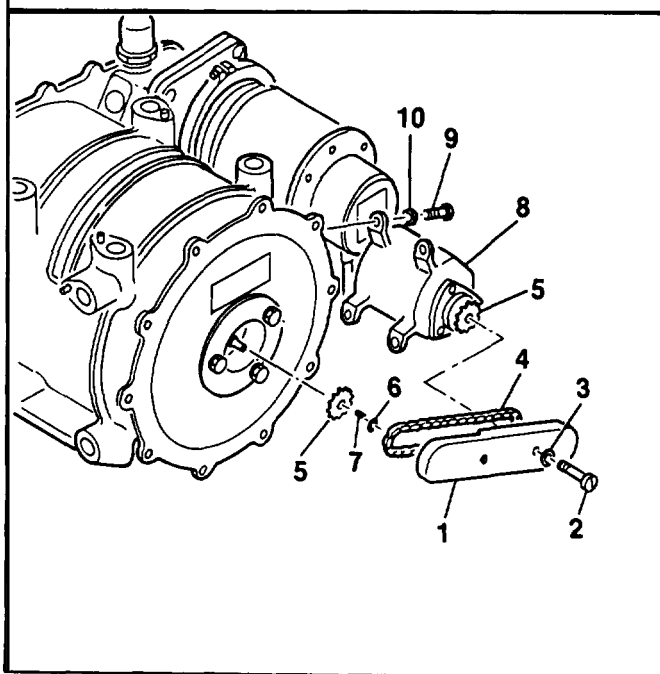
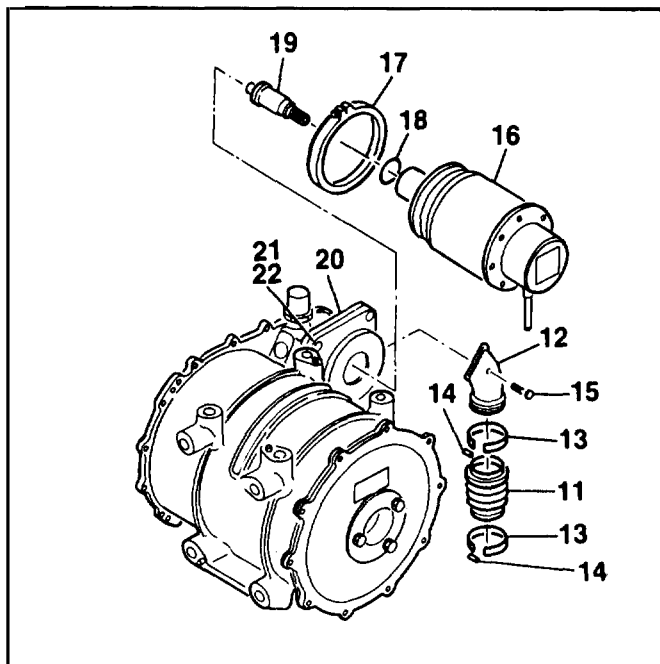
3-36. WINCH ASSEMBLY - REPAIR (cont)

- p. Install adapter (20) and secure using screws (21) and washers (22).
- q. Install coupling (17) onto adapter plate (20).
- r. Lubricate packings (18) and install on shaft of motor (16). Align inertia dump assembly (19) and install.
- s. Align pin on adapter plate with hole on motor end bell. Install motor (16) onto adapter plate (20), ensuring splined end of motor meshes with inertia dump assembly (19). Secure by tightening coupling (17),
- t. Install airduct (12) using screws (15). Install boot (11) using bands (13) and clips (14),
- u. Install limit switch drive assembly (8) using screws (9) and washers (10). **Torque screws to 12-15 in-lbs.**
- v. Install key (7). Install sprocket (5) and secure using retaining ring (6).

NOTE

Limit switch drive screws (11 may be loosened to assist in the installation Of roller chain (4). Tighten screws after installation.

- w. Position unconnected roller chain (4) onto sprocket (5) and limit switch drive assembly (10). Connect chain by installing master link.
- x. Apply loctite compound to threads of screws (2). Install chain guard cover (1) using screws and washers (3). Torque screws to 12-15 in-lbs.



FOLLOW-ON MAINTENANCE:

Install winch assembly
(Task 3-37)

END OF TASK

3-37. WINCH ASSY - REPLACE**3-37****This task covers: Removal and Installation****INITIAL SETUP****Personnel Required:**

67N, UH1 Helicopter Repairer
 67T, UH60 Helicopter Repairer
 91W, Medevac Medics

Equipment Condition:

Hoist placed on suitable work bench
 Boom head assembly removed
 Hoist cable removed
 Winch assembly drained

Part/Materials:

None

Equipment Condition Para:

Task 2-20
 Task 2-60
 Task 2-45

Tools and Test Equipment:

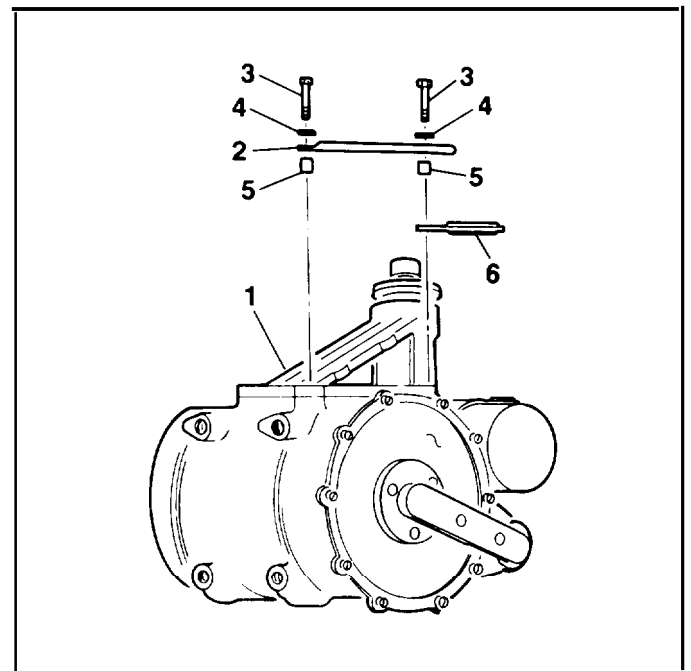
Tool Kit, Aircraft Mechanics
 NSN 5180-00-323-4692
 Shop Set, Intermediate Maintenance
 NSN 4920-00-472-4183

References:

None

1. Removal.

- a. Remove upper support assembly (1) and carrying handle (2) by removing bolt (3), washers (4) and spacers (5). Remove bracket (6).

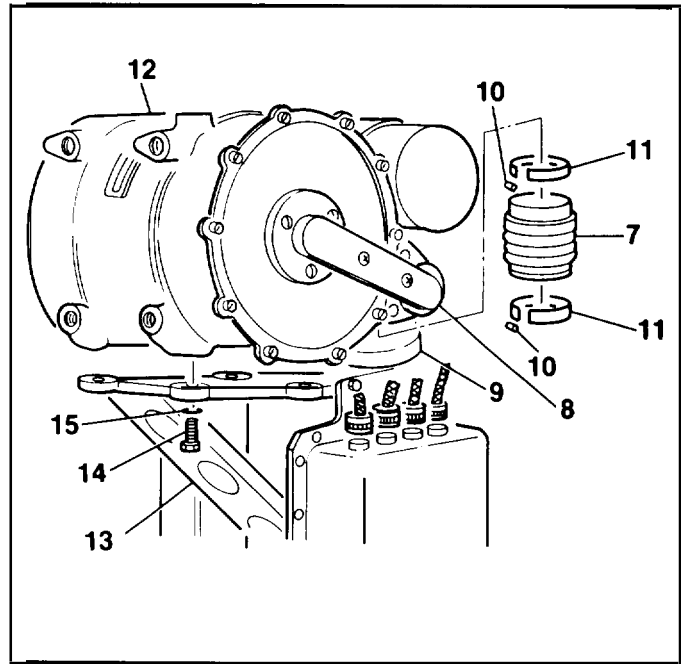
**GO TO NEXT PAGE**

3-37. WINCH ASSY - REPLACE (cont)

- b. Remove boot (7) from motor air duct (8) and control panel fan plenum (9) by removing clips (10) and bands (11).
- c. Remove winch assembly (12) from support assembly (13) by removing bolts (14) and washers (15).

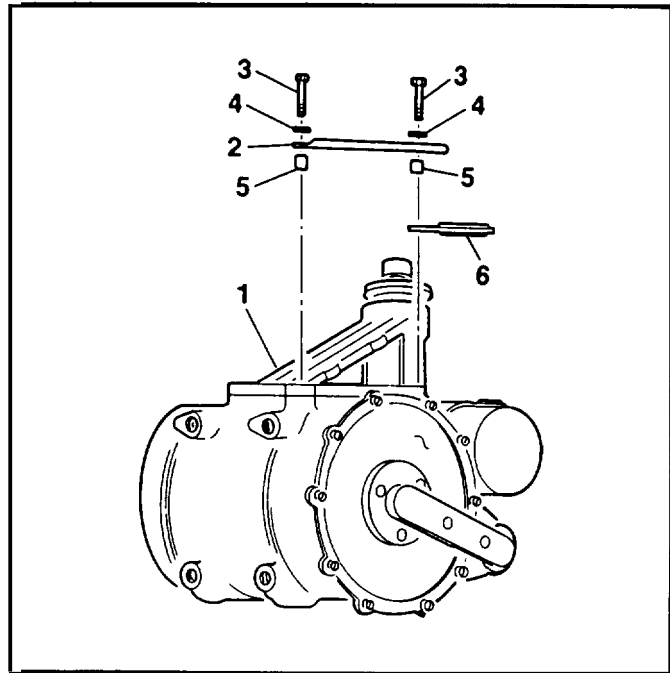
2. Installation.

- a. Install winch assembly (12) onto support assembly (13) and secure using bolts (14) and washers (15). **Torque bolts to 160-190 in-lbs.**
- b. Install boot (7) between motor air duct (8) and control panel fan plenum (9) and secure using bands (11) and clips (10).
- c. Install upper support assembly (1), carrying handle (2) and bracket (6) onto winch assembly (12) and secure using bolts (3), washers (4) and spacers (5). **Torque bolts to 160-190 in-lbs.**



FOLLOW-ON MAINTENANCE:

- Install boom head assembly (Task 2-20)
- Install hoist cable (Task 2-60)
- Service winch assembly (Task 2-45)
- Adjust limit switch drive assembly (Task 2-54)
- conduct performance check (Task 3-7)



END OF TASK

3-38. LIMIT SWITCH DRIVE ASSY - REPAIR**3-38**

This task cover : Disassembly, Cleaning, Inspection, Repair and Reassembly

INITIAL SETUP**Personnel Required:**

67N, UH1 Helicopter Repairer
 67T, UH60 Helicopter Repairer
 68F, Aircraft Electrical Repairer
 91W, Medevac Medics

Parts/Materials:

Cleaning Solvent (Item 10, App.D)
 Grease (Item 12, App.D)
 Packing, M83248-1-035
 Shim, 49001C6
 Shim, 49001C10

Tools and Test Equipment:

Tool Kit, Aircraft Mechanics
 NSN 5180-00-323-4692
 Shop Set, Intermediate Maintenance
 NSN 4920-00-472-4183
 Tool Kit, Electrical Repairer
 NSN 5180-00-323-4915
 Multimeter
 Air Source, 35 psi

Equipment Condition:

Hoist installed in assembly stand
 Limit drive assembly removed

Equipment Condition Para:

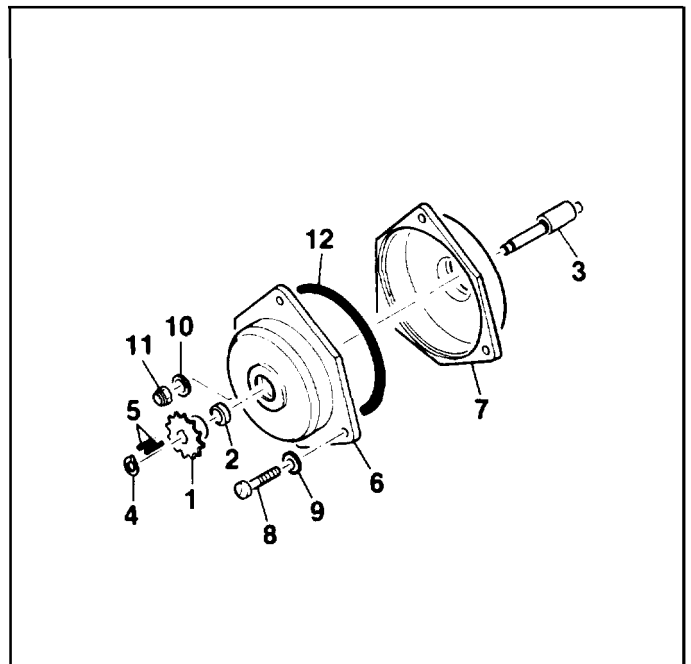
Task 3-5
 Task 2-55

References:

Avionic Cleaning and Corrosion Prevention/Control
 TM 55-1500-343-23
 Aircraft Weapons Systems Cleaning and Corrosion Control
 TM 55-1500-344-23
 Aircraft Electric and Electronic Wiring
 TM 55-1500-323-24

1. Disassembly.

- a. Remove sprocket gear (1) and spacer (2) from shaft (3) by removing retaining ring (4). Remove keys (5).
- b. Remove gear (6) and retainer (7) by removing screws (8), washers (9, 10) and nut (11).
- c. Separate gear (6) from retainer (7). Remove and discard packing (12).



GO TO NEXT PAGE

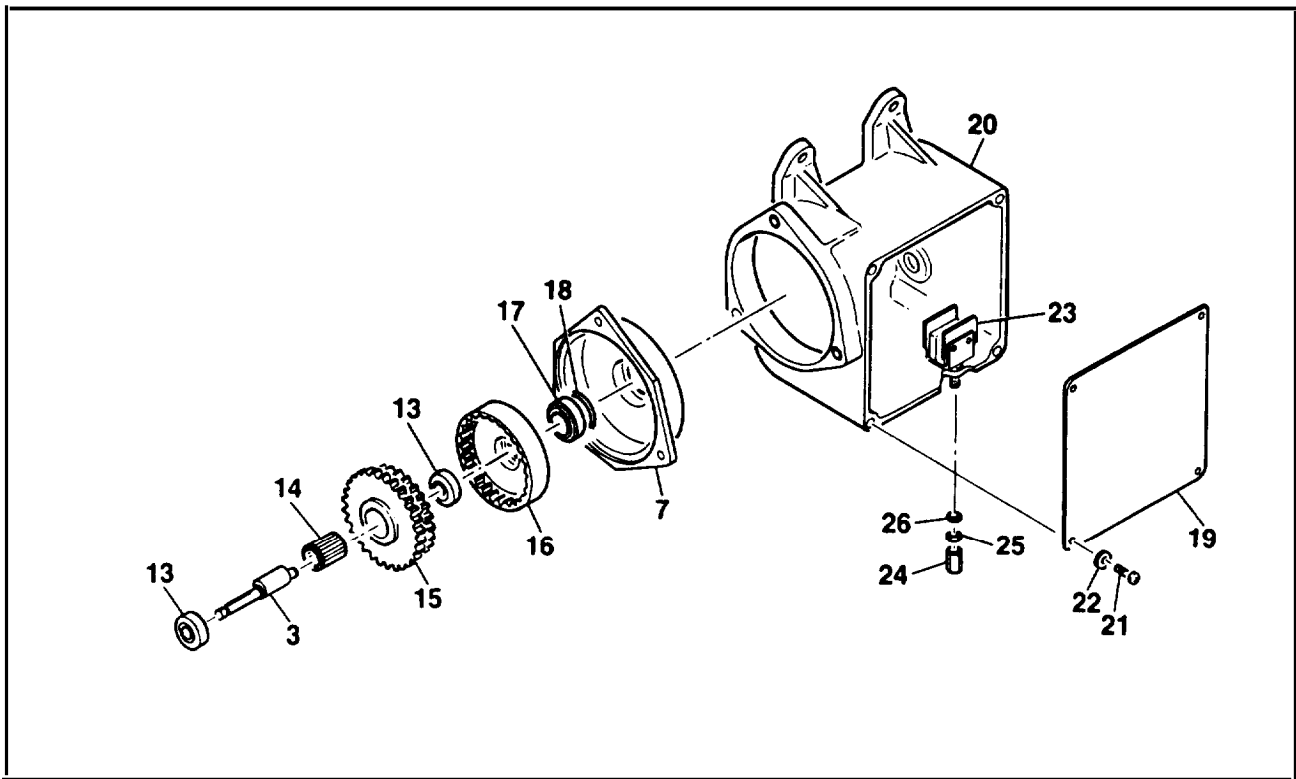
3-38. LIMIT SWITCH DRIVE ASSY - REPAIR (cont)**3-38**

- d. Remove front bearing (13) from shaft (3).
- e. Remove shaft (3) and bearing (14) from bore of cluster gear (15) and gear (16). Remove rear bearing (13).

NOTE

Note and record number of shims (18) removed to aid in reassembly.

- f. Remove bearing (17) from gear (16). Remove shims (18) from retainer (7).
- g. Remove cover (19) from housing (20) by removing screws (21) and washers (22).
- h. Disconnect electrical wiring and remove switch (23) by removing cap (24), washer (26) and nut (25).

**GO TO NEXT PAGE**

3-38. LIMIT SWITCH DRIVE ASSY - REPAIR (cont)**3-38****NOTE**

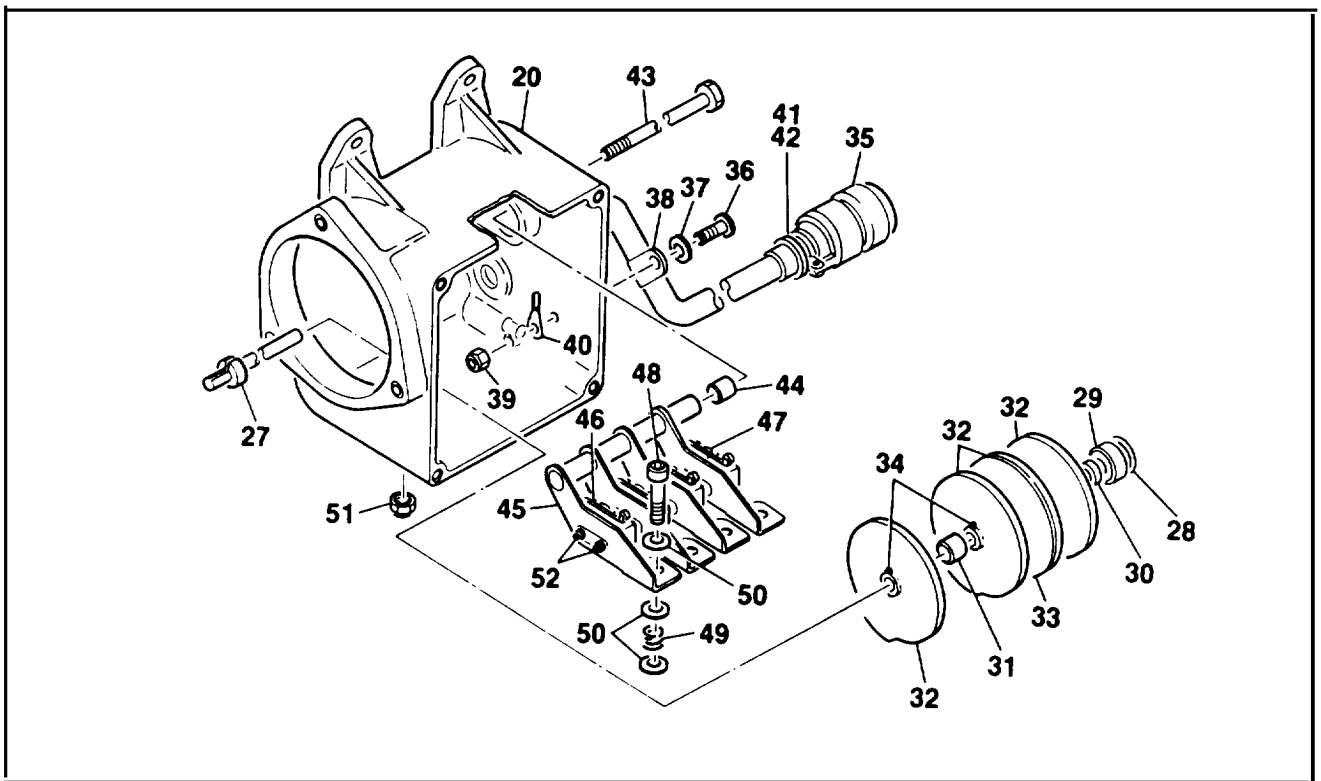
Note and record number of shims (28) removed to aid in reassembly.

- i. Disassemble cam assembly by removing cam shaft (27), shims (28), bearing (29) and spacers (30, 31). Remove cams (32, 33) by loosening cam adjustment screws (34).
- j. Remove plug (35) from housing (20) by removing screw (36), washer (37), clamp (38), and nut (39). Remove terminal lug (40).
- k. Disassemble plug (35) by removing screws (41) and clamp (42). Using a suitable pin removal tool, remove pins from connector. Remove heat shrink tubing and electric braid from switch leads.
- l. Remove shaft (43) and spacers (44) from bracket (45).

NOTE

Removal of brackets (45) will alter limit switch (46, 47) actuation setting. Do not remove brackets unless required.

- m. Remove brackets (45) by removing screws (48), springs (49), washers (50) and nuts (51).
- n. Remove limit switches (46, 47) by removing screws (52).



GO TO NEXT PAGE

2. Cleaning.**WARNING**

Use cleaning solvent in a well-ventilated area. Avoid prolonged breathing of fumes. Keep away from open flame, Use approved safety equipment.

WARNING

Use approved personal protective equipment (goggles/face shield) when using compressed air. Air pressure is restricted to a maximum of 35 psi. Do not direct airteam towards self or other personnel.

CAUTION

Do not immerse electrical components in cleaning solvent. Wipe clean with a cloth dampened in soap and water solution.

CAUTION

If parts are not to be inspected immediately after cleaning, dip them in preservation oil to prevent rust spots

- a. Clean electrical connector pins in accordance with procedures outlined in TM 55-1500-343-23.
- b. Clean electrical components by wiping clean with cloth dampened in trichloroethane. Wipe with a clean, dry cloth and allow to air dry.
- c. Ensure all old grease is removed from bearings. Lubricate with with grease at reassembly.
- d. Wash remaining components in solvent and rinse thoroughly. Dry with compressed air

GO TO NEXT PAGE

3-38. LIMIT SWITCH DRIVE ASSY - REPAIR (cont)

3-38**3. Inspection.**

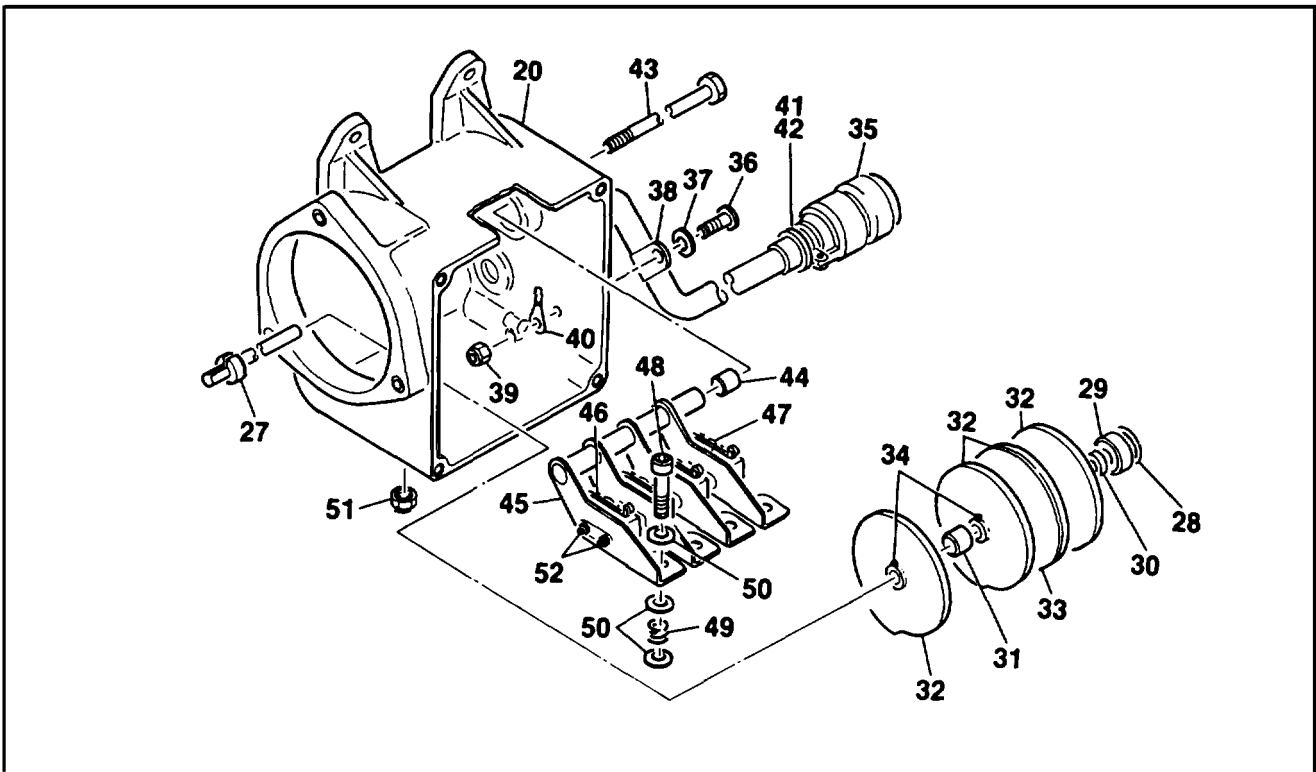
- a. Inspect for nicks, cracks, scratches and dents (refer to Task 2-11).
- b. Inspect for corrosion (refer to Task 2-11).
- c. Inspect electrical wiring for frayed and broken insulation. Check for cuts and tears.
- d. Inspect electrical connector for bent, broken and missing pins.
- e. Inspect for evidence of overheating and shorting.
- f. Inspect gears for nicks, burrs, galling, pitting and uneven wear. Check for chipped or cracked teeth.
- g. Inspect identification plates for legibility and security of attachment.

4. **Repair.** Repair of parts is limited to removal of minor nicks, burrs, scratches or other surface damage using aluminum oxide cloth or fine abrasive. Clean part thoroughly after repair. If damage is extensive, or if minor repair will affect serviceability, replace the part.

GO TO NEXT PAGE

5. Reassembly.

- a. Secure limit switches (46, 47) to brackets (45) using screws (52).
- b. Install brackets (45) into position in housing (20). Insert shaft (43) through housing, one spacer (44), brackets (45), second spacer (44) and out opposite side of housing.
- c. Secure brackets (45) to housing (20) using screws (48), springs (49), washers (50) and nuts (51). Limit switch adjustment will be achieved after limit switch drive assembly is assembled.
- d. Feed limit switch electrical wiring through grommets hole in housing (20). Install electric braid and twist to secure. Install heat shrink tubing and shrink in place.
- e. Using a suitable pin installation tool, install pins into connector (35). Install clamp (41) and secure using screws (42).
- f. Insert electrical wiring from limit switches (46, 47) into clamp (38). Secure clamp to housing (20) using screw (36), washer (37) and nut (39).
- g. Insert shims (28) into housing (20).
- h. Lubricate bearing (29) with grease. Assemble bearing, spacers (30, 31) and cam assemblies (32, 33) onto shaft (27). Install assembly into housing (20). Secure cam assemblies by tightening cam screws (34).

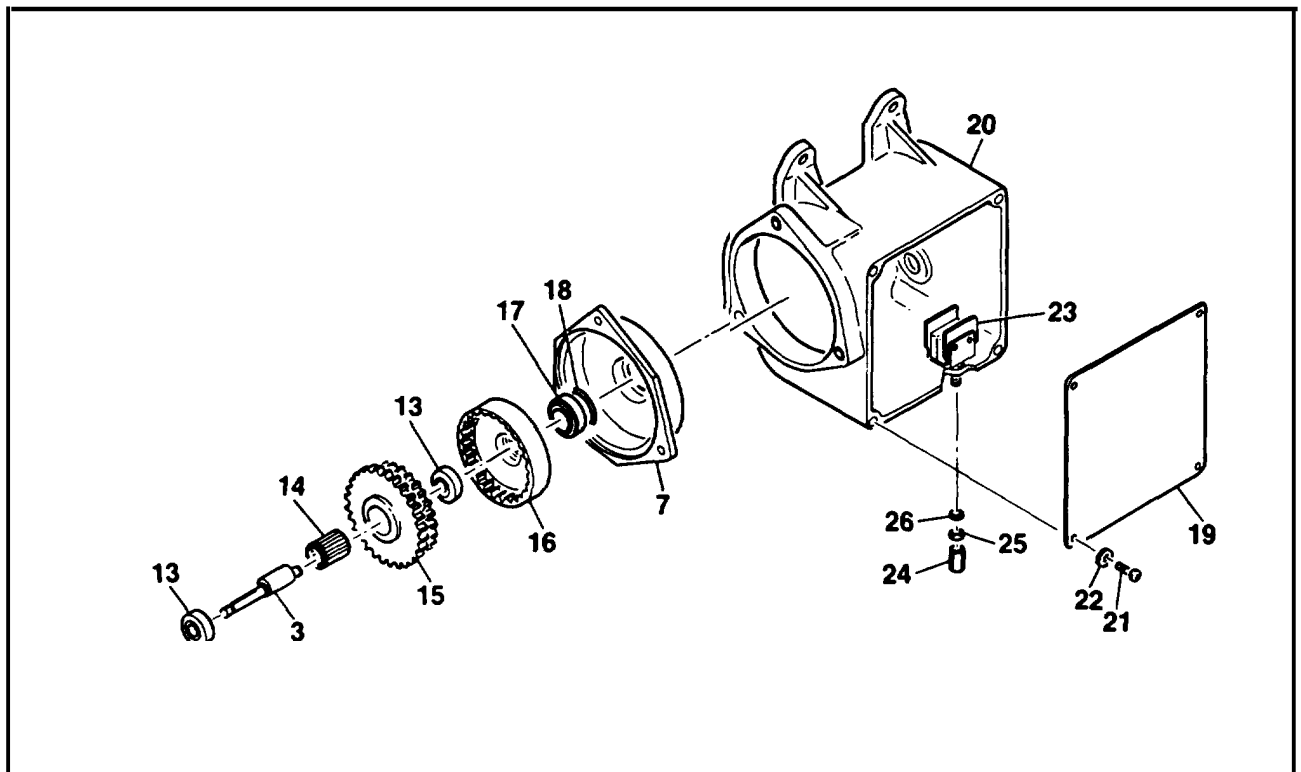


GO TO NEXT PAGE

3-38. LIMIT SWITCH DRIVE ASSY - REPAIR (cont)

3-38

- i. Connect electrical wiring to switch (23) and install switch into housing (20). Secure using washer (26), nut (25) and cap (24).
- j. Install shims (18) into retainer (8).
- k. Lubricate bearing (17) with grease and install onto gear (16). Lubricate bearing (14) with grease and install into cluster gear (15).
- l. Install shaft (3) into bearing (14). Lubricate bearings (13) with grease and install onto shaft.
- m. Lightly lubricate cluster gear (15) and gear (16) with grease. Fit gears together on shaft (3).
- n. Install shaft (3) and assembled gears into retainer (8). Adjust number of shims (18) installed in step j. to achieve a shaft end play of **0.004-0.008 in. (0.010-0.020 cm)**.
- o. Install cover (19), after completion of adjustment procedures, using secure using screws (21) and washers (22).



GO TO NEXT PAGE

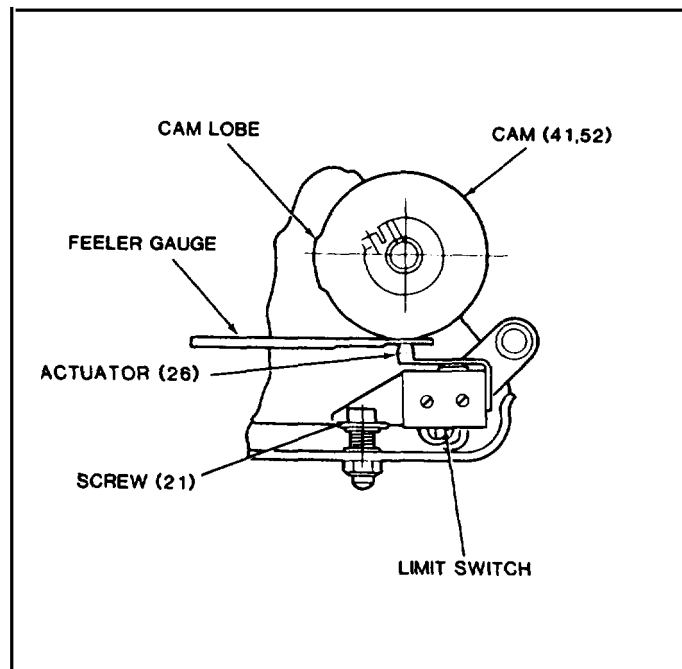
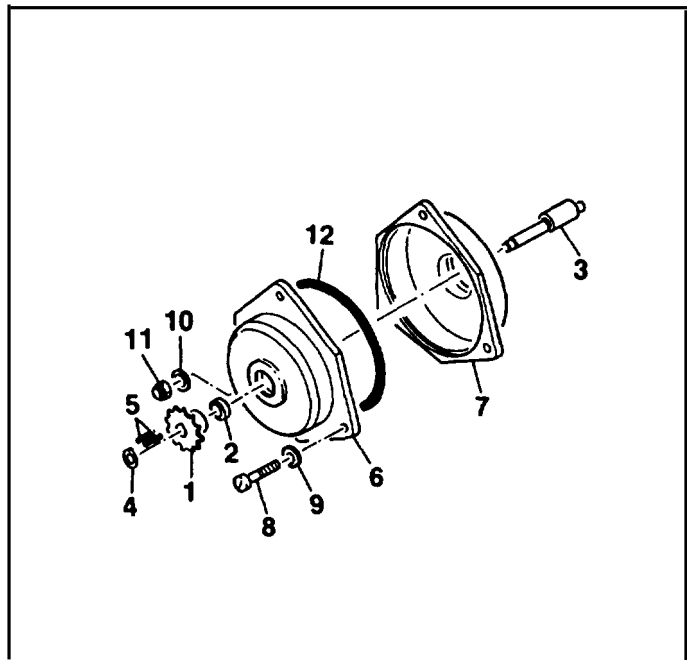
3-38. LIMIT SWITCH DRIVE ASSY - REPAIR (cont)

- p. Lubricate packing (12) and install into retainer (7). Mate retainer with gear (6).
- q. Install gear (6) and retainer (7) onto housing (20) and secure using screws (8), washers (9, 10) and nut (11).
- r. **End play of shaft (27) shall be 0.004-0.008 in. (0.010-0.020 cm).** Adjust numbers of shims (28) installed in step g. to achieve end play,
- s. Install sprocket (1) and spacer (2) onto shaft (3). Insert keys (5) and secure sprocket (1) using retainer (4).
- t. Adjust limit switch actuation setting as follows:

NOTE

Ensure switch (23) is not actuated during this adjustment.

- (1) Rotate cams (32, 33) so that limit switch actuators rest on minimum diameter surface of cams (away from cam lobe).
- (2) Connect ohmmeter to pins A and B on drive assembly electrical connector. Slide 0.045 in. (0.114 cm) feeler gauge between limit switch S1 actuator and cam (32).
- (3) Adjust bracket screw (48) until switch circuit just closes (limit switch on). Remove 0,045 (0.114 cm) feeler gauge.
- (4) Slide 0.020 (0.050 cm) feeler gauge between limit switch S 1 actuator and cam (32). Switch circuit shall be open (limit switch off).



GO TO NEXT PAGE

3-38. LIMIT SWITCH DRIVE ASSY - REPAIR (cont)

3-38

- (5) Repeat steps (2), (3) and (4) for limit switch S2, using pins C and D.
- (6) Repeat steps (2), (3) and (4) for limit switch S3, using pins E and F.
- (7) Repeat steps (2), (3) and (4) for limit switch S4, using pins G and H.

FOLLOW-ON MAINTENANCE:

Test limit switch drive assembly
(Task 3-39)

END OF TASK

This task covers: Testing

INITIAL SETUP

Personnel Required:

67N, UH1 Helicopter Repairer
 67T, UH60 Helicopter Repairer
 68F, Aircraft Electrical Repairer
 91W, Medevac Medics

Equipment Condition:

Hoist in assembly stand
 Limit switch drive assembly removed

Parts/Material:

None

Equipment Condition Para:

Task 3-5
 Task 2-55

Tools and Test Equipment:

Tool Kit, Aircraft Mechanics
 NSN 5180-00323-4692
 Shop Set, Intermediate Maintenance
 NSN 4920-00-472-4183
 Multimeter

Reference

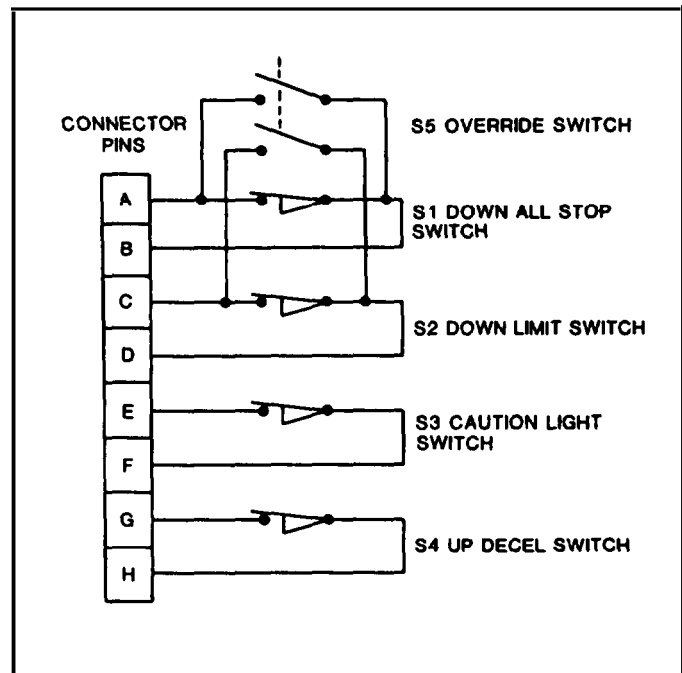
None

1. Remove instruction plate by removing screws and washers.

NOTE

Ensure cam lobes are not engaging limit switch actuators during testing. Limit switches are normally closed.

2. Connect multimeter to pins A and B of drive assembly electrical connector. There shall be continuity.
3. Press down on limit switch S1 actuator. Continuity shall not be present. Release actuator.
4. Depress override switch. If continuity is not present, replace override switch (Task 3-38).



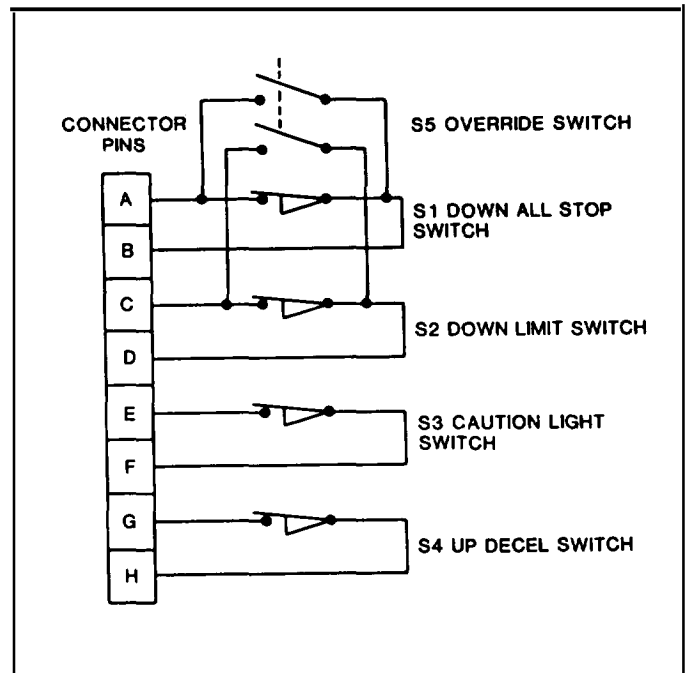
GO TO NEXT PAGE

3-39. LIMIT SWITCH DRIVE ASST - TEST (cont)**3-39**

5. Connect multimeter to pins C and D. There shall be continuity.
6. Press down on limit switch S2 actuator. Continuity shall not be present. Release actuator.
7. Depress override switch. If continuity is not present, replace override switch (Task 3-38).
8. Repeat steps 2. and 3. for limit switch S3, using pins E and F.
9. Repeat steps 2. and 3. on limit switch S4, using pins G and H.
10. Install instruction plate and secure using screws and washers.

FOLLOW-ON MAINTENANCE:

Install limit switch drive assembly
(Task 2-55)

**END OF TASK**

3-40. AUTOMATIC BRAKE ASSY - INSPECT

3-40**This task covers: Inspection****INITIAL SETUP****Personnel Rewired:**

67N, UH1 Helicopter Repairer
67T, UH60 Helicopter Repairer
91W, Medevac Medics

Equipment Condition:

Hoist installed in assembly stand
Limit switch assembly removed
Automatic brake assembly removed

Parts/Material:

None

Equipment Condition Para:

Task 3-5
Task 2-55
Task 3-43

Tools and Test Equipment:

None

References:

None

1. Inspect all parts for nicks, cracks, scratches and dents (refer to Task 2-11).
2. Inspect friction discs and brake discs for excessive wear scoring, warpage.
3. Inspect cam seat gears for missing teeth, pitting, galling and uneven wear.

FOLLOW-ON MAINTENANCE:

Repair automatic brake assy
(Task 342)

END OF TASK

3-41. AUTOMATIC BRAKE ASSY - ADJUST

3-41

This task covers: Adjustment**INITIAL SETUP****Personnel Required:**

67N, UH1 Helicopter Repairer
 67T, UH60 Helicopter Repairer
 91W, Medevac Medics

Parts/Materials:

Shim, 49001C8

Tools and Test Equipment:

Tool Kit, Aircraft Mechanic
 NSN 5180-00-323-4692
 Shop Set, Intermediate Maintenance
 NSN 4920-00-472-4183
 Automatic Brake Torque Fixture,
 42277-728

Equipment Condition:

Hoist in assembly stand
 Automatic brake assembly removed

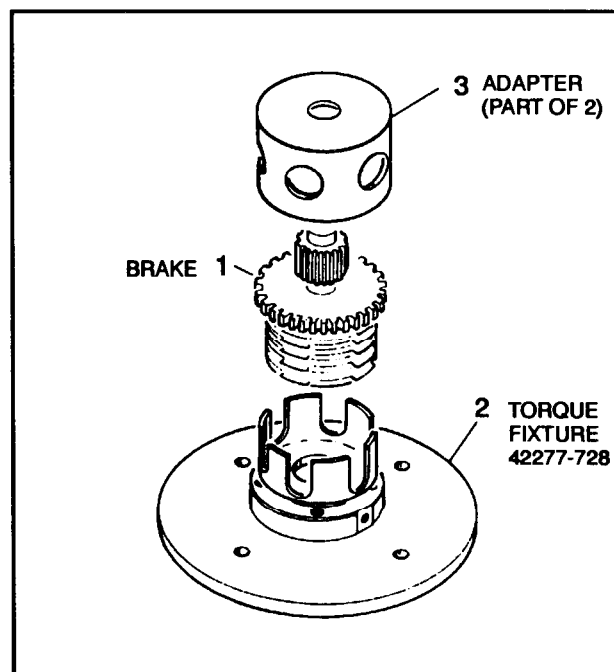
Equipment Condition Para:

Task 3-5
 Task 3-43

References:

None

1. Install automatic brake assembly (1) in Automatic Brake Torque Fixture (2). Install adapter (3) (supplied with fixture).
2. Using a torque wrench attached to adapter (3), rotate adapter clockwise and check slip torque of automatic brake assembly. **Brake shall slip at 4-55 in-lbs with 42277D176 friction disc installed or 29-32 in-lbs with alternate 42325-255 friction disc installed.**
3. Remove adapter (3) from brake assembly (1). Remove brake assembly from Automatic Brake Torque Fixture (2).

**GO TO NEXT PAGE**

4. If torque required to slip brake exceeds 55 in-lbs with 42277D176 friction disc or 32 in-lbs with alternate 42325-255 friction discs proceed as follows.
 - a. Disassemble automatic brake assembly in accordance with Task 3-42.

NOTE

Addition of automatic brake assembly shims lowers torque required to cause slippage.

- b. Add brake assembly shim(s) as required to adjust torque.
 - c. Reassemble brake assembly and repeat steps 1 through 4 to ensure proper brake operation.
5. If slippage occurs at less than 45 in-lbs with 42277D176 friction discs or 29 in-lbs with alternate 42325-255 friction discs installed proceed as follows.
 - a. Disassemble automatic brake assembly in accordance with Task 3-42.

NOTE

Removal of automatic brake assembly shims raises torque required to cause slippage.

- b. Remove brake assembly shim(s) as required to adjust clutch torque.
- c. Reassembly brake assembly and repeat steps 1 through 4 to ensure proper brake operation.

FOLLOW-ON MAINTENANCE:

Install automatic brake assembly
(Task 3-43)

END OF TASK

**THIS PAGE
INTENTIONALLY
LEFT BLANK**

This task covers: Disassembly, Cleaning, Inspection, Repair and Reassembly

INITIAL SETUP

Personnel Required:

67N, UH1 Helicopter Repairer
67T, UH60 Helicopter Repairer
91W, Medevac Medics

Equipment Condition:

Hoist installed in assembly stand
Automatic brake assembly removed

Parts/Materials:

Automatic Transmission Fluid (Item 3,
App. D)

Equipment Condition Para:

Task 3-5
Task 3-43

Tools and Test Equipment:

Tool Kit, Aircraft Mechanics
NSN 5180-00-323-4692
Shop Set, Intermediate Maintenance
NSN 4920-00472-4183
Automatic Brake Torque Fixture,
42277-728

References:

None

1. **Disassembly.**

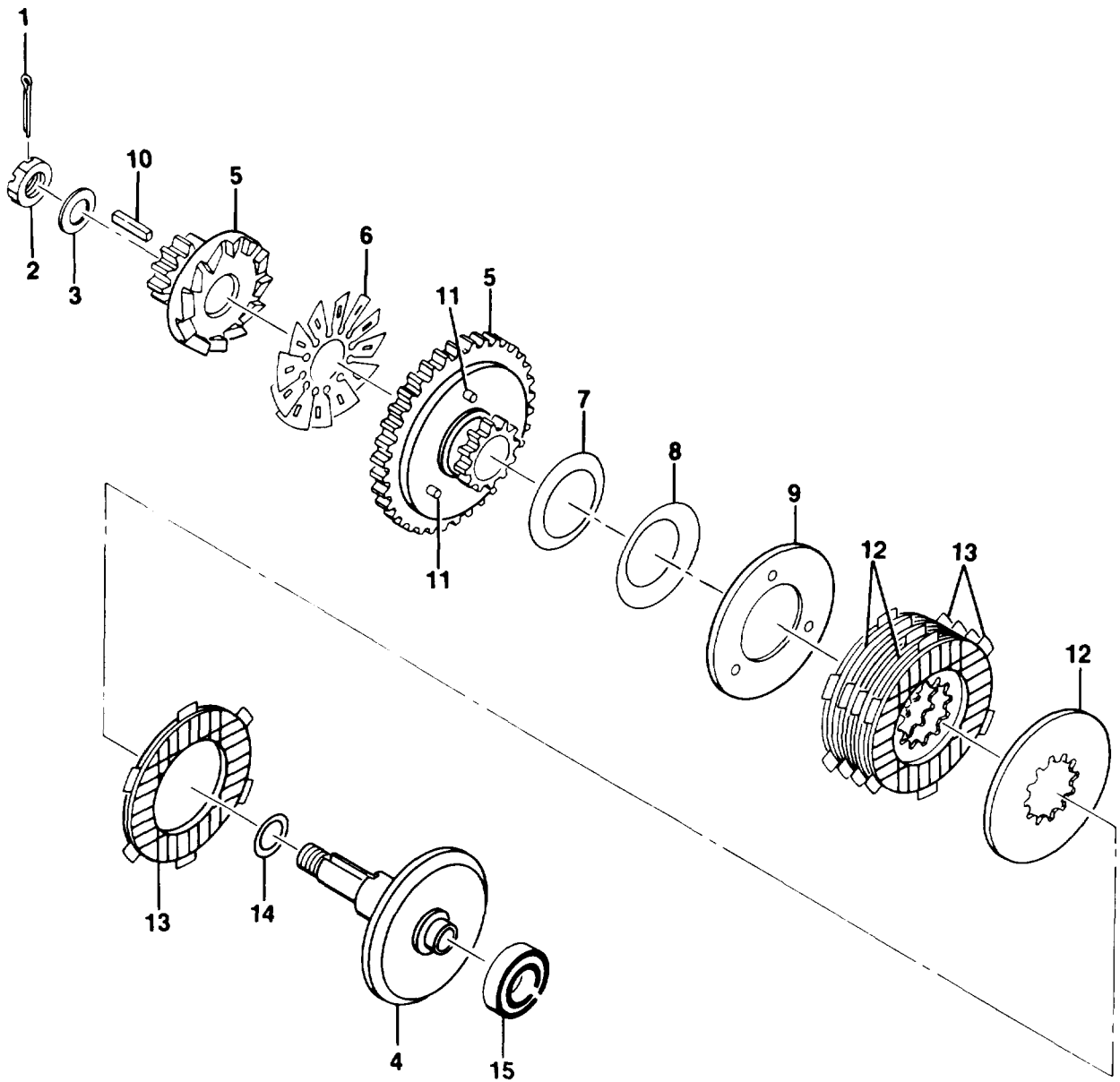
- a. Remove cotter pin (1), castellated nut (2) and washer (3) from automatic broke shaft (4).
- b. Remove gear cam seats (5), roller cage assembly (6), belleville springs (7, 8) and pressure plate (9). Remove key (10).
- c. Remove dowel pins (11) from gear cam seat (5).

NOTE

Note and record thickness of shim (14) to aid in reassembly.

- e. Slide brake discs (12 and friction discs (13) off automatic brake shaft (4). Remove shim (14).
- f. Remove ball bearing (15) from automatic brake shaft (4).

GO TO NEXT PAGE



GO TO NEXT PAGE

2. Cleaning.**WARNING**

Use solvent in a well-ventilated area. Avoid prolonged breathing of fumes. Keep away from open flame. Solvent is flammable.,

WARNING

Use approved personal protective equipment (goggles/face shield) when using compressed air. Air pressure is restricted to a maximum of 35 psi. Do not direct airstream towards self or other personnel.

CAUTION

If parts are not to be inspected immediately after cleaning, dip them in preservation oil to prevent rust spots,

- a. Ensure all old grease is removed from bearing. Lubricate with new grease at assembly.
- b. Wash remaining components in solvent and rinse thoroughly. Dry with compressed air.

3. Inspection.

- a. Inspect all parts for nicks, cracks and deep scratches (refer to Task 2-11).
- b. Inspect threaded parts for crossed, stripped and damaged threads.
- c. Inspect for loose and broken pins.
- d. Inspect frictions discs and brake discs for bent and broken tangs.
- e. Inspect cam seat gears for missing teeth, corrosion (refer to Task 2-11) and wear.
- f. Inspect cage roller for binding or missing rollers.

GO TO NEXT PAGE

**THIS PAGE
INTENTIONALLY
LEFT BLANK**

GO TO NEXT PAGE

4. **Repair.** Repair of parts is limited to removal of minor nicks, burrs, scratches or other surface damage using aluminum oxide cloth or fine abrasive. Clean part thoroughly after repair. If damage is extensive, or if minor repair will affect serviceability, replace the part.
5. **Reassembly.**
 - a. Lubricate ball bearing (15) with grease and install onto automatic brake shaft (4).
 - b. Soak friction discs (13) in transmission fluid for 10 minutes.
 - c. Install dowel pins (11) onto gear cam seat (5). **Pin height shall be 0.130-0.140 in. (0.330-0.356 cm).**
 - d. Place automatic brake shaft (4) into Automatic Brake Torque Fixture.

CAUTION

Do not inter-mix 42277D176 friction discs and alternate 42325-255 friction discs in automatic load brake assembly.

- e. Install two friction discs (13), two brake discs (12) and shim (14) onto shaft (4).
- f. Install belleville springs (7,8) and pressure plate (9) onto gear cam seat (5).
- g. Install gear cam seat (5) and remaining friction discs (13) and brake discs (12) onto automatic brake shaft (4). Align brake disc tangs.

NOTE

Ensure roller of cage assembly (6) rolls freely.

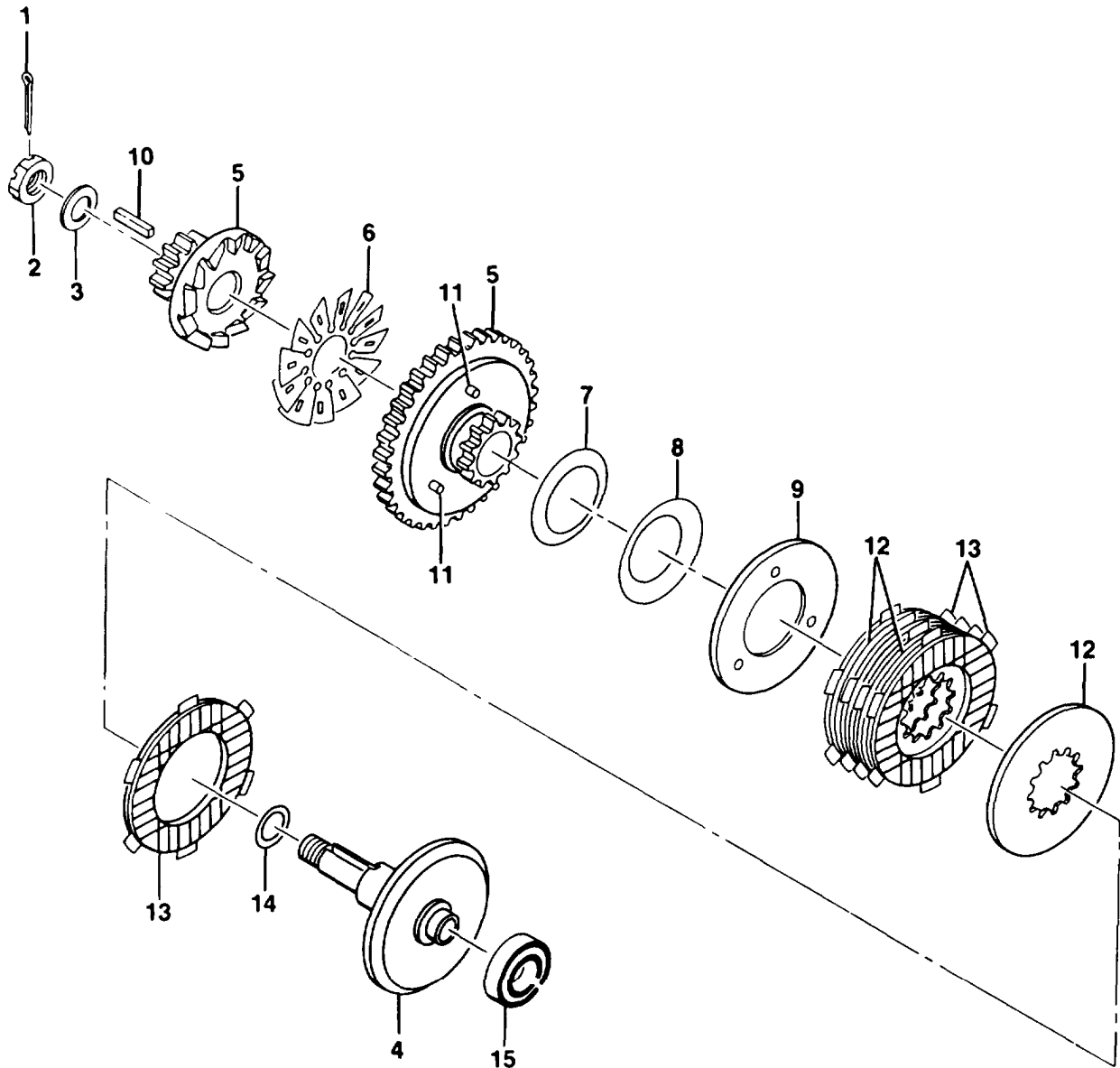
- h. Install key (10), roller cage assembly (6) and gear cam seat (5) onto shaft (4) ensuring alignment marks match.
- i. Install washer (3) and castellated nut (2).
- j. Perform adjustment Task 3-41 prior to installing cotter pin (1).

FOLLOW-ON MAINTENANCE:

Adjust automatic brake assembly
(Task 3-41)

Install automatic brake assembly
(Task 3-43)

GO TO NEXT PAGE



END OF TASK

3-43. AUTOMATIC BRAKE ASSY - REPLACE

3-43

This task covers: Removal and Installation**INITIAL SETUP****Personnel Required:**

67N, UH1 Helicopter Repairer
 67T, UH60 Helicopter Repairer
 91W, Medevac Medics

Parts/Materials:

Automatic Transmission Fluid (Item 3,
 App. D)
 Packing (2), NAS1593-152
 Bearing Ball P/N 9306K (Item 141, Fig C-18)

Tools and Test Equipment:

Tool Kit, Aircraft Mechanics
 NSN 5180-00-323-4692
 Shop Set, Intermediate Maintenance
 NSN 4920-00-472-4183

Equipment Condition:

Hoist installed in assembly stand
 Winch assembly drained
 Limit switch drive assembly removed

Equipment Condition Para:

Task 3-5
 Task 2-45
 Task 2-55

References:

None

1. Removal.**NOTE**

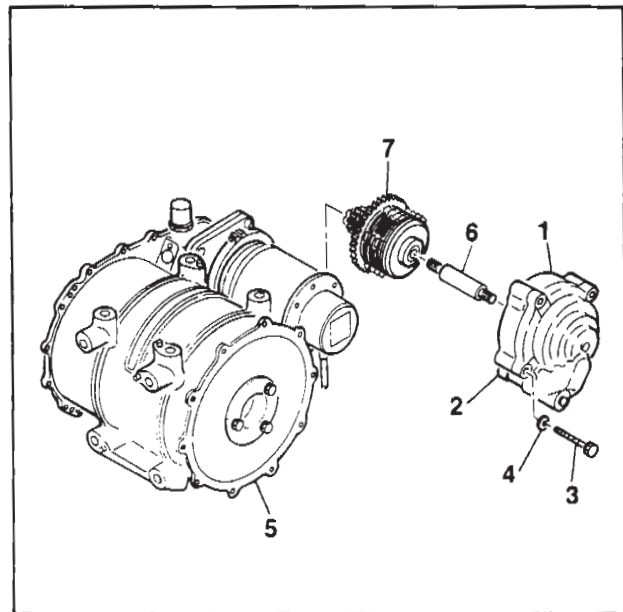
Using suitable material, block drum assembly to prevent rotation when removing automatic brake assembly.

- a. Remove pump housing assembly (1) and automatic brake housing (2) from winch assembly (5) by removing bolts (3) and washers (4).
- b. Remove shaft (6) from automatic brake assembly (7).

NOTE

Brake assembly may be difficult to remove from winch housing.

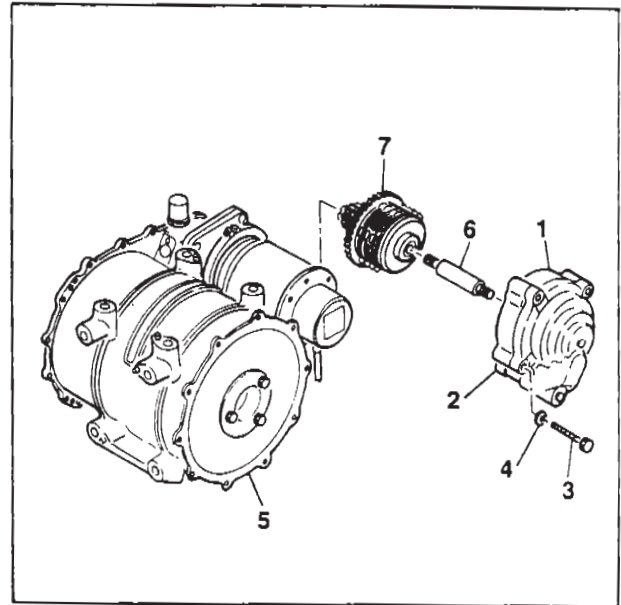
- c. Remove automatic brake assembly (7) from winch assembly (5).

**GO TO NEXT PAGE**

3-43. AUTOMATIC BRAKE ASSY - REPLACE (cont)**3-43****2. Installation..****CAUTION**

Ensure that bearing, ball P/N 9306K is installed prior to installing brake Assy into winch Assy.

- a. Install automatic brake assembly (7) into winch assembly (5).
- b. Install shaft (6) into automatic brake assembly (7).
- c. Install pump housing assembly (1) and automatic brake housing (2) onto winch assembly (5) and secure using bolts (3) and washers (4).

**FOLLOW-ON MAINTENANCE:**

Install limit switch drive assembly
(Task 2-55)
Service winch assembly
(Task 2-45)

END OF TASK

3-44. ELECTRICAL CABLES AND CONNECTORS - REPAIR

3-44

This task covers: Repair

INITIAL SETUP

Personnel Required:

67N, UH1 Helicopter Repairer
67T, UH60 Helicopter Repairer
68F, Aircraft Electrical Repairer
91W, Medevac Medics

Parts/Materials:

None

Equipment Condition:

Hoist installed in assembly stand

Equipment Condition Para:

Task 3-5

Tools and Test Equipment:

Tool Kit, Aircraft Mechanics
NSN 5180-00-323-4692
Shop Set, Intermediate Maintenance
NSN 4920-00-472-4183
Tool Kit, Electrical Repairer
NSN 5180-323-4915

References:

Aircraft Electric and Electronic Wiring
TM 55-1500-323-24

Repair of electrical cables and connectors is limited to repair of the cable cutter wiring harness. Refer to Task 2-66 for electrical schematic and harness repair.

FOLLOW-ON MAINTENANCE:

None

END OF TASK

3-45. ELECTRICAL CABLES AND CONNECTORS - REPLACE**3-45****This task covers: Removal and Installation****INITIAL SETUP****Personnel Required:**

67N, UH1 Helicopter Repairer
 67T, UH60 Helicopter Repairer
 68F, Aircraft Electrical Repairer
 91W, Medevac Medics

Equipment Condition:

Hoist installed in assembly stand

Parts/Materials:

None

Equipment Condition Para:

Task 3-5

Tools and Test Equipment:

Tool Kit, Aircraft Mechanics
 NSN 5180-W323-4692
 Shop Set, Intermediate Maintenance
 NSN 4920-00-472-4183
 Tool Kit, Electrical Repairer
 NSN 5180-00-323-4915

References

None

1. Refer to Task 2-67 for electrical schematic cable and connector replacement at AVUM level.
2. Replace flexible wiring harness in accordance with Task 3-35.
3. Refer to Task 3-24 for electrical cable schematic and procedurea for connector replacement at AVIM level.

FOLLOW-ON MAINTENANCE:

None

END OF TASK

Section VI. PREPARATION FOR STORAGE OR SHIPMENT

3-46. PREPARATION FOR STORAGE OR SHIPMENT

3-46

This task covers: Inspection, Preservation, and Packaging

INITIAL SETUP

Personnel Required:

67N, UH1 Helicopter Repairer (2)
 67T, UH60 Helicopter Repairer (2)
 91W, Medevac Medics

Equipment Condition:

Hoist installed in assembly stand
 Boom head assembly drained
 Winch assembly drained

Parts/Materials:

None

Equipment Condition Para:

Task 3-5
 Task 2-18
 Task 2-45

Tools and Test Equipment:

Shipping Container, 42305R11

References:

General Aircraft Maintenance Manual
 TM 1-1500-204-23 (Series)
 Army Material Maintenance Concepts and Policies
 AR750-1
 Preservation and Packaging
 MIL-STD-1188
 Material Condition Marking
 MIL-STD-129

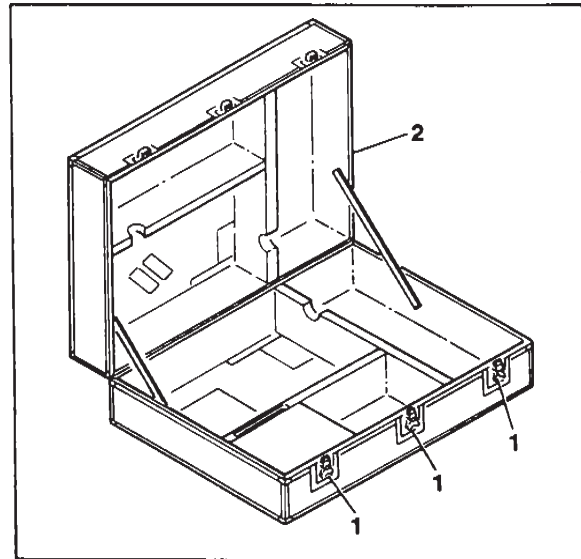
1. **Inspection.** Inspect hoist for damage in accordance with inspection criteria in Task 2-11. If hoist has been damaged, report damage on a two material condition tags in accordance with MIL-STD-129. Attach one tag directly onto hoist. Attach second tag to the outside of the reusable shipping container after installation of hoist. Ensure tags are secured in such a manner that will afford maximum protection from handling and weather.
2. **Preservation.** Rescue hoist shall be preserved in accordance with MIL-STD-1 188, Level A.
3. **General Information.** For general technical information on preparation for storage or shipment, refer to TM 1-1500-204-23 (Series). For regulatory requirements pertaining to equipment placed in administrative storage, refer to AR750-1 .

GO TO NEXT PAGE

3-46. PREPARATION FOR STORAGE OR SHIPMENT**3-46****4. Packaging.****WARNING**

When hoist is packaged for shipment or storage, refire kit, P/N 42277E182. Reference in change 3, page C-3-2 Item Number 74A is to be removed from the cable cutter. The cable cutter, P/N 42277E336 may be left in hoist but the refire kit which is an explosive charge and component of the cable cutter must be removed prior to shipment or storage. In addition storage case should be marked externally to indicate that explosive charge has been removed.

- a. Place rescue hoist reusable shipping container, Part Number 42305R11 on a flat surface. Allow adequate work space for installation of rescue hoist.
- b. Lift three overcenter latch handles (1) and unlatch to release top of shipping container (2).
- c. Grasp top of shipping container (2) and lift up to open.
- d. With a helper, lift hoist and place into shipping container.
- e. Secure cable hook in container using internal retaining strap.
- f. Ensure material condition tag is securely attached to hoist. Close top of shipping container (2) and secure using three overcenter latch handles (1).

**FOLLOW-ON MAINTENANCE:**

None

END OF TASK

CHAPTER 4**PACKAGING****4-1. PRESERVATION, PACKING AND MARKING.**

a. Output components will be preserved, packed, and marked in accordance with the Delivery Order//Contract, Depot Maintenance Interservice Support Agreement (DMISA), Statement of Work (SOW) Memorandum of Agreement or other authorization documents, and the accompanying DA Form 2410.

b. Output components from organic depot Maintenance and Overhaul (M&O) programs will be packaged in accordance with the Army Master Data File Retrieval Microform System (ARMS) Packaging File and marked in accordance with MIL-STD-129. Components for which a special or multi-application container is specified will be packed in the assigned container. All other components will be packaged level A/B unless weight and dimension requirements of MIL-STD-2073-1 & 2 specify a wood container. The level of packaging shall be level A/A when a special/multi-application reusable container or wooden container is specified. When components are received at the overhaul maintenance facility, the container will be inspected for serviceability in accordance with Chapter 2, TB 55-8100-200-24. Containers will be requisitioned as required to replace missing, improper, or unserviceable containers to ensure availability of container when component is returned from overhaul maintenance facility. The AMCOM Packaging and Transportability Branch must approve waivers, deviations, and container substitution. Written communication should be submitted to U.S. Army Aviation and Missile Command, ATTN: AMSAM-MMC-LS-DP, Redstone Arsenal AL, 35898. Telephone inquiries may be made to Commercial (256) 842-8665 or DSN 788-8665.

4-2. All contractual matters shall be through the assigned Contracting Officer (KO). Technical communication should be submitted to U.S. Army Aviation and Missile Command, ATTN: AMSAM-MMC-MA-NP, Redstone Arsenal AL, 35898. Telephone inquiries may be made to Commercial (256) 842-8665 or DSN 788-8665.

APPENDIX A**REFERENCES****A - 1. Dictionaries of Terms and Abbreviations**

AR 310-25	Dictionary of United States Army Terms
AR 310-50	Authorized Abbreviations and Brevity Codes

A - 2. Publication Index

DA PAM 25-30	Consolidated Index of Army Publications and Blank Forms
--------------	---

A - 3. Logistics and Storage

TM 743-200-1	Storage and Materials Handling
--------------	--------------------------------

A - 4. Maintenance of Supplies and Equipment

AR 750-1	Army Material Maintenance Concepts and Policies
DA PAM 738-751	Functional Users Manual for the Army Maintenance Management System - Aviation (TAMMS-A)
TM 1-1500-204-23 (Series)	General Aircraft Maintenance Manual
TM 55-1500-323-24	Aircraft Electric and Electronic Wiring
TM 55-1500-345-23	Painting and Marking of Army Aircraft
TM 1-1500-343-23	Avionic Cleaning and Corrosion Prevention/Control
TM 55-1520-210-23-2	UH1 Series Helicopter Maintenance
TM 55-1520-237-23-4	UH60 Series Helicopter Maintenance
TM 1-1500-344-23	Aircraft Weapons Systems Cleaning and Corrosion Control
TM 9-1370-203-20&P	Military Pyrotechnics
TM 9-1370-203-34&P	Military Pyrotechnics

A - 5. Other Publications

AR 420-90	Fire Prevention and Protection
AR 55-38	Reporting of Transportation Discrepancies in Shipments
AR 700-58	Packaging Improvement Report
DA PAM 310-13	Military Publications Posting and Filing
FM-21-11	First Aid for Soldiers
TB 43-180	Calibration Requirements for the Maintenance of Army Material
TM 750-244-1-4	Procedures for the Destruction of Aviation Ground Support Equipment (FSC 4920) to Prevent Enemy Use

APPENDIX B

MAINTENANCE ALLOCATION CHART

Section I. INTRODUCTION

B-1. Maintenance Allocation Chart.

a. The Maintenance Allocation Chart (MAC) assigns maintenance functions in accordance with the Three Levels of Maintenance concept for Army aviation. These maintenance levels (categories) - Aviation Unit Maintenance (AVUM), Aviation Intermediate Maintenance (AVIM) and Depot Maintenance - are depicted on the MAC as:

AVUM, which corresponds to an O Code in the Repair Parts and Special Tools List (RPSTL)

AVIM, which corresponds to an F Code in the Repair Parts and Special Tools List (RPSTL)

DEPOT, which corresponds to an D Code in the Repair Parts and Special Tools List (RPSTL)

b. The maintenance to be performed below depot and in the field is described as follows:

(1) Aviation Unit Maintenance (AVUM) activities will be staffed and equipped to perform high frequency "On-Aircraft" maintenance tasks required to maintain or return aircraft systems to a serviceable condition. The maintenance capability of the AVUM will be governed by the Maintenance Allocation Chart (MAC) and limited by the amount and complexity of ground support equipment (GSE), facilities required, authorized manning strength and critical skills available. The range and quantity of authorized spare modules / components will be consistent with the mobility requirements dictated by the air mobility concept. (Assignments of maintenance tasks to divisional company size aviation units will consider the overall maintenance capability of the division, the requirement to conserve personnel and equipment resources and air mobility requirements).

(a) Company Size Aviation Units: Perform those tasks which consist primarily of preventive maintenance and maintenance repair and replacement functions associated with sustaining a high level of aircraft operational readiness. Perform maintenance inspections and servicing to include preflight daily, intermediate, periodic (or phased) and special inspections as authorized by the MAC or higher headquarters. Identify the cause of equipment / system malfunctions using applicable technical manual troubleshooting instructions, built-in test equipment (BITE), installed aircraft instruments, or test, measurement and diagnostic equipment (TMDE). Replace worn or damaged modules / components that do not require complex adjustments or system alignment and which can be removed / installed with available skills, tools and ground support equipment. Perform operational and continuity checks and make minor repairs to the electrical system. Inspect, service and make operational, capacity and pressure checks to hydraulic systems. Perform servicing functional adjustments and minor repair / replacement to the flight control, propulsion, power train and fuel systems. Accomplish air frame repair that does not require extensive disassembly, jiggling or alignment. The manufacture of air frame parts will be limited to those items which can be fabricated with tools and equipment found in current air mobile tool and shop sets. Evacuate unserviceable modules / components and end items beyond the repair capability of AVUM to the supporting AVIM.

(b) Less than Company Size Aviation Units: Aviation elements organic to brigade, group, battalion headquarters and detachment size units are normally small and have less than ten aircraft assigned. Maintenance tasks performed by these units will be those which can be accomplished by the aircraft crew chief or assigned airman repairman and will normally be limited to preventive maintenance, inspections, servicing spot painting, stop drilling, application of nonstress patches, minor adjustments, module / component fault diagnosis and replacement of selected modules / components. Repair functions will normally be accomplished by the supporting AVIM unit.

(2) Aviation Intermediate Maintenance (AVIM) provides mobile, responsive "One-Stop" maintenance support. (Maintenance functions which are not conducive to sustaining air mobility will be assigned to depot maintenance), AVIM

may perform all maintenance functions authorized to be done at AVUM. Repair of equipment for return to user will emphasize support or operational readiness requirements. Authorized maintenance includes replacement and repair of modules / components and end items which can be accomplished efficiently with available skills, tools and equipment. AVIM establishes the Direct Exchange (DX) program for AVUM units by repairing selected items for return to stock when such repairs cannot be accomplished at the AVUM level. The AVIM level inspects, troubleshoots, performs diagnostic tests, repairs, adjusts, calibrates and aligns aircraft system modules / components. AVIM units will have capability to determine the serviceability of specified modules/ components removed prior to the expiration of the Time Between Overhaul (TBO) or finite life. Module / component disassembly and repair will support the DX program and will normally be limited to tasks requiring cleaning and the replacement of seals, fittings and items of common hardware. Air frame repair and fabrication of parts will be limited to those maintenance tasks which can be performed with available tools and test equipment. Unserviceable repairable modules / components and end items which are beyond the capability of AVIM to repair will be evacuated to Depot Maintenance. AVIM will perform aircraft weight and balance inspections and other special inspection which exceed AVUM capability. Provides quick response maintenance support, including aircraft recovery and air evacuation, on-the-job training and technical assistance through the use of mobile maintenance contact teams. Maintains authorized operational readiness float aircraft. Provides collection and classification services for serviceable / unserviceable material. Operates a cannibalization activity in accordance with AR 750-50. (The aircraft maintenance company within the maintenance battalion of a division will perform AVIM functions consistent with air mobility requirements and conservation of personnel and equipment resources. Additional intermediate maintenance support will be provided by the supporting non-divisional AVIM unit).

B-2. Use of the Maintenance Allocation Chart (Section II)

NOTE

Nomenclature used throughout the MAC are approved item names. Those terms / nomenclatures expressed in parentheses are generic in nature and are not to be considered as official terminology.

a. The Maintenance Allocation Chart assigns maintenance functions based on past experience and the following consideration:

- (1) Skills available.
- (2) Work time Required.
- (3) Tools and test equipment required and / or available.

b. The assigned levels of maintenance authorized to perform a maintenance function are indicated.

c. A maintenance function assigned to a maintenance category will automatically be authorized to be performed at any higher maintenance category.

d. A maintenance function that cannot be performed at the assigned category of maintenance for any reason may be evacuated to the next higher maintenance category. Higher maintenance categories will perform the maintenance functions of lower maintenance categories when required or directed by the commander that has the authority to direct such tasking.

e. The assignment of a maintenance function will not be construed as authorization to carry the related repair parts or spares in stock. Information to requisition or otherwise secure the necessary repair parts will be as specified in the associated Repair Parts and Special Tools List (RPSTL).

f. Normally there will be no deviation from the assigned level of maintenance. In cases of operational necessity, maintenance functions assigned to a maintenance level may, on a one-time basis and at the request of the lower maintenance level, be specifically authorized by the maintenance officer of the level of maintenance to which the function is assigned. The special tools, equipment, etc. required by the lower level of maintenance to perform this function will be furnished by

the maintenance level to which the function is assigned. This transfer of a maintenance function to a lower maintenance level does not relieve the higher maintenance level of the responsibility for the function. The higher level of maintenance has the authority to determine; (1) if the lower level is capable of performing the work, (2) if the lower level requires assistance, technical supervision, and on site inspection, and (3) if the authorization will be granted.

g. Changes to the Maintenance Allocation Chart will be based on continuing evaluation and analysis by responsible technical personnel and on reports received from field activities.

B-3. Maintenance Functions. Maintenance functions will be limited to and defined as follows:

a. Inspect. To determine the serviceability of an item by comparing its physical, mechanical, and / or electrical characteristic with established standards through examination (e.g., by sight, sound or feel).

b. Test. To verify serviceability by measuring the mechanical pneumatic, hydraulic or electrical characteristics of an item and comparing those characteristics with prescribed standards.

c. Service. Operations required periodically to keep an item in proper operating condition, i.e., to clean (includes decontaminate, when required), to preserve, to drain, to paint, or to replenish fuel, lubricants, chemical fluids, or gases.

d. Adjust. To maintain or regulate, within prescribed limits, by bringing into proper or exact position, or by setting the operating characteristics to specified parameters,

e. Align. To adjust specified variable elements of an item to bring about optimum or desired performance.

f. Calibrate. To determine and cause corrections to be made or to be adjusted on instruments or test, measuring and diagnostic equipments used in precision measurement. Consists of comparisons of two instruments, one of which is a certified standard of known accuracy, to detect and adjust any discrepancy in the accuracy of the instrument being compared.

g. Remove/Install. To remove and install the same item when required to perform service or other maintenance functions. Install may be the act of emplacing, seating, or fixing into position a spare, repair part, or module (component or assembly) in a manner to allow the proper functioning of an equipment or system.

h. Replace. To remove an unserviceable item and install a serviceable counterpart in its place. "Replace" is authorized by the MAC and is shown as the 3d position code of the SMR code.

i. Repair. The application of maintenance services, including fault location/ troubleshooting removal installation, and disassembly / assembly³ procedures, and maintenance actions⁴ to identify troubles and restore serviceability to an item by correcting specific damage, fault, malfunction or failure in a part, subassembly, module (component or assembly), end item or system.

NOTES:

- 1 Services - inspect, test, service, adjust, align, calibrate, and / or replace.
- 2 Fault locate / troubleshoot - The process of investigating and detecting the cause of equipment malfunctioning the act of isolating a fault within a system or unit under test (UUT).
- 3 Disassemble / assemble - encompasses the step-by-step taking apart (or breakdown) of a spare / functional group coded item to the level of its least componency identified as maintenance significant (i.e., assigned an SMR code) for the category of maintenance under consideration.
- 4 Actions - welding, grinding, riveting, straightening, facing, remachining and / or resurfacing.

j. **Overhaul.** That maintenance effort (service / action) prescribed to restore an item to a completely serviceable / operational condition as required by maintenance standards in appropriate technical publications (i.e., DMWR), Overhaul is normally the highest degree of maintenance performed by the Army. Overhaul does not normally return an item to like-new condition.

k. **Rebuild. Consists** of those services / actions necessary for the restoration of unserviceable equipment to a like-new condition in accordance with original manufacturing standards. Rebuild is the highest degree of material maintenance applied to Army equipment. The rebuild operation includes the act of returning to zero those age measurements (hours / miles, etc.) considered in classifying Army equipment / components.

B-4. Functional Groups (Columns 1 and 2.) The functional groupings shown in the sample below identify maintenance significant components, assemblies, subassemblies and modules with the next higher assembly.

GROUP NUMBER	DESCRIPTION	GROUP NUMBER	DESCRIPTION
04	AUXILIARY POWER UNIT	0405	ELECTRICAL SYSTEM
0401	ENGINE GENERAL Servicing, handling, inspection requirements, lubrication charts, overhaul and retirement schedules. External lines and hoses. (As applicable)	0406	OIL SYSTEM
0402	COMBUSTION SECTION Liners, nozzles, stators, rotor, seals, couplings, blades and housing.	0407	DRIVE SYSTEM
0403	POWER-TURBINE (POWER TURBINE MODULE) Nozzles, rotors, blades, exit guide vanes, exhaust frame, drive shaft, bearings, seals, external lines and hoses.	0408	MISCELLANEOUS EQUIPMENT (As applicable).
0404	FUEL SYSTEM Fuel control, fuel boost pump, governors, fuel filter assembly, sequence valve, fuel manifold, fuel nozzle, external lines and hoses.		

B-5. Maintenance Function (Column 3). Column 3 lists the functions to be performed on the items listed in column 2.

B-6. Maintenance Categories and Work Times (Column 4). The maintenance categories (levels) AVUM, AVIM and DEPOT are listed on the Maintenance Allocation Chart with individual columns that include the work times for maintenance functions at each maintenance level. Work time presentations such as "O. 1" indicate the average time it requires a maintenance level to perform a specified maintenance function. If a work time has not been established, the columnar presentation shall indicate "-.-". Maintenance levels higher than the level of maintenance indicated are authorized to perform the indicated function. Numbers in parentheses identify the correspondingly numbered remarks in Section IV.

B-7. Tools and Test Equipment (Column 5 and Section III). Common tool sets (not individual tools), special tools, test and support equipment required to perform maintenance functions are listed in Section 111 with a reference number to permit cross-referencing to column 5 in the MAC. In addition, the maintenance category authorized to use the device is listed along with the item National Stock number (NSN) and, if applicable, the tool number to aid in identifying the tool / device.

B-8. Remarks (Column 6 and Section IV). Remarks and other notes, if applicable (identified by a number in parentheses in the applicable column) are listed in Section IV to provide a ready reference to the definition of the remark / note.

Section II

MAINTENANCE ALLOCATION CHART

NOMENCLATURE OF END ITEMS

42305R1 High Performance Rescue Hoist Assembly

(1) GROUP NUMBER	(2) COMPONENT OR ASSEMBLY	(3) MAINTENANCE FUNCTION	(4) MAINTENANCE CATEGORY AVUM AVIM DEPOT			(5) TOOLS AND EQUIPMENT	(6) REMARKS
00	HIGH PERFORMANCE RESCUE HOIST	INSPECT	- - -	(1)			
		TEST	- - - (2)				
		SERVICE	- - - (3)			1	
		ADJUST		- - -		1, 4, 6	
		REPAIR	- - - (7)	- - - (4,7)	- - -	1, 2, 4, 6, 7	A
01	PENDANT ASSY, CONTROL	INSPECT (1)	- - -				
		TEST			- - -		
		REPAIR		- - - (7)		2, 4, 6	A
		REPLACE	- - -			7	A
02	BOOM HEAD ASSY	INSPECT	- - - (1)			7	
		SERVICE	- - - (3)			1, 3	
		ADJUST		- - -		7	
		REPAIR	- - - (3,7)	- - - (3,7)	- - -	1, 3, 4, 6, 7	A, B
		REPLACE	- - - (3)			1, 3, 7	A, B

MAINTENANCE ALLOCATION CHART (cont)

NOMENCLATURE OF END ITEMS

42305R1 High Performance Rescue Hoist Assembly

(1) GROUP NUMBER	(2) COMPONENT OR ASSEMBLY	(3) MAINTENANCE FUNCTION	(4) MAINTENANCE CATEGORY AVUM AVIM DEPOT	(5) TOOLS AND EQUIPMENT	(6) REMARKS
0201	BRAKE ASSY	INSPECT	--	7	
		REPAIR	-- (3,7)	1, 4, 7	A
		ADJUST	-- (5)	1, 4, 5, 7	
		REPLACE	--	1, 4, 7	A,B
0202	CLUTCH ASSY	INSPECT	--	7	
		REPAIR	-- (3,7)	1, 4, 7	A
		ADJUST	-- (5)	1, 4, 5, 7	
		REPLACE	--	1, 4, 7	A, B
0203	CABLE CUTTER ASSY	INSPECT	-- (1)		
		REPAIR	--	1, 7	A, B
		REPLACE	--	1, 7	A, B
0204	ACTUATOR ASSY (UP LIMIT)	INSPECT	-- (1)		
		ADJUST	--	1,7	
		REPLACE	--	1,7	A
0205	MICROSWITCH ASSY (FULL UP)	TEST	--	12	
		REPLACE	--	1, 2, 4, 7	A

MAINTENANCE ALLOCATION CHART (cont)
 NOMENCLATURE OF END ITEMS

42305R1 High Performance Rescue Hoist Assembly

(1) GROUP NUMBER	(2) COMPONENT OR ASSEMBLY	(3) MAINTENANCE FUNCTION	(4) MAINTENANCE CATEGORY			(5) TOOLS AND EQUIPMENT	(6) REMARKS
			AVUM	AVIM	DEPOT		
0206	FLEX SHAFT ASSY	INSPECT		- - -		7	
		REPLACE		- - -		1, 4, 7	A
03	CONTROL PANEL ASSY	TEST			- - -		
		REPAIR		- - - (6,7)	- - -	7	A
		REPLACE	- - -			1, 7, 9	A
0301	BLOWER ASSY/ DC MOTOR ASSY	REPLACE		- - -		1, 2, 4, 7	A
		REPAIR			- - -		
04	SUPPORT ASSY, BOOM POSITION	INSPECT	- - - (1)				
		ADJUST	- - -			1	
		REPAIR	- - - (3,7)	- - - (3,7)	- - -	1, 2, 3, 4, 7	A
		REPLACE		- - -			A
0401	HEIGHT ADJUSTER ASSY	INSPECT	- - - (1)				
		REPAIR	- - - (3,7)			1, 3	A
		REPLACE	- - - (3)				A

MAINTENANCE ALLOCATION CHART (cont)

NOMENCLATURE OF END ITEMS							
42305R1 High Performance Rescue Hoist Assembly							
(1)	(2)	(3)	(4)			(5)	(6)
GROUP NUMBER	COMPONENT OR ASSEMBLY	MAINTENANCE FUNCTION	MAINTENANCE CATEGORY AVUM	AVIM	DEPOT	TOOLS AND EQUIPMENT	REMARKS
040101	QUICK DISCONNECT (UPPER SUPPORT)	INSPECT	- - -				
			(1)				
0402	SUPPORT ASSY, UPPER	REPLACE	- - -			1, 3	A
		INSPECT	- - -				
			(1)				
0403	SUPPORT ASSY, LOWER	REPAIR	- - -				A
			(7)				
		REPLACE		- - -		1, 4	A
0404	REACTION ARM ASSY	INSPECT	- - -			7	
			(1)				
		REPAIR	- - -	- - -	- - -	7	A
		(7)	(7)				
040401	QUICK DISCONNECT (REACTION ARM)	REPLACE		- - -		1, 4	A
		INSPECT	- - -				
			(1)				
0405	WIRING HARNESS	REPLACE		- - -		1, 4, 7	
		INSPECT	- - -				
				(1)			
		REPLACE		- - -		1, 2, 4	A

MAINTENANCE ALLOCATION CHART (cont)

NOMENCLATURE OF END ITEMS								
42305R1 High Performance Rescue Hoist Assembly								
(1)	(2)	(3)	(4)			(5)	(6)	
GROUP NUMBER	COMPONENT OR ASSEMBLY	MAINTENANCE FUNCTION	MAINTENANCE CATEGORY AVUM	AVIM	DEPOT	TOOLS AND EQUIPMENT	REMARKS	
05	WINCH ASSY	INSPECT	-- (1)					
		SERVICE	-- (3)			1, 3, 7		
		ADJUST	--					
		ALIGN	--			7		
		REPAIR	-- (3,7)	-- (3,7)	--		1, 2, 4, 7	A
		REPLACE		--			1, 4	A
0501	MOTOR, ELECTRIC	INSPECT	-- (1)					
		REPLACE	--			1, 7	A	
		REPAIR			--			
0502	INERTIA DUMP ASSY	INSPECT	-- (1)			7		
		REPLACE	--			1, 3, 7	A	
		REPAIR			--			

MAINTENANCE ALLOCATION CHART (cont)

NOMENCLATURE OF END ITEMS								
42305R1 High Performance Rescue Hoist Assembly								
(1)	(2)	(3)	(4)			(5)	(6)	
GROUP NUMBER	COMPONENT OR ASSEMBLY	MAINTENANCE FUNCTION	AVUM	AVIM	DEPOT	TOOLS AND EQUIPMENT	REMARKS	
0503	DRIVE ASSY, LIMIT SWITCH	INSPECT	- - - (1)			7		
		ADJUST	- - -			1, 3, 7, 8, 11		
		REPLACE	- - -			1, 3, 7	A	
		REPAIR		- - - (7)			1, 2, 4, 6, 7	A
		TEST		- - -			1, 4, 6, 7	
0504	AUTOMATIC BRAKE ASSY	INSPECT		- - -		7		
		ADJUST		- - - (5)			1, 4, 7, 10	
		REPAIR		- - - (3,7)			1, 4, 7, 10	A
		REPLACE		- - - (3)			1, 4, 7	A
0505	CABLE HOOK ASSY	INSPECT	- - - (1)			7		
		REPAIR	- - - (7)			1, 3	A	
		REPLACE	- - -			1, 7	A	
0506	HOIST CABLE ASSY	INSPECT	- - - (1)			8	C	
		REPLACE	- - -			1, 3, 7, 8, 11	A, C	

MAINTENANCE ALLOCATION CHART (cont)

NOMENCLATURE OF END ITEMS								
42305R1 High Performance Rescue Hoist Assembly								
(1)	(2)	(3)	(4)			(5)	(6)	
GROUP NUMBER	COMPONENT OR ASSEMBLY	MAINTENANCE FUNCTION	MAINTENANCE CATEGORY	AVUM	AVIM	DEPOT	TOOLS AND EQUIPMENT	REMARKS
0507	SHOE, LEVEL WIND	INSPECT	- . -				7	
		REPLACE	- . -				1, 3, 7	A
0508	DRUM ASSY	INSPECT	- . -				7	
		ALIGN	- . -				1, 3, 7, 8, 11	
06	ELECTRICAL CABLES/CONNECTORS	INSPECT	- . - (1)					
		REPAIR	- . - (7)	- . - (7)		- . -	1, 2, 4, 7	A
		REPLACE	- . -	- . -		- . -	1, 2, 3, 4, 7	A

Section III

TOOL AND TEST EQUIPMENT REQUIREMENTS

NOMENCLATURE OF END ITEMS

42305R1 High Performance Rescue Hoist Assembly

TOOL/TEST EQUIPMENT REFERENCE CODE	MAINTENANCE CATEGORY	NOMENCLATURE	NATIONAL/NATO STOCK NUMBER	TOOL NUMBER
1	AVUMJAVIM	Tool Kit, Aircraft Mechanics	5180-00-323-4692	SC5180-99-CL-A01
2	AVUMJAVIM	Tool Kit, Electrical Repairer	5180-00-323-4915	SC5180-99-CL-A06
3	AVUM	Tool Set, Aviation Unit Maintenance (Set No. 2)	4920-00-567-0476	SC4920-99-CL-A92
4	AVIM	Shop Set, Intermed- iate Maintenance	4920-00-472-4183	SC4920-99-CL-A91
5	AVIM	Holding Fixture, Clutch and Brake		42277-716
6	AVUMJAVIM	Multimeter		- - -
7	AVUMJAVIM	Assembly Stand		42277-808 (or equiv.)
8	AVUM	Cable Spool		42277-730 (or equiv.)
9	AVUM	Pliers		44191D192
10	AVIM	Torque Fixture, Automatic Brake		42277-728
11	AVUMJAVIM	Ground Power Unit. 28 vdc		- - -

Section IV

REMARKS

NOMENCLATURE OF END ITEMS

42305R1 High Performance Rescue Hoist Assembly

REFERENCE

CODE

REMARKS / NOTES

- | | |
|-----|--|
| (1) | Visible Inspection without detailed disassembly |
| (2) | Functional Test at AVUM/AVIM - Hoist installed in helicopter |
| (3) | Replace packings and seals |
| (4) | Repair at AVIM includes complete breakdown of the Control Pendant Assembly, Brake and Clutch Assemblies, Limit Switch Drive Assembly, and Automatic Brake Assembly |
| (5) | Torque Slip Adjustment using the Clutch and Brake Holding Fixture |
| (6) | Repair limited to removal and replacement of the Blower Assembly /DC Motor |
| (7) | Refer to TM 55-1500-343-23 |
| A | All repair and replacement of parts performed at AVUM or AVTM is limited to authorized items ("O or "F" SM&R coded components) listed in Appendix C. |
| B | Cable cutter contains an explosive cartridge. Use care when handling. |
| c | Use Cable Spool (or acceptable substitute) to prevent damage to cable. |
-

APPENDIX C

AVIATION UNIT AND INTERMEDIATE MAINTENANCE

REPAIR PARTS AND SPECIAL TOOLS LIST
(INCLUDING DEPOT MAINTENANCE REPAIR PARTS)

Section I. INTRODUCTION

C-1. Scope. This RPSTL lists and authorizes repair parts, special tools, special test, measurement, and diagnostic equipment (TMDE), and other special support equipment required for performance of aviation unit maintenance (AVUM) and aviation intermediate maintenance (AVIM) of the High Performance Rescue Hoist Assembly. It authorizes the requisitioning, issue and disposition of repair parts, spares and special tools as indicated by the source, maintenance and recoverability (SMR) codes.

C-2. General. In addition to Section I, Introduction, this Repair Parts and Special Tools List is divided into the following sections:

a. **Section II. Repair Parts List.** A list of spare and repair parts authorized for use in the performance of maintenance. The list also indicates parts which must be removed for replacement of the authorized parts. Parts Lists are composed of fictional groups in numeric sequence with the parts in each group listed in ascending figure and item number sequence. Bulk materials are listed by item name in FIG. BULK at the end of the section.

b. **Section III. Special Tools List.** A list of special tools, special TMDE, and other special support equipment authorized for the performance of maintenance.

c. **Section IV. National Stock Number and Part Number Index.** A list in Federal Supply Class (FSC) sequence, of all National stock numbers (NSN) appearing in the listings, followed by a list in alphanumeric sequence of all part numbers appearing in the listings. National stock numbers and part numbers are cross-referenced to each illustration figure and item number appearance.

C-3. Explanation of Columns (Sections II and III).

a. **ITEM NO. (Column (1)).** The number used to identify item called out in the illustration.

b. **SMR CODE (Column (2)).** The Source, Maintenance and Recoverability (SMR) code is a 5-position code containing supply / requisitioning information, maintenance category authorization criteria and disposition instruction.

(1) Source Code. Source codes indicate the manner of acquiring support items for maintenance, repair, or overhaul of end items. Source codes are entered in the first and second positions of the Uniform SMR Code format as follows:

Code	Definition
PA	Item procured and stocked for anticipated or known usage.
PB	Item procured and stocked for insurance purpose because essentiality dictates that a minimum quantity be available in the supply system.

Code	Definition
PC	Item procured and stocked and which otherwise would be coded PA except that it is deteriorative in nature.
PD	Support item, excluding support equipment, procured for initial issue or outfitting and stocked only for subsequent, or additional initial issues or outfitting. Not subject to automatic replenishment.
PE	Support equipment procured and stocked for initial issue or outfitting to specified maintenance repair activities.
PF	Support equipment which will not be stocked but which will be centrally produced on demand.
PG	Item procured and stocked to provide for sustained support for the life of the equipment. It is applied to an item peculiar to the equipment which, because of probable discontinuance or shutdown of production facilities would prove uneconomical to reproduce at a later time.
KD	An item of a depot overhaul / repair kit and not purchased separately. Depot kit defined as a kit that provides items required at the time of overhaul or repair.
KF	An item of a maintenance kit and not purchased separately. Maintenance kit defined as a kit that provides an item that can be replaced at organizational or intermediate levels of maintenance.
KB	Item included in both a depot overhaul kit and a maintenance kit.
MO	Item to be manufactured or fabricated at the organizational level.
MF	Item to be manufactured or fabricated at the direct support maintenance level.
MD	Item to be manufactured or fabricated at the depot maintenance level.
AO	Item to be assembled at organizational level.
AF	Item to be assembled at direct support maintenance level.
AD	Item to be assembled at depot Maintenance level.
XA	Item is not procured or stocked because the requirements for the item will result in the replacement of the next higher assembly.

Code	D e f i n i t i o n
XB	Item is not procured or stocked. If not available through salvage requisition.
XC	Installation drawing, diagram, instruction sheet, field service drawing, that is identified by manufacturer's part number.
XD	A support item that is not stocked. When required item will be procured through normal supply channels.

NOTE

Cannibalization or salvage, when authorized, maybe used as a source of supply for any items coded above, except those coded XA and aircraft support items as restricted by AR 700-42.

(2) Maintenance Code. Maintenance codes are assigned to indicate the levels of maintenance authorized to USE and REPAIR support items. The maintenance codes are entered in the third or fourth positions of the Uniform SMR Code format as follows:

(a) The maintenance code entered in the third position will indicate the lowest maintenance level authorized to remove, replace, and use the support item. The maintenance code entered in the third position will indicate one of the following levels of maintenance.

Code	Application / Explanation
O	Support item is removed, replaced, used at the organizational level.
F	Support item is removed, replaced, used at the direct support level.
D	Support items that are removed, replaced, used at depot, mobile depot, or specialized repair activity only.

(b) The maintenance code entered in the fourth position indicates whether the item is to be repaired and identifies the lowest maintenance level with the capability to perform complete repair (i.e., all authorized maintenance functions). This position will contain one of the following maintenance codes.

Code	Application / Explanation
O	The lowest maintenance level capable of complete repair of the support item is the organizational level.
F	The lowest maintenance level capable of complete repair of the support item is the direct support level.
D	The lowest maintenance level capable of complete repair of the support item is the depot level.

Code	Application / Explanation
L	Repair restricted to designated specialized repair activity.
Z	Nonrepairable. No repair is authorized
B	No repair is authorized. The item may be conditioned by adjusting, lubricating, etc., at the user level. No parts or special tools are procured for the maintenance of this item.

(3) Recoverability Code. Recoverability codes are assigned to support items to indicate the disposition action on unserviceable items. The recoverability code is entered in the fifth position of the Uniform SMR Code format as follows:

Recoverability Code	Definition
Z	Nonrepairable item. When unserviceable, condemn and dispose at the level indicated in position 3.
O	Repairable item. When uneconomically repairable, condemn and dispose at the organizational level.
F	Repairable item. When uneconomically repairable, condemn and dispose at the direct support level.
D	Repairable item. When beyond lower level repair capability, return to depot. Condemnation and disposal not authorized below depot level.
L	Repairable item. Repair, condemnation, and disposal not authorized below depot / specialized repair activity level.
A	Item requires special handling or condemnation procedures because of specific reasons (i.e., precious metal content, high dollar value, critical material or hazardous material). Refer to appropriate manuals / directives for specific instructions.

c. **FSCM (Column (3))**. The Federal Supply Code for Manufacturers (FSCM) is a 5-digit numeric code listed in SB 708-42 which is used to identify the manufacturer, distributor, or Government agency, etc. that supplies the item.

d. **PART NUMBER (Column (4))**. Indicates the primary number used by the manufacturer (individual, company, firm, corporation, or Government activity), which controls the design and characteristics of the item by means of its engineering drawings, specifications, standards and inspection requirements to identify an item or range of items.

NOTE

When a national stock number (NSN) item is requisitioned, the item received may have a different part number than the part being replaced.

e. **DESCRIPTION AND USABLE ON CODE (UOC) (Column5)**. Indicates the Federal item name and, if required, a minimum description to identify the item. Items that are included in kits and sets are listed below the name of the kit or set with the quantity of each item in the kit or set indicated in the quantity incorporated in the unit column. When the part to be used differs between serial numbers of the same model, the effective aerial numbers are shown as the last line of the description and the usable on code is utilized. In the Special Tools List, the initial base of issue (BOI) appears at the last line in the entry for each special tool, special TMDE, and other special support equipment. When density of equipments supported exceeds density spread indicated in the basis of issue, the total authorization is increased accordingly. The statement "END OF FIGURE" appears just below the last item description in Column 5 for a given figure in both Sections II and III.

f. **QTY (Column 6)**. Indicates the quantity of the item used in the breakout shown on the illustration figure, which is prepared for a functional group, sub-functional group, or an assembly. A "V" appearing in this column in lieu of a quantity indicates that no specific quantity is applicable, (e.g., shims, spacers, etc).

C-4. Explanation of Columns (Section IV).

a. **NATIONAL STOCK NUMBER (NSN) INDEX.**

(1) STOCK NUMBER Column. Lists the National Stock Number (NSN) in Federal Supply Class (FSC) Sequence.

NOTE

When ordering items by stock number, the complete NSN shall be used.

(2) FIG. Column. Indicates the number of the figure where the item is located/ identified.

(3) ITEM COLUMN. Item number identifies the item associated with the adjacent figure. The item may also be identified by the NSN.

b. **PART NUMBER INDEX.** Items in this index are listed by part number in ascending alpha-numeric sequence (vertical arrangement of letter and number combination which places the first letter of digit of each group in order A through Z, followed by the numbers O through 9 and each following letter or digit in like order).

(1) FSCM Column. The Federal Supply Code for Manufacturers (FSCM) is a 5-digit number code listed in SB 708-42 which is used to identify the manufacture, distributor, or Government agency, etc. that supplies the item.

(2) PART NUMBER Column. Indicates the primary number used by the manufacturer (individual, company, firm, corporation, or Government activity), which controls the design and characteristics of the item by means of its engineering drawings, specifications, standards and inspection requirements to identify an item or range of items.

(3) STOCK NUMBER Column. Indicates the National Stock Number assigned to the corresponding part number.

(4) FIG. Column. Indicates the number of the figure where the item is located/ identified in Sections II and III.

(5) ITEM Column. Item number identifies the item associated with the adjacent figure.

C-5. Special Information.

a. **Assembly Instructions.** Detailed assembly instruction for items source coded to be assembled are found in Chapters 2 and 3 of this manual. Assembly components are listed immediately following the item to be assembled.

b. **Assembly References.** When details of an assembly are shown on another text page, the description of that assembly is followed by a notation stating where these details can be located. Example: “161954-100, Fuel Control (See Fig. 6 for Breakdown)”. The parts that make up the Fuel Control will be found on the next text listing for Figure 6.

C-6. How to Locate Repair Parts.

a. **When National Stock Number or Part Number is Unknown**

(1) First. Using the table of contents, determine the functional group within which the item belongs. This is necessary since illustrations are repaired for functional groups, and listings are divided into the same groups.

(2) Second. Find the illustration covering the functional group to which the item belongs.

(3) Third. Identify the item on the illustration and note the item number,

(4) Fourth. Using the Repair Parts List, find the item number noted on the illustration,

(5) Fifth. Refer to the Part Number Index to determine National Stock Number (if assigned).

b. **When National Stock Number or Part Number is Known:**

(1) First. Using the Index of National Stock Numbers and Part Numbers, find the pertinent National stock number or part number. This index is in FSC sequence followed by a list of part number in alphanumeric sequence, cross-referenced to the illustration figure number and item number.

(2) **Second.** After finding the figure and item number, locate the figure and item number in the repair parts list.

C-7. Abbreviations.

Abbreviations	Explanation
BOI	Basis of Issue
NSN	National Stock Number
RPSTL	Repair Parts and Special Tools List

**THIS PAGE
INTENTIONALLY
LEFT BLANK**

Section II. REPAIR PARTS LIST

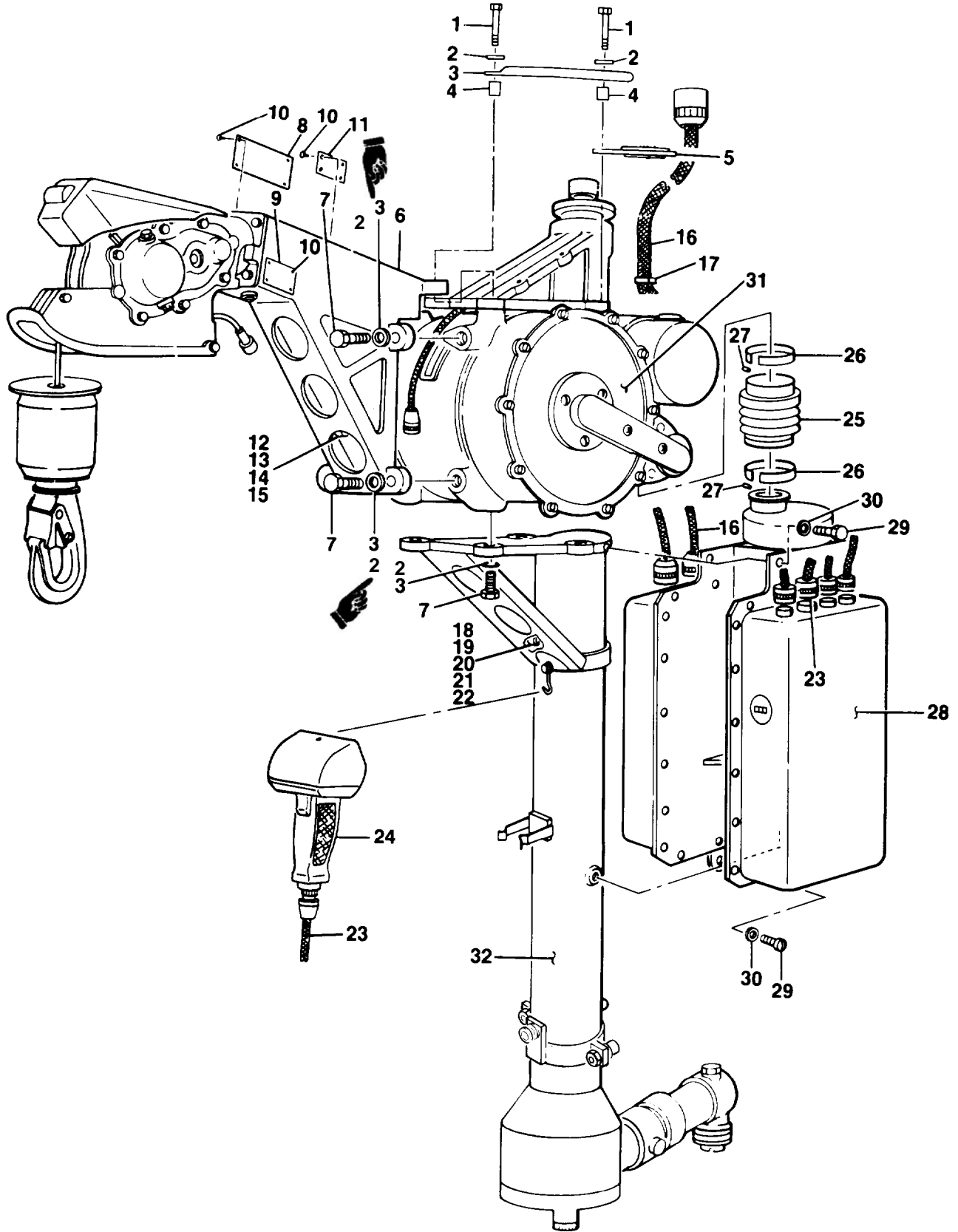


FIGURE C-1. RESCUE HOIST ASSY, HIGH PERFORMANCE

(1) ITEM NO.	(2) SMR CODE	(3) FSCM	(4) PART NUMBER	(5) DESCRIPTION AND USABLE ON CODE (UOC)	(6) QTY
				GROUP 00: RESCUE HOIST ASSEMBLY, HIGH PERFORMANCE	
				FIG. C-1. RESCUE HOIST ASSY, HIGH PERFORMANCE	
1	PAODD	82402	42305R1	RESCUE HOIST ASSY, HIGH PERFORMANCE	1
	XDODD	82402	42305R11	.CONTAINER, SHIPPING, REUSABLE	1
	PAOZZ	88044	AN176-24A	.BOLT	4
2	PAOZZ	96906	MS20002C6	.WASHER Item 2 as depicted on Page C-1 should not be required when installed on a AN176-24A bolt. TRW Aeronautical Systems Lucas Aerospace Depot Maintenance Manuals does not require any washers to be installed on the top side of the carrying handle. Recommend that no washers are installed on the top side of the carrying handle.	8
3	PBOZZ	82402	42305E42	.HANDLE, CARRYING	2
4	PAOZZ	82402	42305C41	.SPACER	4
5	PAOZZ	82402	42305D711	.BRACKET-UMBILICAL ASSY	1
6	PAODD	82402	42305R300	.BOOM HEAD ASSY (SEE FIG. C-3 FOR BREAKDOWN)	1
7	PAOZZ	96906	MS21250-06006	.BOLT	8
8	XDDZZ	82402	42305D30	.PLATE, IDENTIFICATION	1
9	PADZZ	82402	42305C229	.PLATE, CAUTION	2
10	PAOZZ	96906	MS21318-7	.SCREW	12
11	XDDZZ	82402	42305C12	.PLATE, IDENTIFICATION	1
12	PAOZZ	88044	AN742H4	.CLAMP.	1
13	PAOZZ	88044	MS35266-63	.SCREW	1
14	PAOZZ	96906	MS21083N3	.NUT	1
15	PAOZZ	88044	AN743-12	.BRACKET	1
16	PBOZZ	82402	42305E730	.CABLE, UMBILICAL	1
17	PAOZZ	82402	TA5000LH14HA	.CLAMP, UMBILICAL	1
18	PAOZZ	96906	MS21333-71	.CLAMP	1
19	PAOZZ	88044	MS35266-63	.SCREW	2
20	PAOZZ	88044	AN115807	.SCREW	2
21	PAOZZ	96906	MS21083N3	.NUT, SELFLOCK	1
22	PAOZZ	88044	AN743-12	.BRACKET	1
23	PBOZZ	82402	42305E710	.CABLE, CONTROL	1
24	PAOFF	82402	42305E720	.PENDANT ASSY, CONTROL (SEE FIG. C-2 FOR BREAKDOWN)	1
25	PAOZZ	82402	42277E194	.BOOT	1
26	PAOZZ	82402	502R	.BANDCLAMP ASSY	2
27	PAOZZ	82402	503R	.CLAMP	1
28	PAODD	82402	42305R700	.PANEL ASSY, CONTROL (SEE FIG. C-6 FOR BREAKDOWN)	1
29	PAOZZ	88044	AN175-4A	.BOLT	4
30	PAOZZ	88044	AN960-416	.WASHER	4
31	PAFDD	82402	42305R100	.WINCH ASSY (SEE FIG.C-18 FOR BREAKDOWN)	1
32	PBFDD	82402	42305R500	.SUPPORT ASSY, BOOM POSITION (SEE FIG. C-11 FOR BREAKDOWN)	1
	PAOOO	82402	42305-620	KIT, QUICK DISCONNECT AND STUD RING	REF
	PAOZZ	82402	42305E581	.CEILING ADAPTER	1

TM55-1680-320-23&P

(1) ITEM NO.	(2) SMR CODE	(3) FSCM	(4) PART NUMBER	(5) DESCRIPTION AND USABLE ON CODE (UOC)	(6) QTY
	XDOZZ	82402	42305E590	.STUD RING ASSY	1
	PAOZZ	82402	42305-613	.SAFETY CLIP AND LANYARD ASSY	1
	PAOZZ	82402	42305-614	.PLUG, STUD HOLE	1
	PAOZZ	96906	MS24665-359	.PIN, COTTER	1
END OF FIGURE					

**THIS PAGE
INTENTIONALLY
LEFT BLANK**

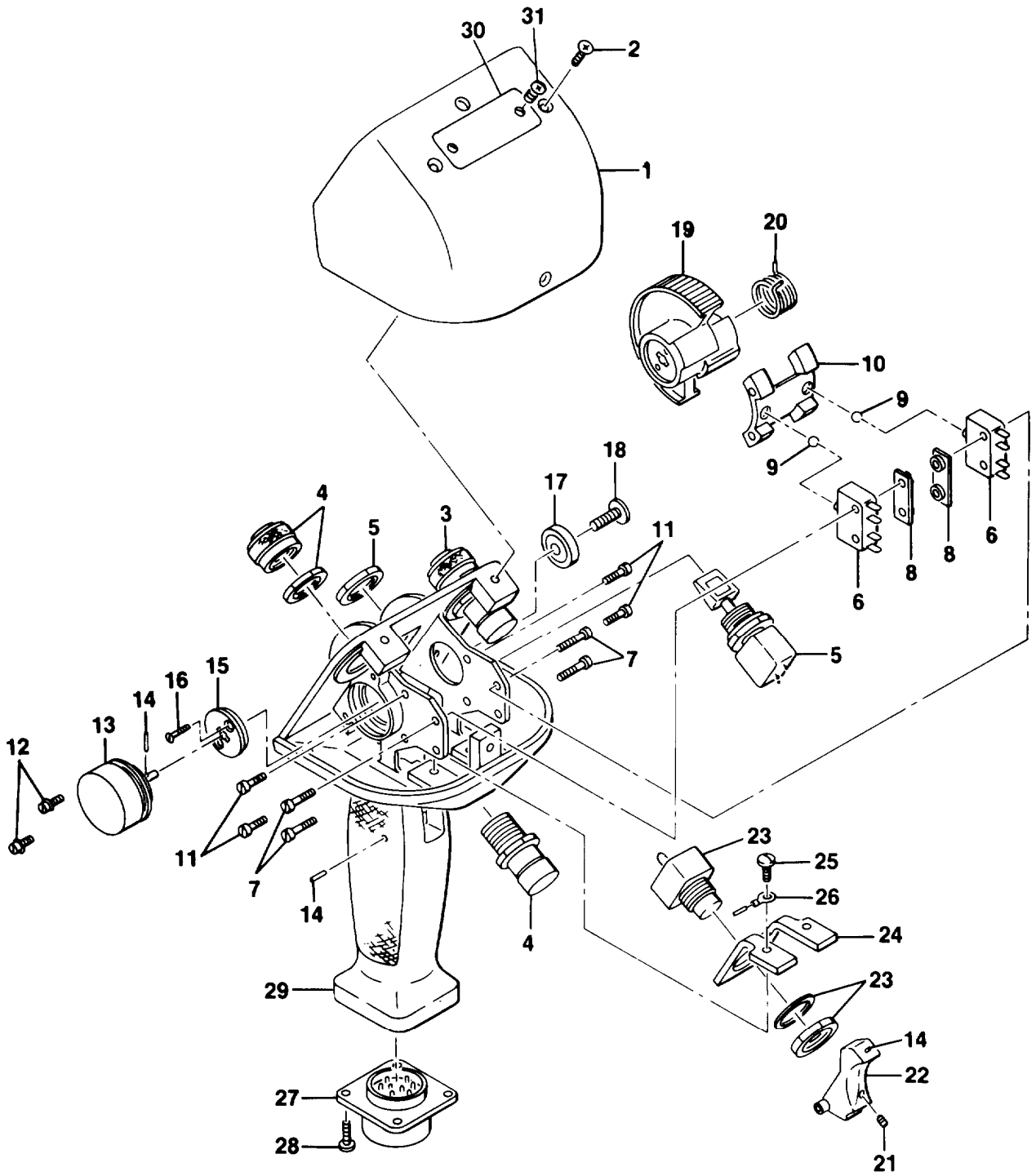


FIGURE C-2. PENDANT ASSY, CONTROL

(1) ITEM NO.	(2) SMR CODE	(3) FSCM	(4) PART NUMBER	(5) DESCRIPTION AND USABLE ON CODE (UOC)	(6) QTY
				GROUP 01: PENDANT ASSEMBLY, CONTROL	
				FIG. C-2. PENDANT ASSY, CONTROL	
	PAOFF	82402	42305E720	PENDANT ASSY, CONTROL (SEE FIG. C-1 FOR NHA)	1
1	XCFFF	82402	149145	.PENDANT, CONTROL.	1
2	PAFZZ	82402	149156	. . COVER	1
3	PAFZZ	96906	MS24693-B25	. . SCREW	3
4	PAFZZ	96906	MS25041-4	. . LIGHT,INDICATOR	1
5	PAFZZ	96906	MS25041-2	. . LIGHT,INDICATOR	1
6	PAFZZ	82402	80327	. . SWITCH, BOOM POSITION	1
7	PAFZZ	96906	MS27217-1	. . SWITCH (S1, S2)	2
8	PAFZZ	96906	MS35265-7	. . SCREW	4
9	PBFZZ	82402	149163	. . PLATE	2
10	PAFZZ	96906	MS19060-4812	. . BALL	2
11	PBFZZ	82402	149152	. . RETAINER,Ball	1
12	PAFZZ	96906	MS35265-4	. . SCREW	4
13	PAFZZ	00141	L3-20	. .CLEATS.	2
14	PAFZZ	02111	152-79-00	. . POTENTIOMETER	1
15	PAFZZ	96906	MS171434	. . PIN-SPRING	4
16	PBFZZ	82402	149155	. . BEARING	1
17	PAFZZ	96906	MS51959-4	. . S C R E W	2
18	PAFZZ	82402	149224	. . BEARING	1
19	PAFZZ	96906	MS51957-43	. . SCREW	1
20	PAFZZ	82402	149150	. . THUMBWHEEL	1
21	PAFZZ	82402	80326	. . SPRING.	1
22	PAFZZ	96906	MS51977-20	. . SETSCREW.	1
23	PBFZZ	00462	149148	. . TRIGGER	1
24	PAFZZ	96214	400859	. . SWITCH,INTERCOM	1
25	XAFZZ	82402	149154	. . BRACKET	1
26	PAFZZ	96906	MS51957-13	. . SCREW	2
27	PAFZZ	96906	MS35430-4	. . TERMINAL LUG	1
28	PBFZZ	96906	MS3472W14-19S	. . CONNECTOR	1
29	PAFZZ	96906	MS51957-14B	. . SCREW	4
30	XAFZZ	82402	149146	. . GRIP	1
31	XDDZZ	82402	42305C721	. . PLATE, IDENTIFICATION	1
	PAFZZ	96096	MS21318-7	. . SCREW	2
				END OF FIGURE	

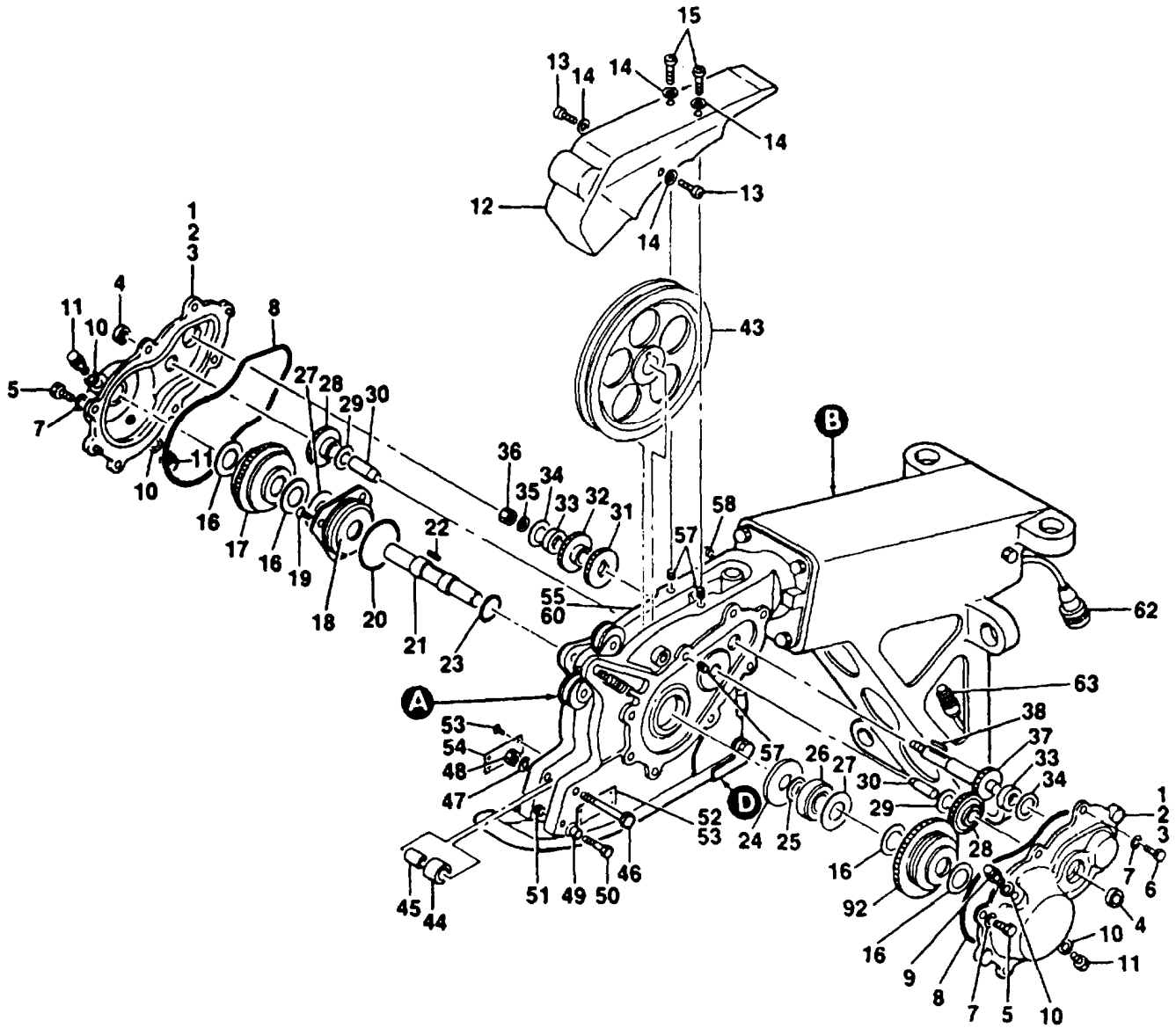


FIGURE C-3. BOOM HEAD ASSY (SHEET 1 OF 4)

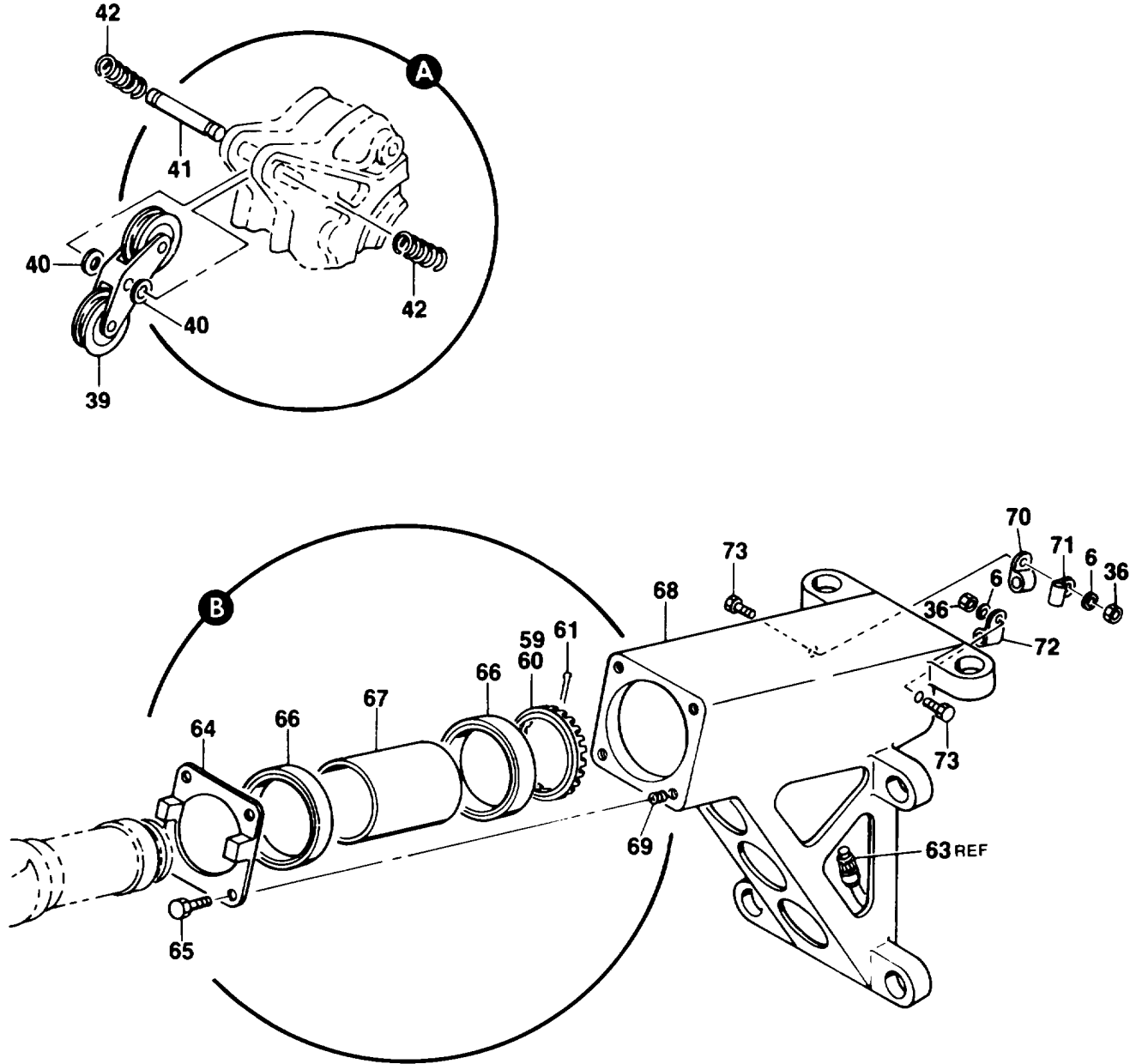


FIGURE C-3. BOOM HEAD ASSY (SHEET 2 OF 4)

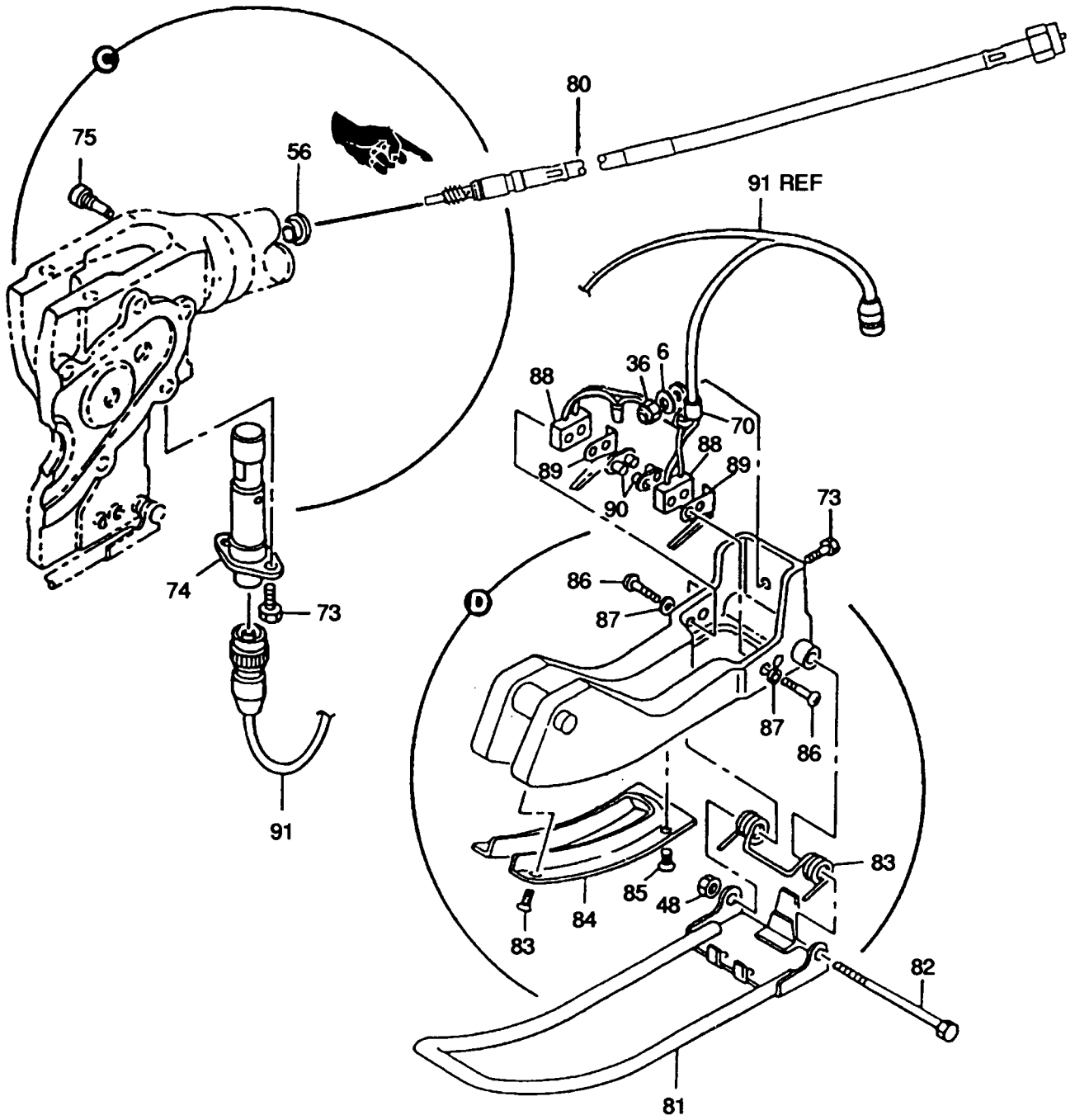


FIGURE C-3. BOOM HEAD ASSY (SHEET 3 OF 4)

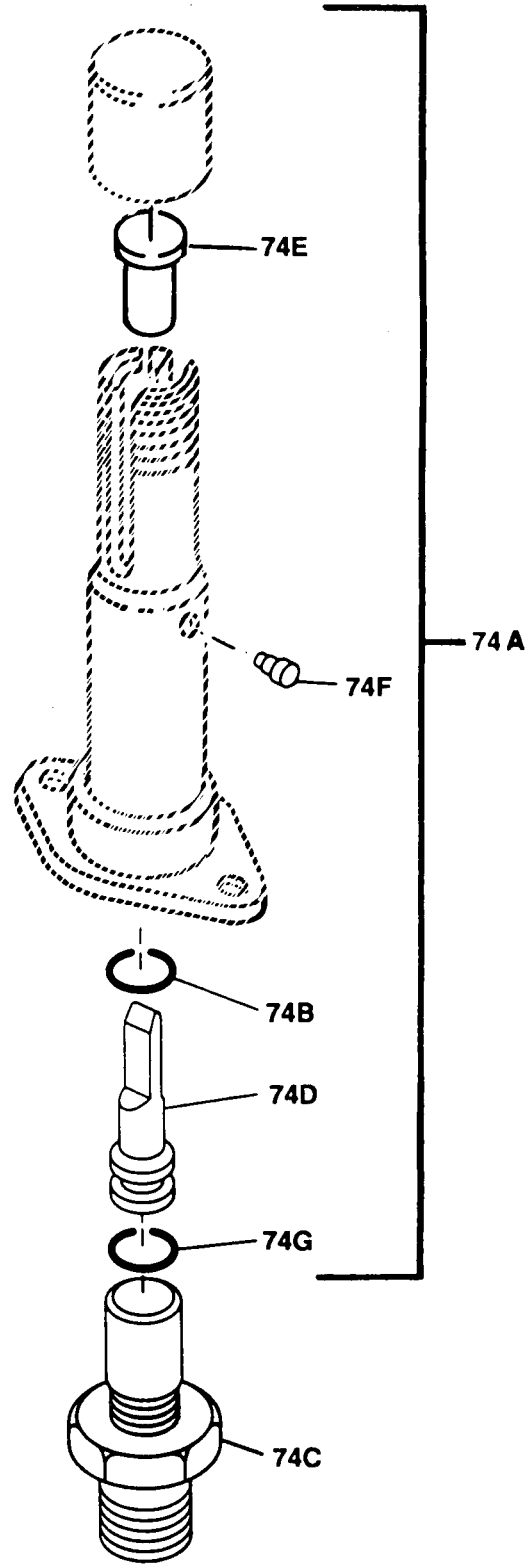


Figure C-3. Boom Head Assy (Sheet 4 of 4)

(1) ITEM NO.	(2) SMR CODE	(3) FSCM	(4) PART NUMBER	(5) DESCRIPTION AND USABLE ON CODE (UOC)	(6) QTY
GROUP 02: BOOM HEAD ASSEMBLY					
FIG.C-3. BOOM HEAD ASSY					
	PAODD	82402	42305R300	BOOM HEAD ASSY (SEE FIG. C-1 FOR NHA)	REF
1	XDOFF	82402	42277R311-5	COVER ASSY,SIDE	2
2	XAFZZ	82402	42277R311-1	COVER	1
3	PAFZZ	82402	42277C351	PIN	2
4	PAOZZ	70925	B-5602	PLUG,SIGHT	1
5	PAOZZ	88044	AN3C5A	BOLT	8
6	PAOZZ	88044	AN3CH5A	BOLT	4
7	PAOZZ	80205	NAS1252-10L	WASHER, FLAT	15
8	PAOZZ	96906	MS28775-156	PACKING, SIDE COVE	2
9	PAOZZ	82402	42305D372	BREATHER ASSY	1
10	PAOZZ	96906	MS28775-010	PACKING	4
11	PAOZZ	96906	MS9015-02	PLUG	3
12	PAOOO	82402	42277E339	COVER ASSY,PRESURE ROLLER	1
13	PAOZZ	96906	MS35207-263	SCREW	2
14	PAOZZ	96906	MS14151-2	WASHER, FLAT	4
15	PAOZZ	96906	MS35207-266	SCREW	2
16	PAFZZ	09455	LTD-0816	WASHER, THRUST	4
17	PAFFF	82402	42277D318	CLUTCH ASSY (SEE FIG. C-5 FOR BREAKDOWN)	1
18	PAFZZ	82402	42277D322	RETAINER ASSY	1
19	PAFZZ	96906	MS51960-65	SCREW	3
20	PAFZZ	81349	M83461/1-127	PACKING	1
21	PBFZZ	82402	42277D356	SHAFT,SLEEVE	1
22	PAFZZ	96906	MS20066-117	KEY, MACHINE	1
23	PAFZZ	96906	MS28775-013	PACKING	1
24	PAFZZ	82402	42277-360	SEAL ASSY	1
25	PAFZZ	82402	42277C326	SPACER,SHEAVE	1
26	PAFZZ	38443	102-KR	BEARING,BALL	1
27	PAFZZ	80402	49001C42	SHIM	V
28	PAFZZ	82402	42277D320	GEAR ASSY	2
29	PAFZZ	09445	LTD-0510	WASHER, THRUST	2
30	PAFZZ	96906	MS16555-53	PIN	2
31	PAFZZ	82402	42277E362	GEAR, WORM	1
32	PBFZZ	82402	42277D335	GEAR, SPUR	1
33	PBFZZ	21355	PAMS1K7FS60160	BEARING, BALL	2
34	PAFZZ	82402	49001C6	SHIM	2
35	PAFZZ	80205	NAS620-10L	WASHER	1
36	PAFZZ	96906	MS21045-3	NUT, SELF LOCK	4
37	PAFZZ	82402	42277D359	GEAR SHAFT, SPUR	1
38	PAFZZ	82402	42277C346	KEY, MACHNE	1
39	PAOZZ	82402	42277D330	ROLLER ASSY, PRESSURE	1
40	PAOZZ	80205	NAS620A416L	WASHER, FLAT	2
41	PBOZZ	82402	42277C341	SHAFT, ROLLER	1

(1) ITEM NO.	(2) SMR CODE	(3) FSCM	(4) PART NUMBER	(5) DESCRIPTION AND USABLE ON CODE (UOC)	(6) QTY
42	PAOZZ	83553	E0360-055-1120M	SPRING	2
43	PBFZZ	82402	42277E327	SHEAVE ASSY	1
44	PAOZZ	82402	42277C352	GUIDE,CABLE ROLLER	1
45	PAOZZ	82402	42277C342	SPACER,CABLE GUIDE	1
46	PAOZZ	88044	AN3-16A	BOLT	1
47	PAOZZ	88044	AN960PD10L	WASHER,FLAT	4
48	PAOZZ	96906	MS21045-3	NUT,SELF-LOCK	2
49	PAOZZ	82402	42277C366	STOP,ACTUATOR	1
50	PAOZZ	96906	MS16998-30	SCREW	1
51	PAOZZ	96906	MS21042-3	NUT,SELF-LOCK	1
52	XDDZZ	80402	42305C350	PLATE,IDENTIFICATION	1
53	PAOZZ	96906	MS21318-7	SCREW	8
54	XDDZZ	82402	42277C221	PLATE,LUBRICATION	1
55	XADDD	82402	42277R310-5	HOUSING ASSY,MAIN	1
56	PADZZ	70417	FF303-4	BEARING	1
57	PADZZ	96906	MS51830-201L	INSERT	25
58	PADZZ	96906	MS51830-202	INSERT	1
59	PADZZ	82402	42277C370	NUT,SPANNER	1
60	XADDD	82402	42277R310-1	HOUSING	1
61	PADZZ	96906	MS24665-281	PIN,COTTER	1
62	PAFZZ	96906	MS3126F10-6P	CONNECTOR,ELECTRICAL	1
63	PBOOO	82402	42277D369	HARNES ASSY	1
64	PADZZ	82402	42234D220	RETAINER,BEARING	1
65	PADZZ	88044	AN4CH4A	BOLT	4
66	PADZZ	38443	B545ZZ	BEARING	2
67	PBDZZ	82402	42277D354	SPACER	1
68	XAODD	82402	42277R312-5	BOOM ASSY	1
69	PADZZ	80205	NAS1394C4L	INSERT	4
70	PAFZZ	88044	AN742H4	CLAMP	3
71	PAFZZ	96906	MS21333-69	CLAMP	1
72	PAFZZ	96906	MS21333-71	CLAMP	1
73	PAFZZ	88044	AN3C4A	BOLT	5
74	PBFZZ	82402	42277E336	CABLE CUTTER	1
74A	PCOZZ	82402	42277E182	REFIRE KIT	1
74B	XAOZZ	82402	MS28775-009	PACKING	1
74C	XAOZZ	82402	42277-231	CARTRIDGE	1
74D	XAOZZ	82402	42277-232-1	CUTTER	1
74E	XAOZZ	82402	42277-232-2	ANVIL	1
74F	XAOZZ	82402	42277-232-3	PIN,SHEAR	1
74G	XAOZZ	82402	MS28778-4	PACKING	1
75	PBOOO	82402	42277C344	SCREW,RETAINER	1
76			DELETED		
77			DELETED		
78			DELETED		
79			DELETED		
80	PAFZZ	82402	42277E328	DRIVESHAFT,FLEXIBLE	1
81	PAOZZ	82402	42277E332	ACTATOR ASSY	1
82	PAOZZ	80205	NAS1103-44	BOLT	1
83	PAOZZ	82402	42277E358	SPRING	1
84	PAOZZ	82402	42277E368	GUIDE,CABLE	1
85	PAOZZ	96906	MS24694C49	SCREW	4
86	PAOZZ	96906	MS51957-9	SCREW	4
87	PAOZZ	80205	NAS620A2	WASHER,FLAT	4
88	PAFZZ	82402	42277D343	MICROSWITCH ASSY	1

TM 55-1680-320-23&P

(1) ITEM NO.	(2) SMR CODE	(3) FSCM	(4) PART NUMBER	(5) DESCRIPTION AND USABLE ON CODE (UOC)	(6) QTY
89	PAOZZ	91929	JE12	.ACTUATOR, LEAF	2
90	PAFZZ	82402	4067C193	.NUTPLATE ASSY	2
91	PBFFF	82402	42277D353	.HARNESS ASSY, CABLE CUTTER	1
92	PAFFF	82402	42277D313	.BRAKE ASSY (SEE FIG. C-4 FOR BREAKDOWN) END OF FIGURE	1

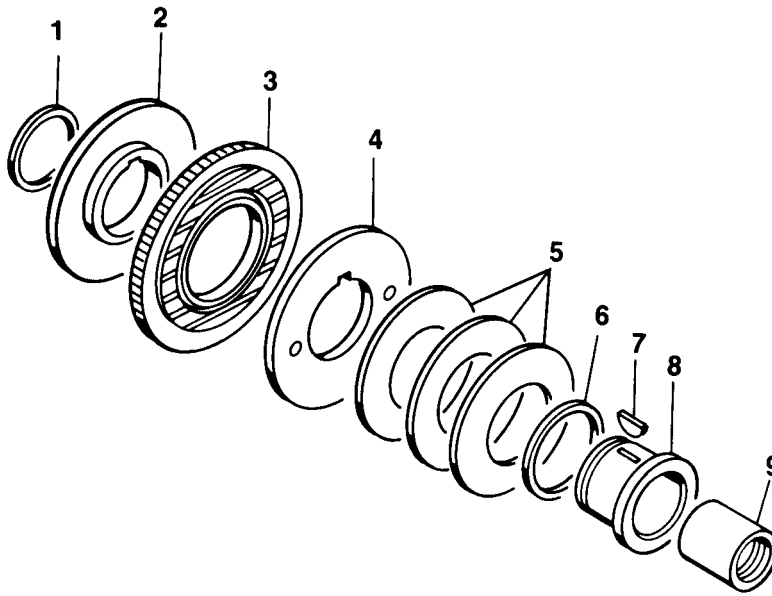


FIGURE C-4. BRAKE ASSEMBLY

(1) ITEM NO.	(2) SMR CODE	(3) FSCM	(4) PART NUMBER	(5) DESCRIPTION AND USABLE ON CODE (UOC)	(6) QTY
				GROUP 0201: BRAKE ASSEMBLY	
				FIG. C-4. BRAKE ASSY	
				BRAKE ASSY (SEE FIG. C-3 FOR NHA)	REF
1	PAFFF	82402	42277D313	. RING, RETAINING	1
2	PAFZZ	96906	MS16626-1100	. PLATE, BACKING	1
3	PAFZZ	82402	42277C314	. DISC ASSY	1
4	PBFZZ	82402	42277D347	. PLATE, PRESSURE	1
5	PAFZZ	82402	42277C315	. SPRING	3
6	PAFZZ	82402	42277C349	. SHIM	1
7	PAFZZ	82402	49002C39	. KEY	1
8	PAFZZ	96906	MS35756-3	. HUB	1
9	PBFZZ	82402	42277D317	. ROLLER, CLUTCH	1
				RCB081214FS	
				END OF FIGURE	

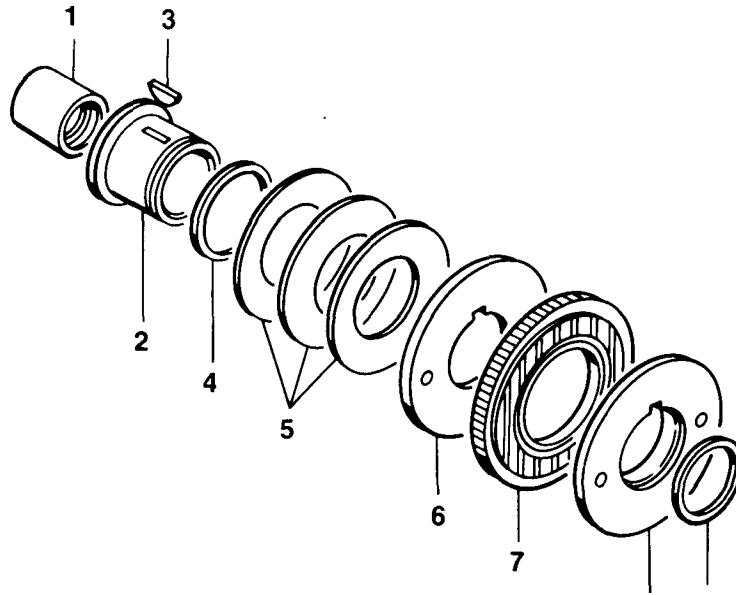


FIGURE C-5. CLUTCH ASSEMBLY

(1) ITEM NO.	(2) SMR CODE	(3) FSCM	(4) PART NUMBER	(5) DESCRIPTION AND USABLE ON CODE (UOC)	(6) QTY
				GROUP 0202: CLUTCH ASSEMBLY	
				FIG. C-5. CLUTCH ASSY	
1	PAFFF	82402	42277D318	CLUTCH ASSY (SEE FIG. C-3 FOR NHA)	REF
2	PAFZZ	60380	RCB081214FS	. ROLLER, CLUTCH	1
3	PBFZZ	82402	42277D317	. HUB	1
4	PAFZZ	96906	MS35756-3	. KEY	1
5	PAFZZ	82402	49002C39	. SHIM	1
6	PAFZZ	82402	42277C349	. SPRING	3
7	PAFZZ	82402	42277C315	. PLATE, PRESSURE	1
8	PAFZZ	82402	42277D348	. DISK ASSY	1
9	PAFZZ	82402	42277C314	. PLATE, BACKING	1
	PAFZZ	96906	MS16626-1100	. RING, RETAINING	1
				END OF FIGURE	

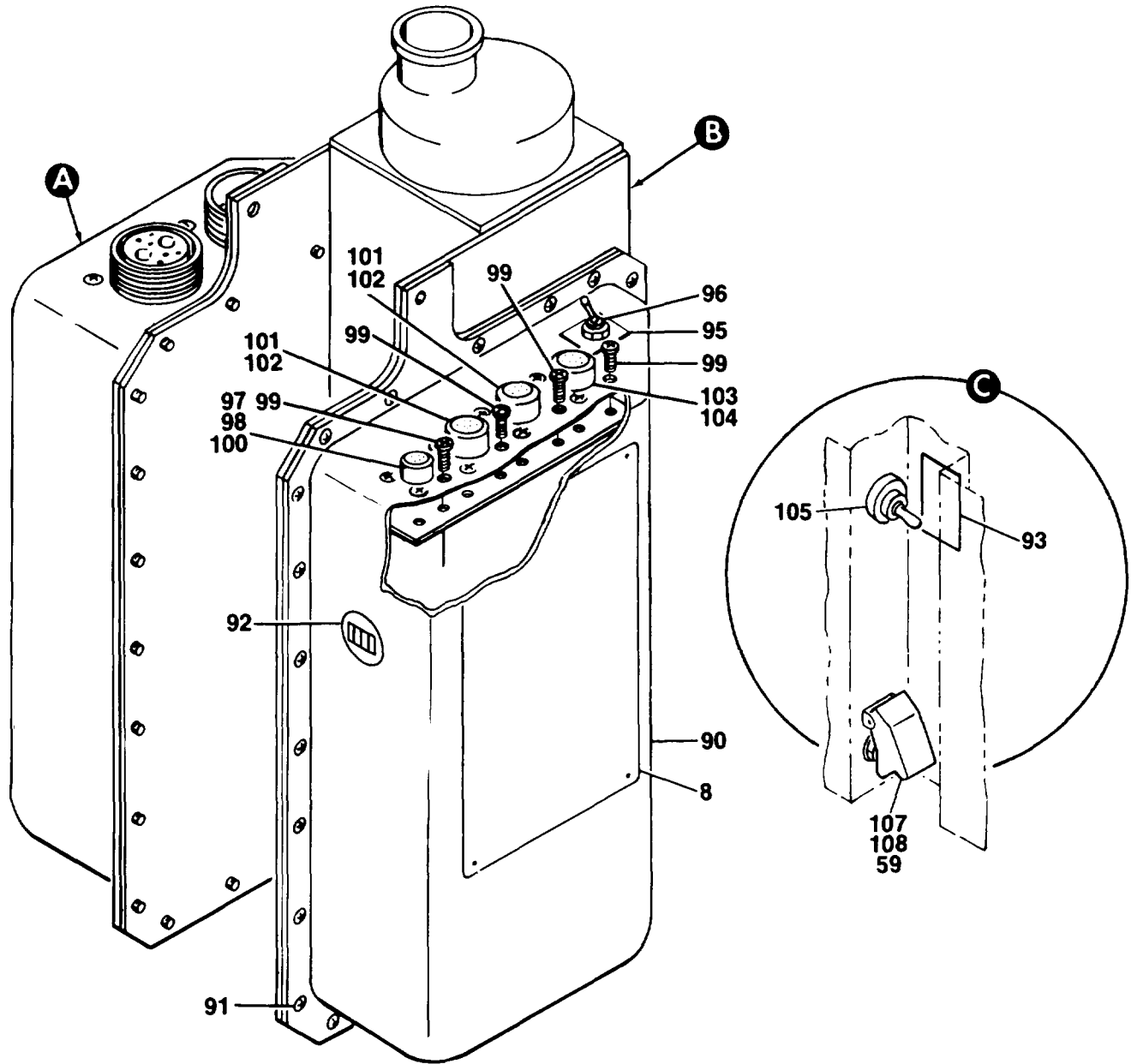


FIGURE C-6. PANEL ASSY, CONTROL (SHEET 1 OF 3)

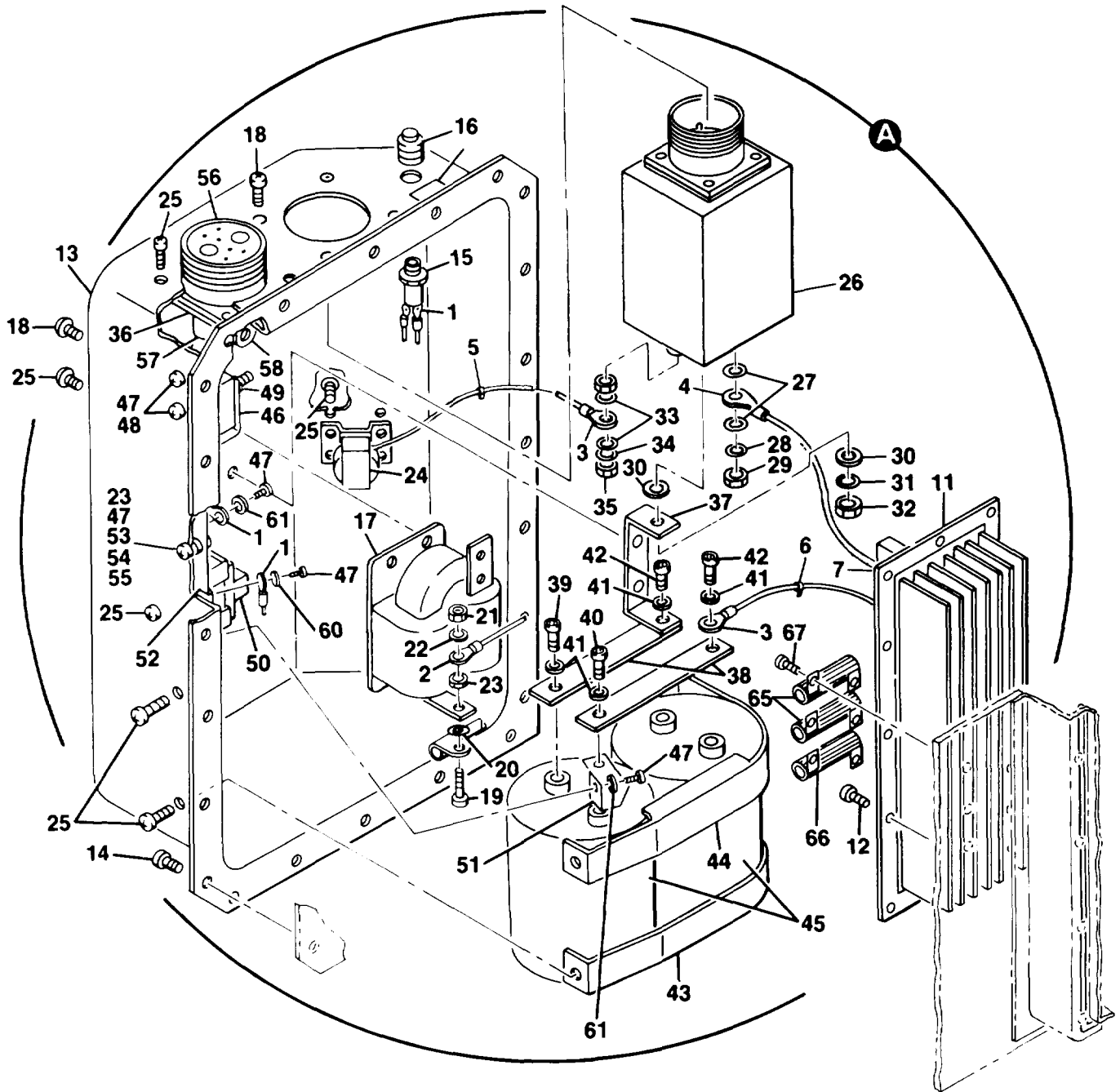


FIGURE C-6 PANEL ASSY, CONTROL (SHEET 2 OF 3)

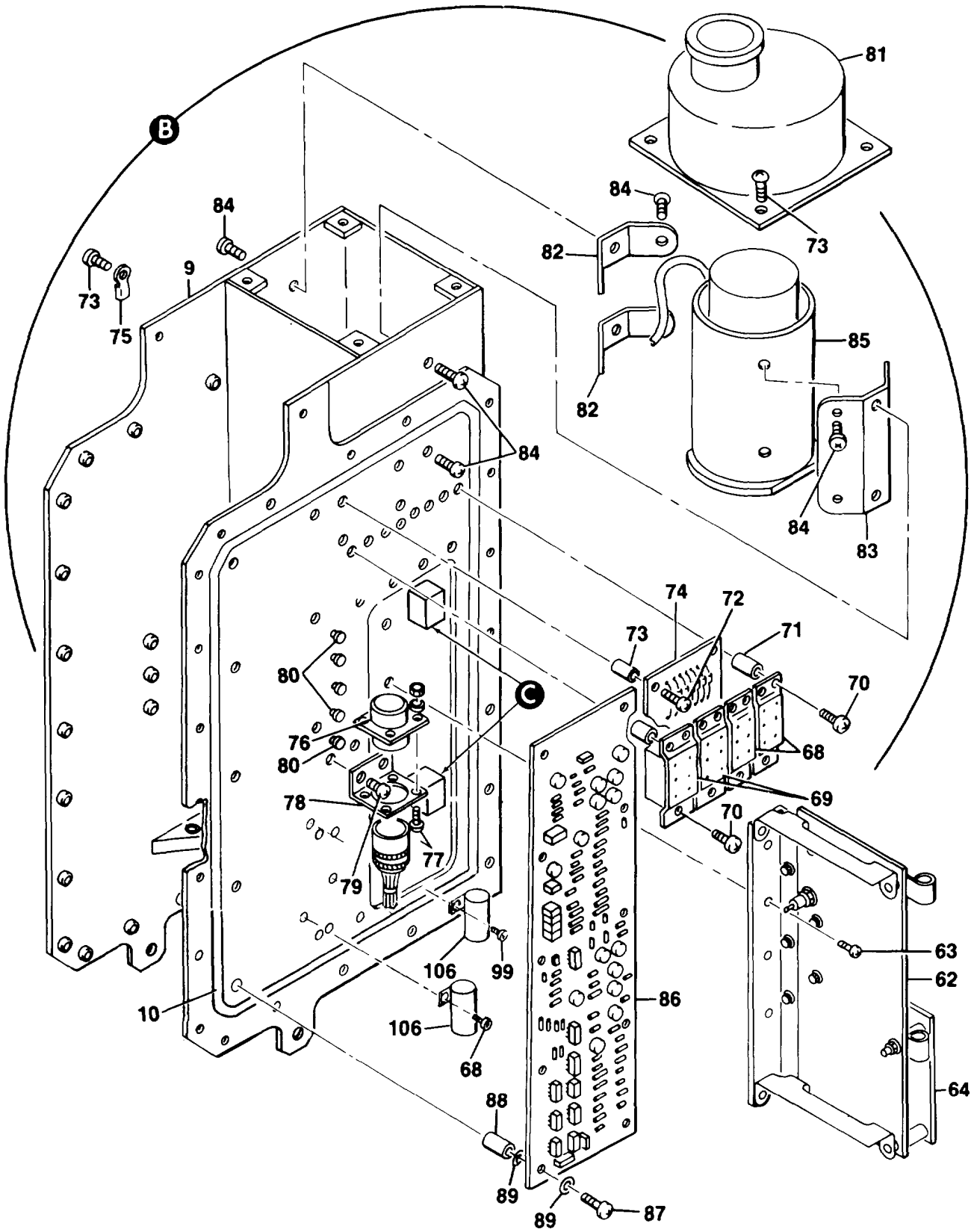


FIGURE C-6. PANEL ASSY, CONTROL (SHEET 3 OF 3)

TM 55-1680-320-23&P

(1) ITEM NO.	(2) SMR CODE	(3) FSCM	(4) PART NUMBER	(5) DESCRIPTION AND USABLE ON CODE (UOC)	(6) QTY
				GROUP 03: CONTROL PANEL ASSEMBLY	
				FIG. C-6. PANEL ASSY, CONTROL	
	PAODD	82402	42305R700	PANEL ASSY, CONTROL (SEE FIG. C-1 FOR NHA)	REF
	XCDDD	82402	149111	.CONTROL BOX ASSY	1
	ADDDD	82402	149097	. . WIRE ASSY	1
1	PADZZ	96906	MS25036-101	. . . TERMINAL LUG	22
2	PADZZ	96906	MS25036-149	. . . TERMINAL LUG	4
3	PADZZ	96906	MS25036-103	. . . TERMINAL LUG	13
4	PADZZ	96906	MS25036-108	. . . TERMINAL LUG	2
5	PADZZ	96906	MS3367-4-9	. . . STRAP, TIEDOWN	50
6	PADZZ	96906	MS3367-5-9	. . . STRAP, TIEDOWN	4
7	PADZZ	04713	MR508	. . . DIODE	2
8	PADZZ	82402	42305E724	. . PLATE, SCHEMATIC	1
9	XADZZ	82402	149119	. . CHASSIS, HOIST	1
10	PADZZ	12881	01-0504-1891	. . GASKET, EMI	V
11	PBDDD	82402	19221-3	. . HEATSINK ASSY, TRANSISTOR (SEE FIG. C-7 FOR BREAKDOWN)	1
12	PAFZZ	96906	MS21090-0414	. . SCREW	14
13	PBFDD	82402	19215-3	. . COVER ASSY	1
14	PADZZ	96906	MS21090-06001	. . . SCREW	25
15	PADZZ	96906	MS25237-327	. . . LAMP	1
16	PAOZZ	96906	MS25041-10	. . . LIGHT, INDICATOR (BLUE)	1
17	PADZZ	82402	149131	. . . INDUCTOR ASSY (L2)	1
18	PADZZ	96906	MS21096-08001	. . . SCREW	8
19	PADZZ	96906	MS16697-33	. . . SCREW	2
20	PADZZ	88044	AN960-8L	. . . WASHER	2
21	PADZZ	96906	MS35649-286	. . . NUT	2
22	PADZZ	96906	MS35338-99	. . . WASHER, LOCK	2
23	PADZZ	96906	MS21042L08	. . . NUT, SELF-LOCK	3
24	PBDZZ	82402	149540	. . . INDUCTOR ASSY (LI)	1
25	PADZZ	96906	MS21096-06001	. . . SCREW	15
26	PBDZZ	82402	149304-1	. . . FILTER ASSY, EMI	1
27	PADZZ	88044	AN960-516L	. . . WASHER	2
28	PADZZ	96906	MS35338-46	. . . WASHER, LOCK	1
29	PADZZ	96906	MS21083B5	. . . NUT	1
30	PADZZ	88044	AN960-616L	. . . WASHER	2
31	PADZZ	96906	MS35338-45	. . . WASHER, LOCK	1
32	PADZZ	96906	MS21083B6	. . . NUT	1
33	PADZZ	88044	AN960-10L	. . . WASHER	2
34	PADZZ	96906	MS35338-43	. . . WASHER, LOCK	1
35	PADZZ	96906	MS21083B3	. . . NUT	1
36	PADZZ	53217	42-81496	. . . GASKET, EMI	2
37	XDDZZ	82402	19210-1	. . . BUS BAR ASSY	1
38	XDDZZ	82402	19208	. . . BUS BAR, CAPACITOR	2

TM 55-1680-320-23&P

(1) ITEM NO.	(2) SMR CODE	(3) FSCM	(4) PART NUMBER	(5) DESCRIPTION AND USABLE ON CODE (UOC)	(6) QTY
39	PADZZ	96906	MS21295-16	... SCREW,ALLEN	1
40	PADZZ	96906	MS21295-22	... SCREW,ALLEN	1
41	PADZZ	96906	MS35338-100	... WASHER, LOCK	4
42	PADZZ	96906	MS21295-36	... SCREW,ALLEN	2
43	PADZZ	82402	19240-2	... BRACKET	1
44	PADZZ	82402	19240-1	... BRACKET	1
45	PADZZ	09213	3120GE243UO 50APA1	... CAPACITOR	2
46	XDDZZ	82402	149128	... SHUNT	1
47	PADZZ	96906	MS35206-246	... SCREW	7
48	PADZZ	96906	MS35649-282	... NUT	2
49	PADZZ	88044	AN960-416L	... WASHER	1
50	PADZZ	14304	755017A4021	... RELAY	1
51	PBDZZ	82402	19261	... BUS BAR, RELAY	1
52	PBDZZ	82402	19262	... BUS BAR, SHUNT	1
53	PADZZ	88044	AN960-8L	... WASHER	1
54	PADZZ	83330	2665	... WASHER, SHOULDER	1
55	PADZZ	51506	136-093N1	... WASHER, NYLON	2
56	XDDZZ	82402	19257	... RECEPTACLE ASSY	1
57	PADZZ	96960	MS20659-111	... TERMINAL LUG	1
58	PADZZ	96906	MS20659-144	... TERMINAL LUG	1
59	PADZZ	15605	32-341	... BUSHING	1
60	PADZZ	96906	MS35338-99	... WASHER,LOCK	4
61	PADZZ	96906	MS35338-98	... WASHER,LOCK	2
62	PBDDD	82402	19225-3	.. HEATSINK ASSY, POWER SUPPLY .. (SEE FIG. C-8 FOR BREAKDOWN)	1
63	PADZZ	96906	MS21096-06003	.. SCREW	6
64	PADZZ	82402	149470	.. BOARD ASSY, VOLTAGE CONTROL	1
65	PADZZ	81349	RER75G12R1R	.. RESISTOR (301, R302)	2
66	PADZZ	81349	RER75F4R02R	.. RESISTOR (R304)	1
67	PADZZ	96906	MS21090-0414	.. SCREW, SELF-LOCK	10
68	PBDZZ	35344	KD-D2A	.. RELAY, BOOM MOTOR	2
69	PBDZZ	96906	MS27400-9	.. RELAY, FIELD	2
70	PADZZ	96906	8217-SO632-3B	.. SCREW	12
71	PBDZZ	83330	8505	.. SPACER	12
72	PAFZZ	96906	MS21096-06001	.. SCREW	11
73	PADZZ	06540	8217-SO632-3B	.. SPACER	4
74	PAFZZ	82402	19255-1	.. BOARD ASSY, DIODE	1
75	PADZZ	96906	MS20659-130	.. TERMINAL LUG	1
76	PBDZZ	96906	MS3470W18-32P	.. RECEPTACLE	1
77	PADZZ	96906	MS21096-04001	.. SCREW	4
78	PBDZZ	82402	19234	.. BRACKET, CONNECTOR MOUNTING ..	1
79	PADZZ	96906	MS21096-06002	.. SCREW	2
80	PADZZ	81349	SE096E02	.. TERMINAL	5
81	XAFZZ	82402	19230	.. PLENUM, FAN ASSY	1
82	PBFZZ	82402	19236-1	.. BRACKET ASSY, FAN	2
83	PAFZZ	82402	19236-3	.. BRACKET ASSY, FAN	1

(1) Item No.	(2) SMR Code	(3) FSCM	(4) Part Number	Description And Usable On Code (UOC)	(6) Qty.
84	PAFZZ	96906	MS21096-08001	..Screw	12
85	PAFDD	82402	FV3-4	..Blower Assy, Fan (See Fig. C-10 For Breakdown)	1
86	PADDD	82402	19246	..PCB Assy, Logic (See Fig. C-9 For Breakdown)	1
87	PADZZ	96906	MS21096-06003	..Screw	10
88	PADZZ	06540	8217-S0632-3B	..Spacer	10
89	PADZZ	51506	140-015-N-1	..Washer	20
90	XDDZZ	82402	149090	..Cover, Assy, Logic Side	1
91	PAOZZ	96906	MS21090-0623	..Screw, Self-Lock	24
92	PADZZ	82227	KT1972240H0	..Meter, Elapsed Time	1
93	PBDZZ	82402	149161	..Decal, Switch	1
94	PBDZZ	82402	149192	.. Decal, Hoist Power	1
95	XDDZZ	82402	42277C704	..Plate, Identification	1
96	PADZZ	96906	MS24660-23D	.. Switch	1
97	PADZZ	82402	149093	..Nutplate Assy	1
98	PBDZZ	96906	MS3470W10-6S	..Receptacle	1
99	PADZZ	96906	MS21090-0414	..Screw	16
100	PADZZ	53127	42-81652	..Gasket (EMI)	1
101	PBDZZ	96906	MS3472W14-12S	..Receptacle	1
102	PADZZ	53127	42-81656	..Gasket (EMI)	2
103	PADZZ	53127	42-81654	..Gasket (EMI)	1
104	PBDZZ	96906	MS3470W12-8S	..Receptacle	1
105	PADZZ	96906	MS35058-22	.. Switch	1
106	PADZZ	81349	RER70F25ROR	..Resistor	2
107	PADZZ	96906	MS25306-222	..Switch	1
108	PADZZ	82402	19241	..Guard, Switch	1
END OF FIGURE					

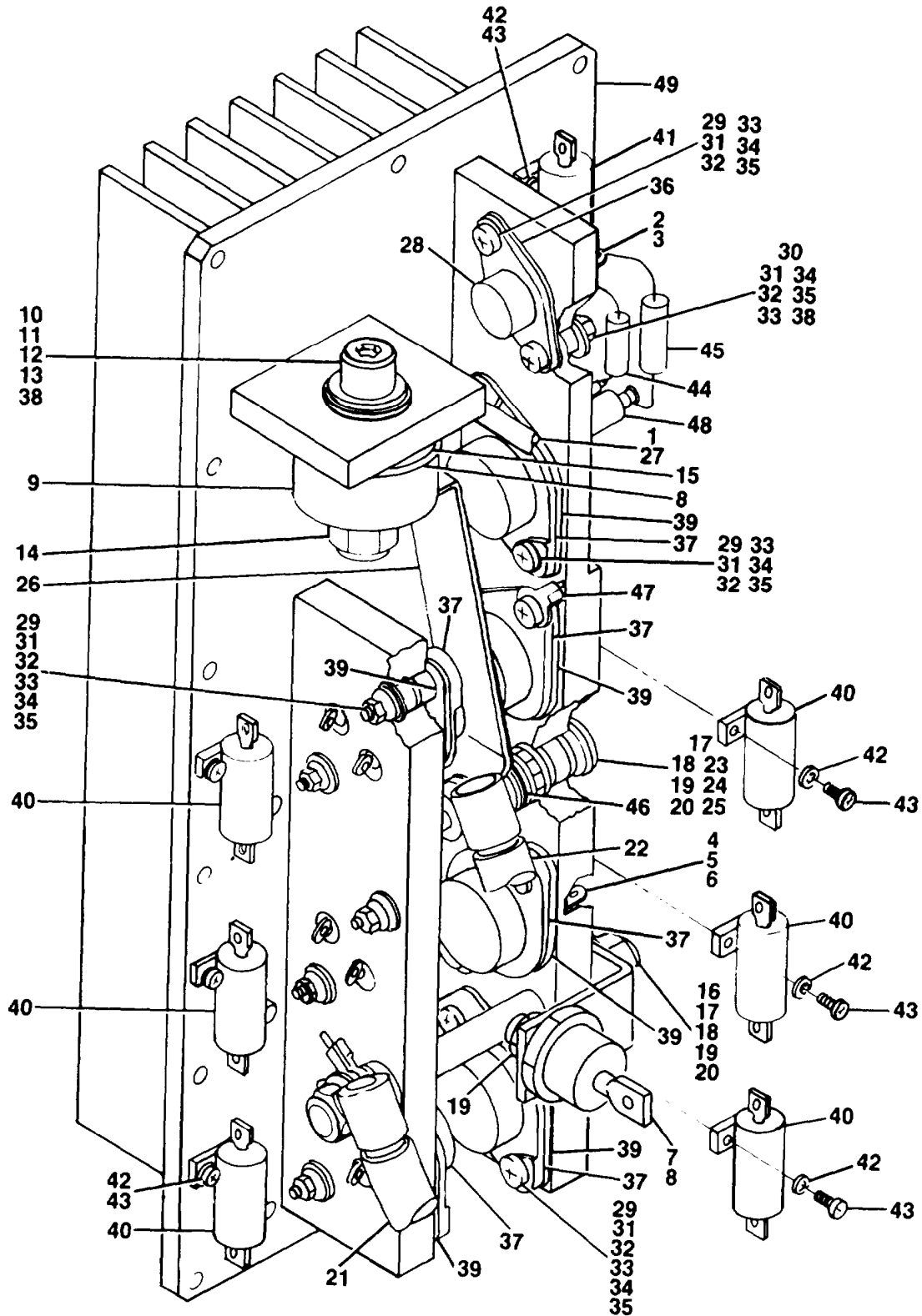


FIGURE C-7. HEATSANT ASSY, TRANSISTOR

TM 55-1680-320-23 & P

(1) ITEM NO.	(1) ITEM NO.	(3) FSCM	(4) PART NUMBER	DESCRIPTION AND USABLE ON CODE (UOC)	(6) QTY
				GROUP 03: CONTROL PANEL ASSEMBLY	
				FIG. C-7. HEATSINK ASSY, TRANSISTOR	
	PBDDD	82402	19221-3	HEATSINK ASSY (SEE FIG. C-6 FOR NHA)	REF
1	PBDZZ	82402	19233	.LUG, TERMINAL, DIODE	1
2	XDDDD	82402	9164	.HEAT SINK ASSY, DRIVER	1
3	PADZZ	05618	50334	.TERMINAL, UNINSULATED	2
4	PADZZ	06540	9226N140	.SPACER, NYLON	14
5	PADZZ	96906	MS20659-138	.TERMINAL, UNINSULATED	7
6	PADZZ	00779	34103	.TERMINAL, UNINSULATED	7
7	PADZZ	82402	149126	.DIODE, BUS BAR	1
8	PADZZ	81349	JANTX2N3911R	.DIODE	1
9	PADZZ	50891	SCSFIR	.DIODE	1
10	PADZZ	08289	TW-325-425-115N	.SPACER	2
11	PADZZ	86928	5605-44	.WASHER	1
12	PADZZ	88044	AN960-516L	.WASHER, FLAT	1
13	PADZZ	16941	LF15D058S13	.SCREW	1
14	PADZZ	72962	21NE058	NUT.	1
15	PADZZ	08289	DBW1062-330-062	.WASHER	1
16	PADZZ	82402	19214	.STUD, COPPER	1
17	PADZZ	96906	MS25082B4	NUT.	4
18	PADZZ	88044	AN960B416	.WASHER, FLAT	5
19	PADZZ	96906	MS21042L4	.NUT, SELF-LOCK	4
20	PADZZ	96906	MS35338-101	.WASHER, LOCK	2
21	ADDZZ	82402	19258-1	.CABLE ASSY	1
22	ADDZZ	82402	19258-3	.CABLE ASSY	1
23	PADZZ	96906	MS35215-75	.SCREW	1
24	PADZZ	86928	5605-40	.WASHER	2
25	PADZZ	08289	TW260-370-100TS	.SPACER	2
26	PADZZ	82402	19263	.BAR,BUS,HEATSINK	1
27	ADDZZ	82402	19258-7	.CABLE ASSY	1
28	PADZZ	04713	2N6049	.TRANSISTOR	1
29	PADZZ	96906	MS16997-22	.SCREW	15
30	PADZZ	96906	MS16997-21	.SCREW	1
31	PADZZ	96906	MS35338-98	.WASHER,LOCK	16
32	PADZZ	08289	TW-147-236-094N	.SPACER	16
33	PADZZ	86928	5605-28	.WASHER	16
34	PADZZ	88044	AN960-6	.WASHER	16
35	PADZZ	96906	MS21042L06	.NUT,SELF-LOCK	16
36	PADZZ	08289	TA2402A	.INSULATOR	1
37	PADZZ	81349	JANTX2N5686	.TRANSISTOR	7
38	PADZZ	96906	MS25036-101	.TERMINAL,LUG	1
39	PADZZ	13103	4003	.INSULATOR	7
40	PADZZ	81349	RER65FR100R	.RESISTOR	6
41	PADZZ	81349	RER65F1R00R	.RESISTOR	1
42	PADZZ	80205	NAS620-2	.WASHER	14

TM 55-1680-320-23&P

(1) ITEM NO.	(2) SMR CODE	(3) FSCM	(4) PART NUMBER	(5) DESCRIPTION AND USABLE ON CODE (UOC)	(6) QTY
43	PADZZ	96906	MS35206-203	. SCREW	14
44	PADZZ	81349	RCR32G220JS	.RESISTOR	1
45	PADZZ	81349	RCR32G271JS	.RESISTOR	1
46	PADZZ	96906	MS25036-154	.LUG, TREMINAL	15
47	PADZZ	96906	MS25036-106	.LUG,TREMINAL.	7
48	PADZZ	81349	SE096E02	.TERMINAL, INSULATED.	1
49	PADZZ	83330	9164	.SPACER,NYLON.	2
END OF FIGURE					

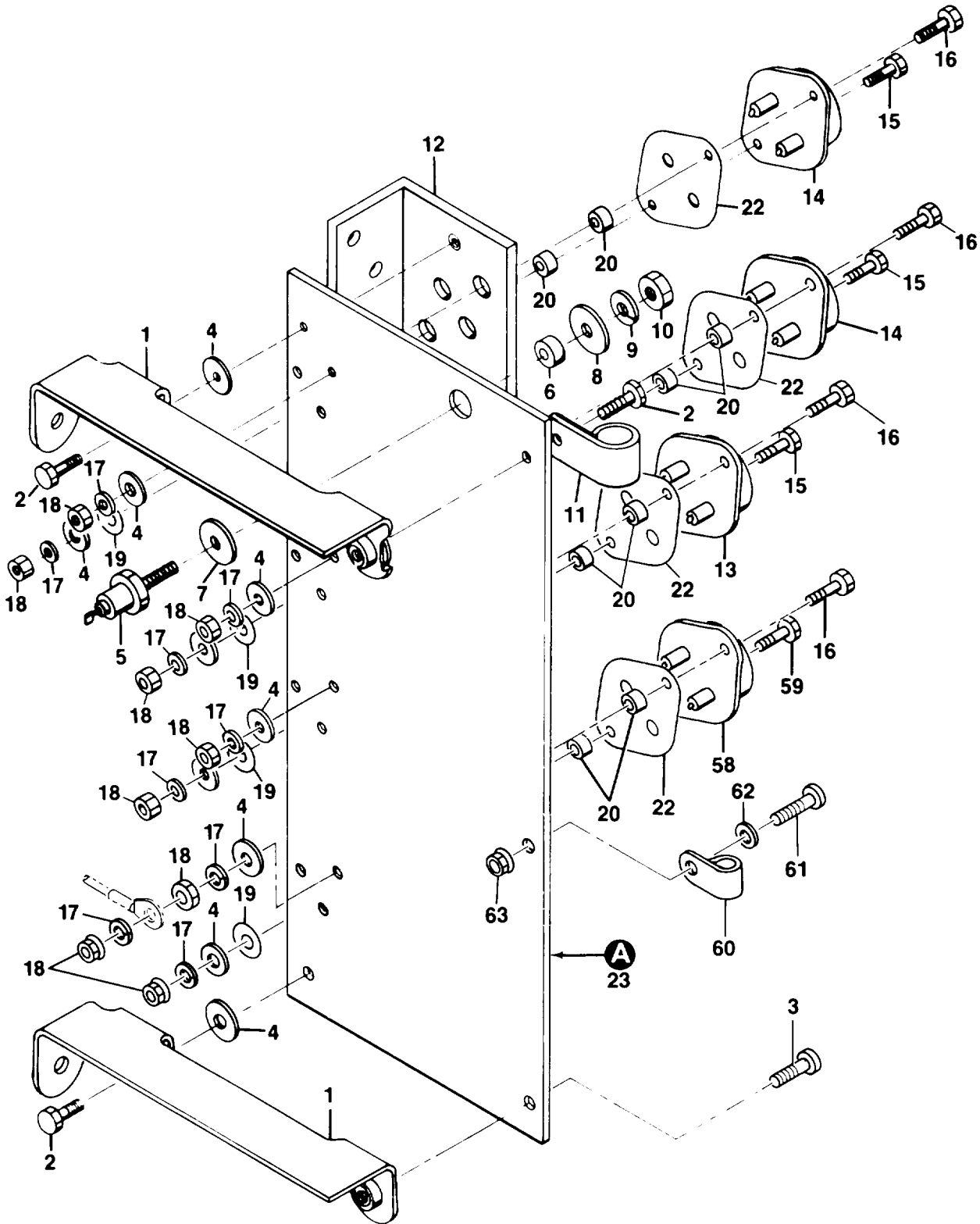


FIGURE C-8. HEATSINK ASSY, POWER (SHEET 1 OF 2)

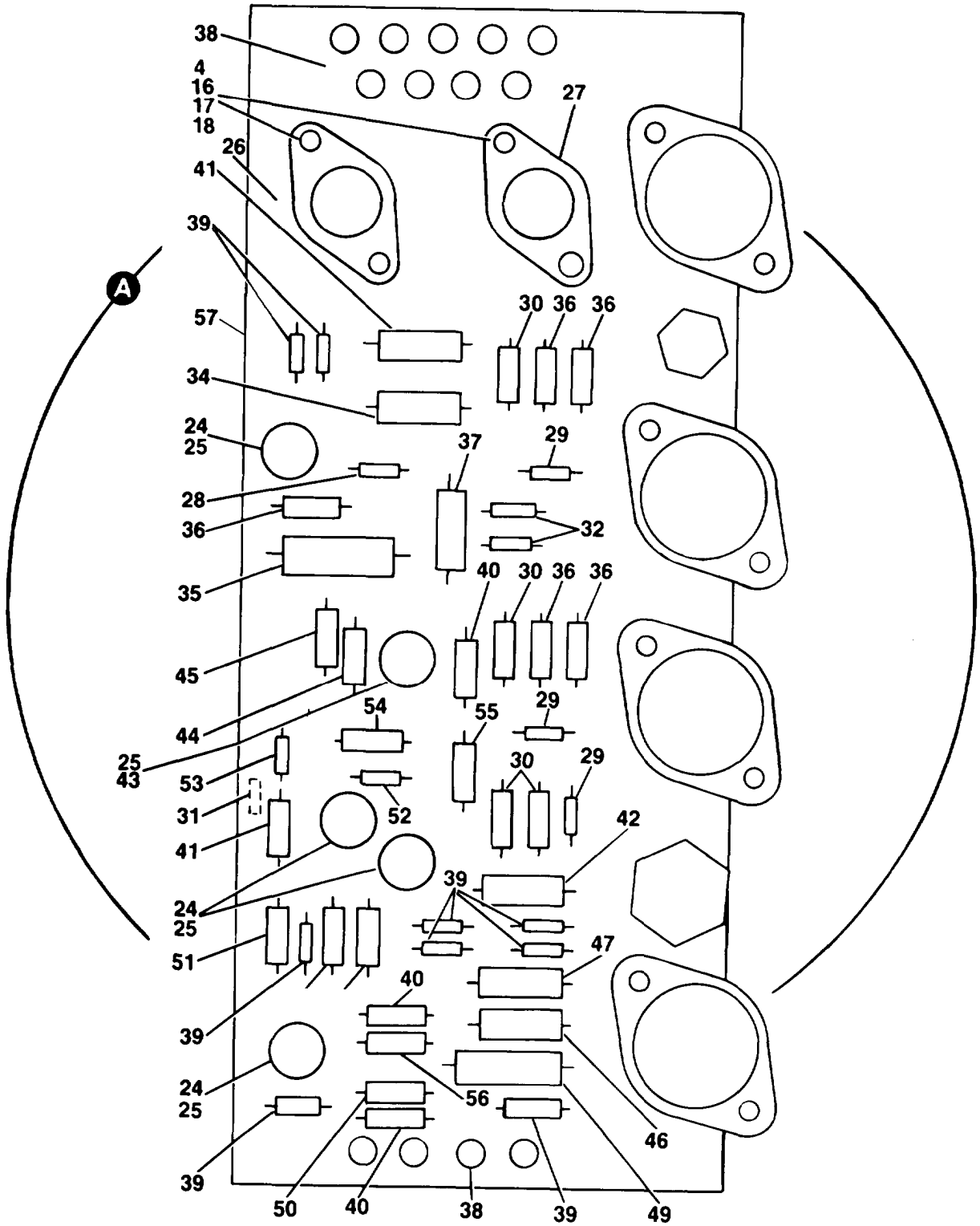


FIGURE C-8. HEATSIATK ASSY, POWER (SHEET 2 OF 2)

TM 55-1680-320-23&P

(1) ITEM NO.	(2) SMR CODE	(3) FSCM	(4) PART NUMBER	(5) DESCRIPTION AND USABLE ON CODE (UOC)	(6) QTY
				GROUP 03: CONTROL PANEL ASSEMBLY	
				FIG. C-8. HEATSINK ASSY, POWER	
	PBDDD	82402	19225-3	HEATSINK ASSY, POWER (SEE FIG, C-6 FOR NHA)	REF
1	XADZZ	82402	19223	. BRACKET	2
2	PADZZ	96906	MS21096-06003	. SCREW, SELF-LOCK	3
3	PADZZ	96906	MS21096-06001	. BOLT	1
4	PADZZ	88044	AN960-6	. WASHER (AP)	14
5	PADZZ	81349	JANIN2973B	. DIODE, ZENER(VR202)	1
6	PADZZ	88818	A312A095-101	. SPACER (AP) (08289)	1
7	PADZZ	08289	MW-562-203-002	. WASHER, MICA	1
8	PADZZ	88044	AN960-10L	. WASHER, FLAT	1
9	PADZZ	96906	MS35338-100	. WASHER, LOCK	1
10	PADZZ	96906	MS25082S3	. NUT	1
11	PADZZ	96906	MS25281-F6	. CLAMP	1
12	XADZZ	82402	19078	. HEATSINK	1
13	PBDZZ	27014	LM109KSTL/883B	. REGULATOR, VOLTAGE (U303)	1
14	PBDZZ	26916	058-001253	. REGULATOR, VOLTAGE (U301 , U302)	2
15	PADZZ	96906	MS35206-327	. SCREW	3
16	PADZZ	96906	MS35206-229	. SCREW	8
17	PADZZ	96906	MS35338-98	. WASHER, LOCK	13
18	PADZZ	96906	MS21042L06	. NUT, SELF-LOCK	12
19	PADZZ	08289	MW-296-140	. WASHER, MICA	4
20	PADZZ	08289	TW-147-236-094N	. SPACER (AP)	8
21	PADZZ	96906	MS35649-265	. NUT(AP)	1
22	PADZZ	08289	DM-123	. INSULATOR, MICA	8
23	PADDD	82402	19076-3	. PC BOARD, POWER SUPPLY.	1
24	PADZZ	81349	JAN2N2219A	. . TRANSISTOR	4
25	PADZZ	09448	HY515-1	. . PAD, MOUNTING	5
26	PADZZ	04713	2N4912	. . TRANSISTOR(Q202)	1
27	PADZZ	80131	2N3741A	. .TRANSISTOR(Q203)	1
28	XDDZZ	27014	1N4751A	. . DIODE, ZENER (VR201)	1
29	PADZZ	04713	MR811	. . DIODE(CR237-CR239)	3
30	PADZZ	81349	M39003-01-3006	. . CAPACITOR (C201, C204-C206)	4
31	PADZZ	81349	M39003/01-3076	. . CAPACITOR	1
32	XDDZZ	32897	814150651225M 50V	. . CAPACITOR (C202, C203)	2
33	PADZZ	81349	M39003/01-3100	. . CAPACITOR (C200)	1
34	PADZZ	81349	RCR32G471JS	. . RESISTOR (R201)	1
35	XDDZZ	81349	RWP21F6800F	. . RESISTOR(R202)	1
36	PADZZ	81349	RNC60H1001FS	. . RESISTOR (R203, R207, R208, R209, R 210)	5
37	PADZZ	81349	RCR32G331JS	. . RESISTOR (R204)	1
38	PADZZ	08866	1125C	. . TERMINAL	13
39	PADZZ	81349	JAN1N3611	. . DIODE(CR402, 407,409,411)	9

TM 55-1680-320-23&P

(1) ITEM NO.	(2) SMR CODE	(3) FSCM	(4) PART NUMBER	(5) DESCRIPTION AND USABLE ON CODE (UOC)	(6) QTY
40	PADZZ	81349	RCR20G102JS	.. RESISTOR(R407,R410,R413)	3
41	PADZZ	81349	RCR20G201JS	.. RESISTOR (R401).....	1
42	PADZZ	81349	RCR32G102JS	.. RESISTOR(R409)	1
43	PADZZ	81349	JAN2N2905A	.. TRANSISTOR(Q402)	1
44	PADZZ	81349	RCR20G330JS	.. RESISTOR(R403)	1
45	PADZZ	81349	RCR20G154JS	.. RESISTOR(R404)	1
46	PADZZ	81349	RCR32G152JS	.. RESISTOR(R412)	1
47	PADZZ	81349	RCR32G202JS	.. RESISTOR(R411)	1
48	PADZZ	81349	M39003-01-3023	.. CAPACITOR(C402)	1
49	PADZZ	81349	M39003-01-3094	.. CAPACITOR(C403)	1
50	PADZZ	81349	RCR20G101JS	.. RESISTOR(R416)	1
51	PADZZ	81349	RCR20G393JS	.. RESISTOR(R402,R406).....	2
52	XDDZZ	27014	1N4742A	.. DIODE, ZENER(VR401)	1
53	PADZZ	81349	M39014/02-1338	.. CAPACITOR (C401)	1
54	PADZZ	81349	RCR20G474JS	.. RESISTOR(R405).....	1
55	PADZZ	81349	RCR20G273JS	.. RESISTOR(R408)	1
56	PADZZ	81349	RCR20G222JS	.. RESISTOR(R415)	1
57	XADZZ	82402	19075	.. PC BOARD.	1
58	PADZZ	81349	JAN2N6284	. TRANSISTOR.....	1
59	PADZZ	96906	MS35206-231	. SCREW.....	1
60	PAFZZ	96906	MS25281-F3	. CLAMP	1
61	PADZZ	96906	MS35206-327	. SCREW.....	1
62	PADZZ	88044	AN960-6	. WASHER	1
63	PADZZ	96906	MS21042L06	. NUT	1
END OF FIGURE					

**THIS PAGE
INTENTIONALLY
LEFT BLANK**

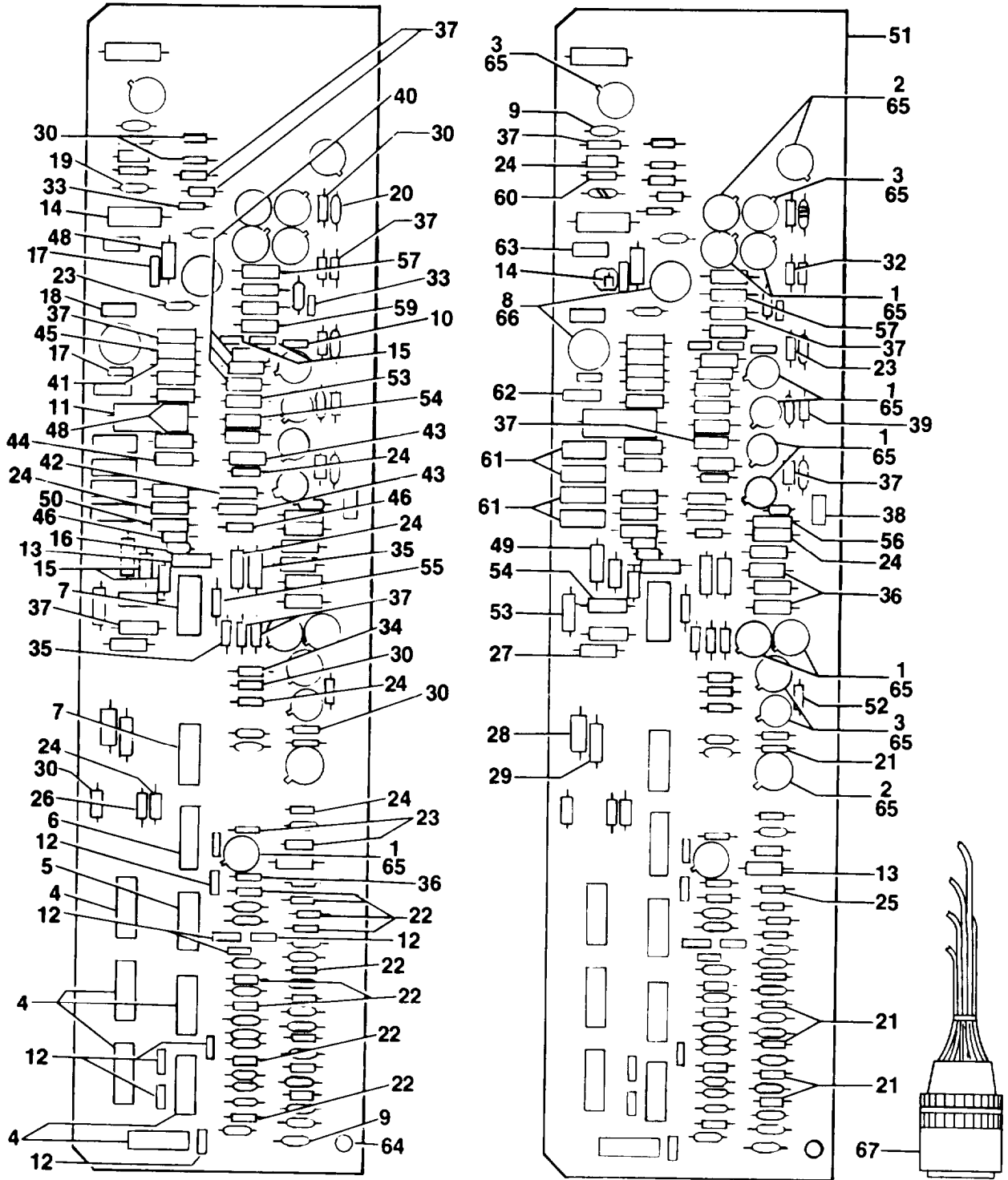


FIGURE C-9. PCB ASSY, LOGIC

TM 55-1680-320-23&P

(1) ITEM NO.	(2) SMR CODE	(3) FSCM	(4) PART NUMBER	(5) DESCRIPTION AND USABLE ON CODE (UOC)	(6) QTY
				GROUP 03: CONTROL PANEL ASSEMBLY	
				FIG. C-9. PCB ASSY, LOGIC	
				PCB ASSY, LOGIC (SEE FIG. C-6 FOR NHA) . . .	REF
1	PADDD	82402	19246	. TRANSISTOR (Q1, Q7, Q8, Q10-Q15)	9
2	PADZZ	81349	JAN2N2219A	. TRANSISTOR (Q3, Q5, Q6)	3
3	PADZZ	81349	JAN2N2905A	. TRANSISTOR (Q4, Q9, Q16, Q17)	4
4	PADZZ	04713	2N5682	. INTEGRATED CIRCUIT (U1, U2, U3, U4,	6
				U5, U7,)	
5	XDDZZ	82402	5400	. INTEGRATED CIRCUIT (U6)	1
6	XDDZZ	27014	5402	.INTEGRATED CIRCUIT(U8)	1
7	XDDZZ	27014	5425	. INTEGRATED CIRCUIT (U9, U10)	2
8	PADZZ	14933	7704301CB	. INTEGRATED CIRCUIT (U11, U13)	2
9	PADZZ	27014	LM101AH	.DIODE(CR1-CR22,CR26,CR28	31
				CR30,CR32-CR36,CR44)	
10	PADZZ	81349	JAN1N914B	. CAPACITOR (C30)	1
11	PADZZ	81349	M39014/02-1338	. CAPACITOR (C25)	1
12	PADZZ	81349	M39003-01-0370	. CAPACITOR (C1-C8, C17)	9
13	PADZZ	81349	M39014-02-1342	. CAPACITOR (C9, C24)	2
14	PADZZ	81349	M39003-01-3076	. CAPACITOR (C29, C31)	2
15	PADZZ	81349	M39034-01-3006	. CAPACITOR(C19,C22,C26,C27)	4
16	PADZZ	81349	M39014-02-1350	. CAPACITOR (C23)	1
17	PADZZ	81349	M39014-01-1357	. CAPACITOR (C21, C28)	2
18	PADZZ	81349	M39014-01-1330	.CAPACITOR (C20)	1
19	PADZZ	81349	M39014-01-1321	.DIODE, ZENER (VR4)	1
20	PADZZ	81349	JAN1N753A	.DIODE, ZENER (VR2)	1
21	PADZZ	81349	JAN1N751A	. RESISTOR (R1-R4, R28)	5
22	PADZZ	81349	RCR07G681JS	. RESISTOR (R5-R8, R13-R16)	8
23	PADZZ	81349	RCR07G272JS	. RESISTOR (R11, R9, R62, R63)	4
24	PADZZ	81349	RCR07G103JS	. RESISTOR (R10, R21, R53, R80,	8
				R82,R108,R54,R58)	
25	PADZZ	81349	RNC60H1002FS	. RESISTOR (R12)	1
26	PADZZ	81349	RCR07G472JS	. RESISTOR (R17)	1
27	PADZZ	81349	RNC60H6652FS	. RESISTOR (R52)	1
28	PADZZ	81349	RCR20G471JS	. RESISTOR (R19)	1
29	PADZZ	81349	RNC60H2152FS	. RESISTOR (R23)	1
30	PADZZ	81349	RCR07G202JS	. RESISTOR (R29, R34, R36, R39	8
				R45-R47,R93)	
31	PADZZ	81349	RCR07G102JS	. RESISTOR(R35,R37,R38,R48,R49)	5
32	PADZZ	81349	RCR07G332JS	. RESISTOR (R40)	1
33	PADZZ	81349	RCR20G471JS	. RESISTOR (R41, R42)	2
34	PADZZ	81349	RCR07G512JS	. RESISTOR (R44)	1
35	PADZZ	81349	RCR07G682JS	. RESISTOR (R50, R51)	2
36	PADZZ	81349	RNC60H3832FS	. RESISTOR (R55, R57)	2
37	PADZZ	81349	RNC60H4641FS	. RESISTOR (R60, R68, R69, R78	7
				R88,R100,R107)	

TM 55-1680-320-23&P

(1) ITEM NO.	(2) SMR CODE	(3) FSCM	(4) PART NUMBER	(5) DESCRIPTION AND USABLE ON CODE (UOC)	(6) QTY
38	PADZZ	81349	RCR07G33IJS	. RESISTOR (R59)	1
39	PADZZ	81349	RCR07G203JS	. RESISTOR (R61)	1
40	PADZZ	81349	RNC60H9091FS	. RESISTOR (R64, R67, R77)	3
41	PADZZ	81349	RNC60H1003FS	. RESISTOR (R66)	1
42	PADZZ	81349	RCR07G185JS	. RESISTOR (R70)	1
43	PADZZ	81349	RNC60H3922FS	. RESISTOR (R71, R72)	2
44	PADZZ	81349	RNC60H2802FS	. RESISTOR (R74)	1
45	PADZZ	81349	RNC60H9532FS	. RESISTOR (R76)	1
46	PADZZ	81349	RNC60H6191FS	. RESISTOR (R81, R83)	2
47	PADZZ	81349	RNC60H2213FS	. RESISTOR (R79)	1
48	PADZZ	81349	RNC60H6192FS	. RESISTOR (R90, R97)	2
49	PADZZ	81349	RNC60H6651FS	. RESISTOR (R85)	1
50	PADZZ	81349	RNC60H3923FS	. RESISTOR (R86)	1
51	PADDD	82402	19248	. PC BOARD	1
52	PADZZ	81349	RCR07G222JS	. RESISTOR (R91)	1
53	PADZZ	81349	RNC60H2052FS	. RESISTOR (R94, R98)	2
54	PADZZ	81349	RNC60H8062FS	. RESISTOR (R95, R96)	2
55	PADZZ	81349	RNC60H1272FS	. RESISTOR (R99)	1
56	PADZZ	81349	RCR07G223JS	. RESISTOR (R101)	1
57	PADZZ	81349	RNC60H4991FS	. RESISTOR (R103)	1
58	PADZZ	81349	RNC60H4492FS	. RESISTOR (R105, R106)	2
59	PADZZ	81349	RNC60H4751FS	. RESISTOR (R102)	1
60	PADZZ	81349	RNC60H2001FS	. RESISTOR (R109)	1
61	PADZZ	32997	3252-W-1-102	. RESISTOR, POT (R65, R84, R89, R73)	4
62	PADZZ	32997	3252-W-1-103	. RESISTOR, POT (R75)	1
63	PADZZ	32997	3252-W-1-501	. RESISTOR, POT (R104)	1
64	PADZZ	81349	SE16XC02	. TERMINAL	48
65	PADZZ	09448	HY515-1	. PAD, MOUNTING	1
66	PADZZ	08289	508-050-NY	. PAD, MOUNTING	2
67	PADZZ	96906	MS3116E18-32S	. CONNECTOR	1
END OF FIGURE					

**THIS PAGE
INTENTIONALLY
LEFT BLANK**

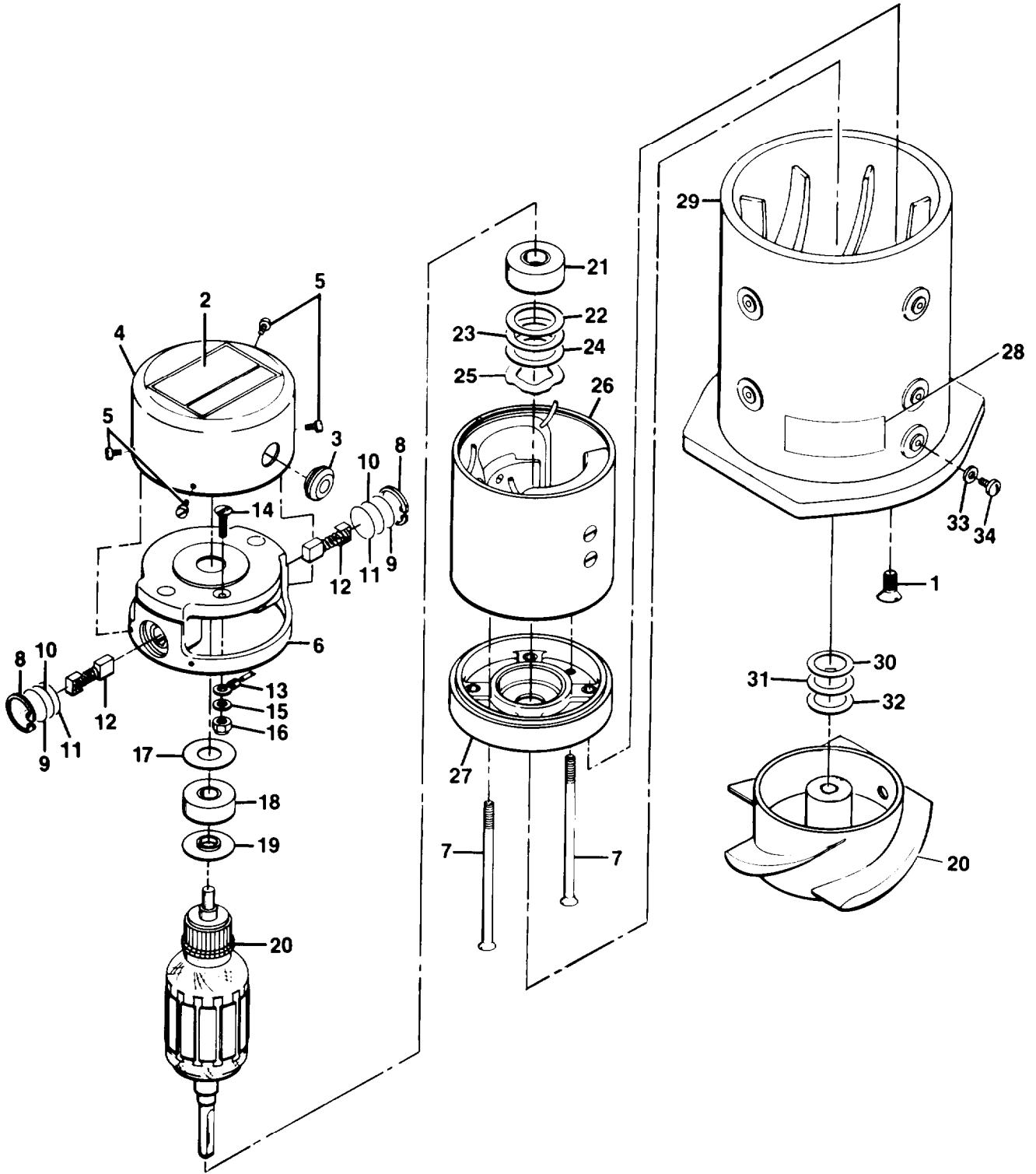


FIGURE C-10. BLOWER ASSYDC MOTOR

TM 55-1680-320-23&P

(1) ITEM NO.	(2) SMR CODE	(3) FSCM	(4) PART NUMBER	(5) DESCRIPTION AND USABLE ON CODE (UOC)	(6) QTY
				GROUP 0301: MOTOR ASSEMBLY, DC	
				FIG. C-10. BLOWER ASSY/DC MOTOR	
	PAFDD	82402	FV3-4	BLOWER ASSY, FAN (SEE FIG. C-6 FOR NHA)	REF
1	PADZZ	96906	MS35190-269	. SCREW	4
2	XDDZZ	82402	149099	. NAMEPLATE	1
	PADDD	82402	239YC33	.MOTOR ASSY,DC.	1
3	PADZZ	23172	2171	. . GROMMET	1
4	PADZZ	82402	10982	. . COVER, END	1
5	PADZZ	96906	MS35265-1	. . SCREW	4
6	PBDZZ	82402	15433	. . END BELL ASSY, BRUSHHOLDER	1
7	PADZZ	82402	10981-1	. . BOLT.	2
8	PADZZ	79136	N5001-56MD	. . RING, RETAINER	2
9	PADZZ	82402	15205-1	. . DISC	2
10	PADZZ	82402	15205-2	. . DISC, INSULATING	2
11	PADZZ	82402	15205-3	. . DISC	2
12	PADZZ	82402	80314	. . BRUSH ASSY	2
13	PADZZ	96906	MS25036-101	. . TERMINAL	1
14	PADZZ	96906	MS35190-224	. . SCREW	1
15	PADZZ	88044	AN960-4L	. . WASHER	1
16	PADZZ	22599	22NTM-40	. . NUT, SELF-LOCK	1
17	PADZZ	82402	886-7	. . SHIM	1
18	PADZZ	43334	77035LR1CJ3	. . BEARING, BALL	1
19	PADZZ	82402	1209-5	. . SLINGER	1
20	PBDZZ	82402	36782	. . ARMATURE AND IMPELLER ASSY	1
21	PADZZ	43334	SS77038LR3053E9	. . BEARING, BALL	1
22	PADZZ	82402	886-5	. . SHIM	1
23	PADZZ	82402	886-12	. . SHIM	1
24	PADZZ	82402	886-144	. . SHIM	1
25	PADZZ	82402	146687	. . WASHER, WAVY SPRING	1
26	PBDZZ	00462	21875	. . YOKE ASSY	1
27	PBDZZ	82402	15250	. . END BELL ASSY, FRONT	1
28	PADZZ	82402	12554-3	. NAMEPLATE.	1
29	PADZZ	82402	19515	. SHROUD ASSY.	1
30	PADZZ	82402	886-1	. SHIM	1
31	PADZZ	82402	886-29	. SHIM	1
32	PADZZ	82402	886-211	. SHIM	1
33	PADZZ	96906	MS35333-38	. WASHER, LOCK	1
34	PADZZ	96906	MS35206-240	. SCREW	1
				END OF FIGURE	

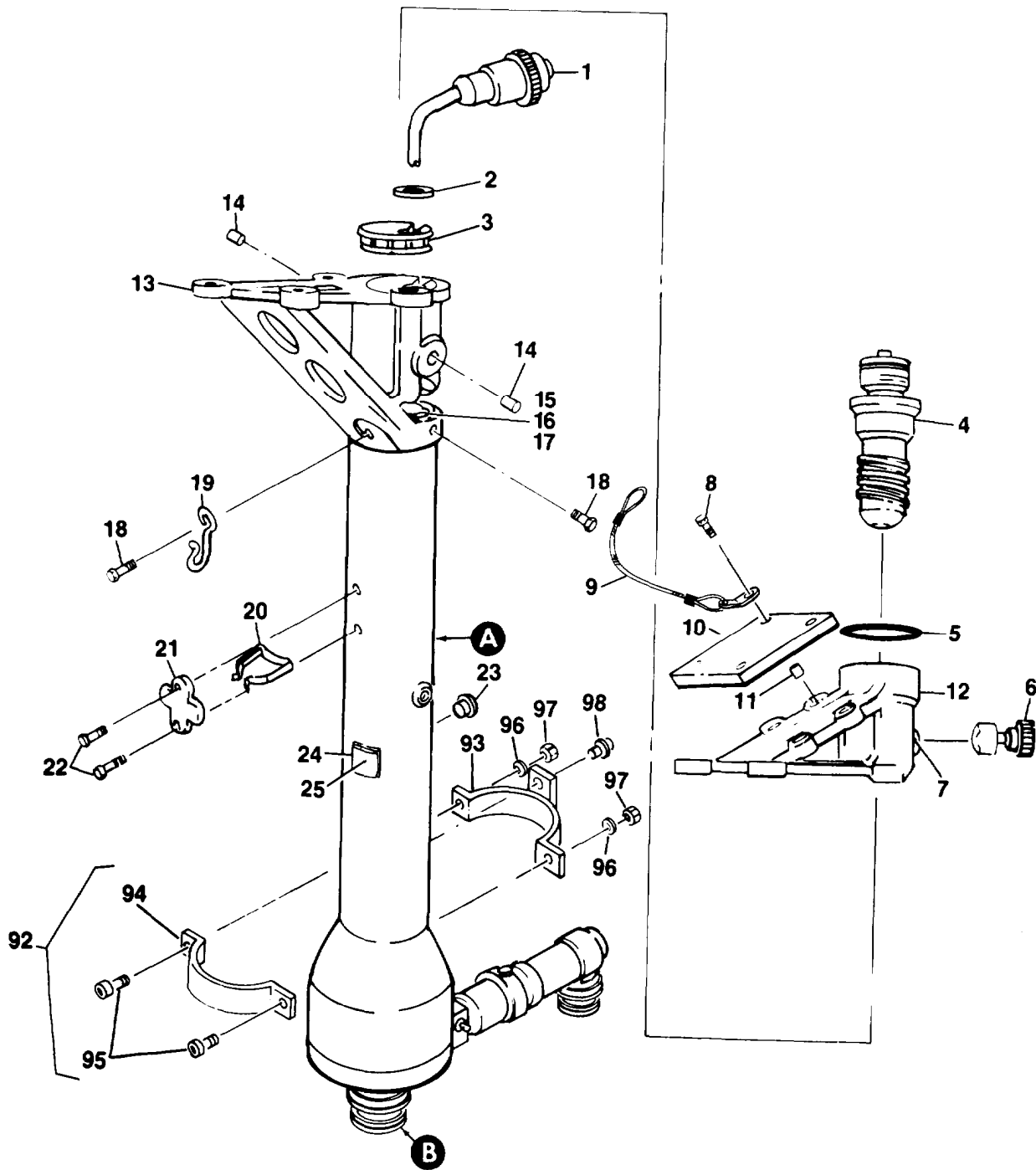


FIGURE C-11. BOOM POSITION SUPPORT ASSY (SHEET 1 OF 3)

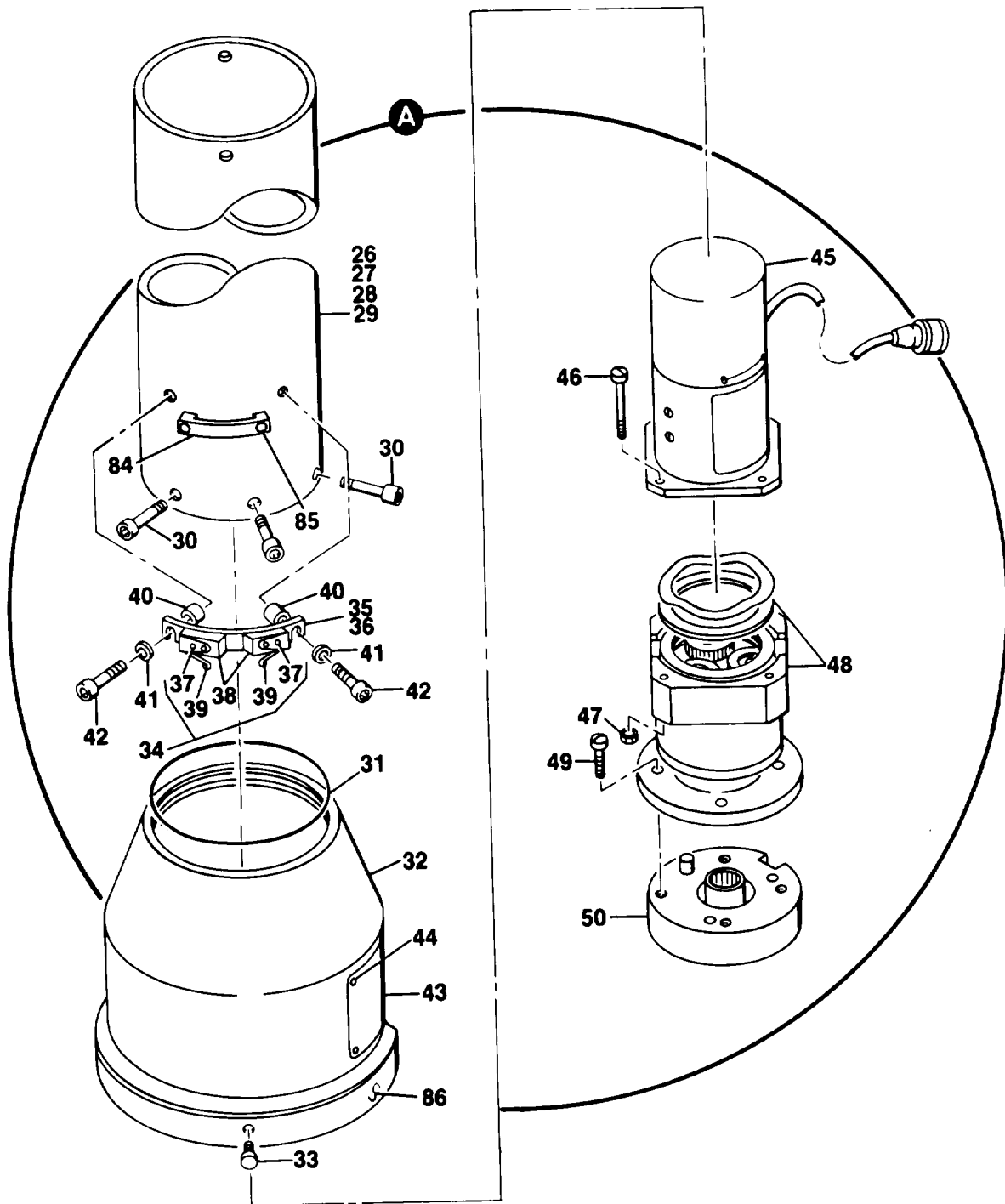


FIGURE C-11. BOOM POSITION SUPPORT ASSY (SHEET 2 OF 3)

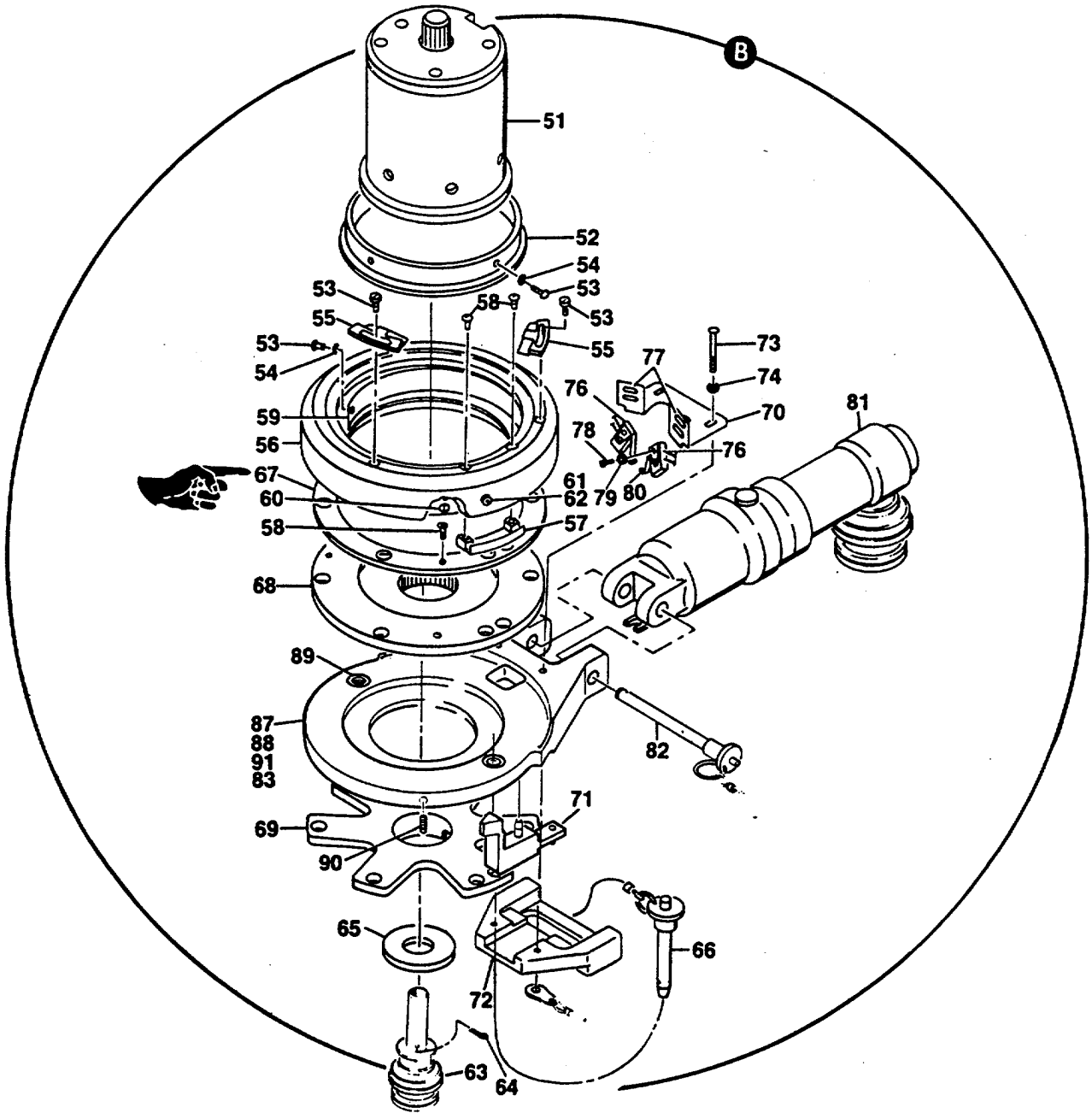


FIGURE C-11. BOOM POSITION SUPPORT ASSY (SHEET 3 OF 3)

(1) ITEM NO.	(2) SMR CODE	(3) FSCM	(4) PART NUMBER	(5) DESCRIPTION AND USABLE ON CODE (UOC)	(6) QTY
GROUP 04: BOOM POSITION SUPPORT, ASSEMBLY					
FIG.C-11 BOOM POSITION SUPPORT ASSY					
	PBFDD	824023	42305R500	BOOM POSITION SUPPORT ASSEMBLY (SEE FIG. C-1 FOR NHA)	REF
1	PAOZZ	96906	MS3126E14-12P	CONNECTOR	1
2	PAOZZ	88044	AN931-8-13	GROMMET	1
3	PBFZZ	82402	42277E594	PLATE, STANCHION COVER	1
4	PAOOO	82402	42305D528	HEIGHT ADJUSTER ASSY (SEE FIG. C-16 FOR BREAKDOWN)	1
5	PCOZZ	96906	MS28775-133	PACKING, PREFORMED	1
6	PBOZZ	01226	SL375	PLUNGER	1
7	PAOZZ	96906	MS51973-112	SETSCREW	1
8	PAFZZ	96906	MS35207-261	SCREW	4
9	PADZZ	82402	42305-613	SAFETY CLIP AND LANYARD	1
10	XDFZZ	82402	42277D528-5	COVER PLATE	1
11	PAFZZ	80205	NAS1394C3L	INSERT	4
12	XDFFF	82402	42277R522	SUPPORT ASSY, UPPER	1
13	XDFDD	82402	42277R521	SUPPORT ASSY, LOWER	1
14	PADZZ	29372	KNL524	INSERT	2
15	PBFFF	82402	42277D523	NUT-ANCHOR RING ASSY	1
16	PBFZZ	75237	F2400-5	NUT-ANCHOR	4
17	PAFZZ	96906	MS20426DD4-6	RIVET	8
18	PAOZZ	88044	AN175H10A	SCREW	4
19	PAOZZ	82402	42277E539	HOOK	1
20	PAOZZ	82402	42277D598	SPRING	1
21	PBOZZ	82402	42277E596	RETAINER-HOOK	1
22	PAOZZ	80205	NAS1352-08H4	SCREW	2
23	PAOZZ	82402	42305-614	PLUG	1
24	XDDZZ	82402	42305C534	PLATE, IDENTIFICATION	1
25	PADZZ	96906	MS21318-7	SCREW, DRIVE	4
26	XDDDD	82402	42305R530	STANCHION TUBE ASSY	1
27	XADZZ	82402	42305R530-1	TUBE	1
28	XADZZ	82402	42305R565	BOSS	2
29	XADZZ	98004	KNL524	INSERT	2
30	PADZZ	88044	AN174CH6A	BOLT	6
31	PADZZ	96906	MS28775-238	PACKING, PREFORMED	1
32	PADZZ	82402	42277R578	COVER, SWITCH ASSY	1
33	PADZZ	96906	MS16998-19	SCREW	2
34	XDDDD	82402	42277D597	LIMIT SWITCH ASSY	1
35	PBDZZ	82402	42277D577	BRACKET, SWITCH	1
36	PBDZZ	82402	4067C193	NUT PLATE ASSY	2
37	PADZZ	96906	MS1957-9	SCREW	4
38	PADZZ	91929	1SE2-6	MICRO SWITCH	2

(1) ITEM NO.	(2) SMR CODE	(3) FSCM	(4) PART NUMBER	(5) DESCRIPTION AND USABLE ON CODE (UOC)	(6) QTY
39	PADZZ	91929	JE5	SWITCH ACTUATOR	2
40	PADZZ	80205	NAS43DD1-16	SPACER	2
41	PADZZ	80205	NAS620-6L	WASHER	2
42	PADZZ	80205	NAS1352-06H8	SCREW	2
43	PADZZ	82402	42305E592	PLATE,HOIST POSITION	1
44	PADZZ	81349	M24243/1-A302	RIVET	4
45	PADDD	82402	239YC32	MOTOR,BOOM POSTION (SEE FIG. C-12 FOR BREAKDOWN)	1
46	PADZZ	96906	MS35265-50	SCREW	4
47	PADZZ	96906	MS21042L08	NUT,SELF-LOCK	4
48	PADDD	82402	42277E600	GEAR DRIVE ASSY (SEE FIG.C-13 FOR BREAKDOWN)	1
49	PADZZ	96906	MS35265-52	SCREW	4
50	PAFDD	82402	42305E540	MECHANICAL STOP ASSY (SEE FIG. C-14 FOR BREAKDOWN)	1
51	PADDD	82402	42305E555	ROTARY ACTUATOR ASSY (SEE FIG. C-15 FOR BREAKDOWN)	1
52	PBDZZ	82402	42305D537	RING,CONDUCTOR HOLD DOWN	1
53	PADZZ	96906	MS35206-226	SCREW	7
54	PADZZ	88044	AN960PD6L	WASHER,FLAT	1
55	PADZZ	82402	42305D585	CAM,LIMIT SWITCH	2
56	PBDZZ	82402	42305E554	SUPPORT,LIMIT SWITCH CAM	1
57	PBDZZ	82402	42305D572	CLAMP,LIMIT SWITCH	1
58	PADZZ	96906	MS24693-S24	SCREW	5
59	PBFZZ	82402	42305R568	HARNES, FLEX WIRE	1
60	PADZZ	96906	MS35206-213	SCREW	4
61	PAFZZ	96906	MS35206-212	SCREW	1
62	PAFZZ	88044	AN960C4L	WASHER,FLAT	1
63	PAOZZ	80402	42305E561	QUICK DISCONNECT	1
64	PAOZZ	96906	MS24665-359	PIN,COTTER	1
65	PAFZZ	82402	42305C533	WASHER	1
66	PAFZZ	82402	42277D587	PIN ASSY	2
67	PBDDD	82402	42305E536	BASE PLATES,MATCHED SET	1
68	XADZZ	82402	42305E531	UPPER BASE PLATE ASSY	1
69	XADZZ	82402	42305E532	LOWER BASE PLATE ASSY	1
70	PADZZ	82402	42277D591	BRACKET,OVERLOAD SWITCH	1
71	PAFZZ	82402	42305D519	LEVER ASSY	1
72	PAFZZ	82402	42305E571	PLATE	1
73	PADZZ	96906	MS35265-52	SCREW	2
74	PADZZ	88044	AN960PD8L	WASHER	4
75	PADZZ	96906	MS21083N08	NUT	2
76	PAFZZ	91929	1SE2	LIMIT SWITCH	2
77	PAFZZ	82402	4067C193	NUT PLATE ASSY	2
78	PAFZZ	96906	MS51957-9	SCREW	4
79	PADZZ	80205	NAS620-6L	WASHER	2
80	PAFZZ	91929	JE5	ACTUATOR, SWITCH	2
81	PAODD	82402	42305E510	REACTION ARM ASSY (SEE FIG.C-17 FOR BREAKDOWN)	1

TM 55-1680-320-23&P

(1) ITEM NO.	(2) SMR CODE	(3) FSCM	(4) PART NUMBER	(5) DESCRIPTION AND USABLE ON CODE (UOC)	(6) QTY
82	PAFZZ	82402	42305D573	. PIN ASSY	1
83	PBFZZ	82402	42305E535	.FLANGE,MOUNTING	1
84	PADZZ	82402	42305D574	. CLAMP	1
85	PADZZ	96906	MS24693-S25	. SCREW	2
86	PADZZ	82402	42305D599	. RING	1
87	PBFFF	82402	42305E593	. PLATE ASSY, REACTION	1
88	XAFZZ	82402	42305E593-1	. . PLATE	1
89	PAFZZ	82402	42305D553	. . BUSHING	2
90	PAFZZ	96906	MS21209F0815	. . INSERT	2
91	PAFZZ	82402	42305D567	. . PIN	1
92	PAOZZ	82402	42305E590	. STUD RING ASSY	1
93	XAOZZ	82402	42305E591	. . STUD RING	1
94	XAOZZ	82402	42305-615	. . CLAMP	1
95	XAOZZ	80205	NAS1351-3-10P	. . SCREW	2
96	XAOZZ	88044	AN960-10C	. . WASHER	4
97	PAOZZ	96906	MS21044N3	. . NUT	2
98	XDOZZ	82402	42305E594	. . STUD	1
END OF FIGURE					

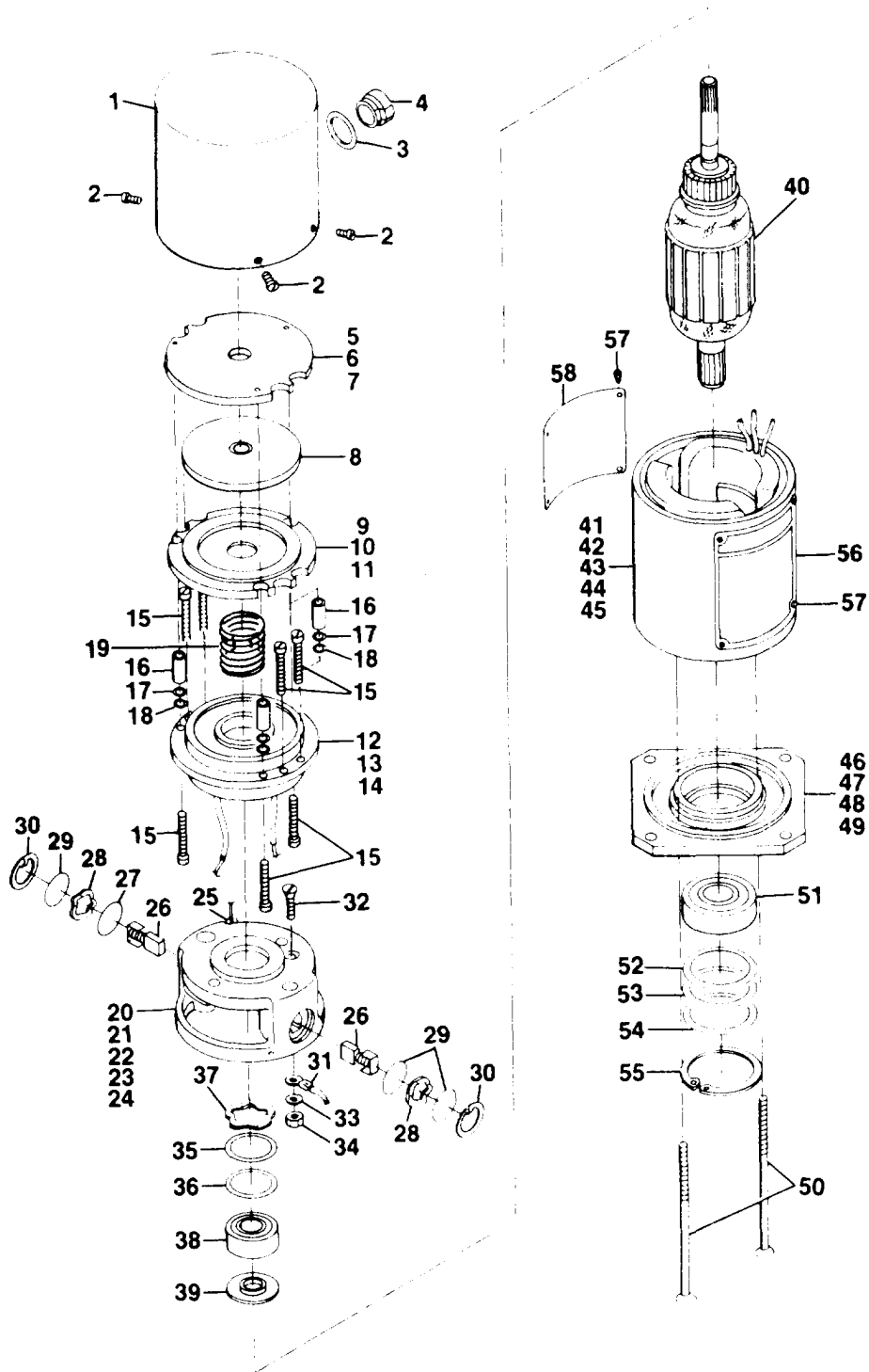


FIGURE C-12. MOTOR, BOOM POSITION

TM 55-1680-320-23&P

(1) ITEM NO.	(2) SMR CODE	(3) FSCM	(4) PART NUMBER	(5) DESCRIPTION AND USABLE ON CODE (UOC)	(6) QTY
				GROUP 04: BOOM POSITION SUPPORT ASSEMBLY	
				FIG. C-12. MOTOR, BOOM POSITION	
	PADDD	82402	239YC32	MOTOR, BOOM POSITION (SEE FIG. C-11 FOR NHA)	REF
1	XDDZZ	82402	14304-1	. END COVER	1
2	PADZZ	96906	MS35265-2	. SCREW	4
3	PADZZ	96906	MS28775-111	. PACKING, PREFORMED	1
4	PADZZ	28520	SR5P4	. BUSHING, RELIEF	1
5	PADDD	82402	14302	. BRAKE PLATE ASSY	1
6	XADZZ	82402	14303	. . BRAKE PLATE	1
7	XADZZ	82402	1398-11	. . BRAKE SHOE	1
8	XDDDD	82402	32160	. BRAKE DISC	1
9	PADDD	82402	14301	. BRAKE ARMATURE ASSY.	1
10	XADDD	82402	14299	. . BRAKE ARMATURE	1
11	XADZZ	82402	1398-11	. . BRAKE SHOE	1
12	PADDD	82402	21724	. BRAKE BRACKET ASSY	1
13	XADZZ	82402	14298	. . BRACKET	1
14	XADZZ	82402	21725	. . COIL ASSY	1
15	PADZZ	96906	MS35265-19	. SCREW	7
16	PADZZ	82402	13781-2	. SPACER	3
17	PADZZ	82402	886-97	. SHIM	V
18	PADZZ	82402	886-121	. SHIM	V
19	PADZZ	82402	14300	. SPRING, BRAKE	1
20	PADDD	82402	19158	. BRUSHHOLDER & END BELL	1
21	XADZZ	82402	14295	. . ENDBELL	1
22	XDDZZ	82402	15208	. . BRUSH AND INSULATOR	1
23	XDDZZ	82402	15255	. . BRUSHHOLDER	1
24	PADZZ	88044	AN565D6H2	. . SETSCREW	2
25	PBDZZ	82402	80200-2	. FUSE, THERMAL	V
26	PADZZ	82402	8732	.BRUSH ASSY	2
27	PADZZ	82402	15205-2	. DISC, INSULATING	1
28	PADZZ	82402	80186	. WASHER, WAVY SPRING	2
29	PADZZ	82402	15205-1	. DISC	3
30	PADZZ	96906	MS16629-1056	. RING, RETAINING	2
31	PADZZ	96906	MS25036-101	. TERMINAL LUG	1
32	PADZZ	96906	MS35190-224	. SCREW	1
33	PADZZ	96906	MS27183-4	. WASHER	1
34	PADZZ	96906	MS21045-L04	. NUT, SELF-LOCK	1
35	PADZZ	82402	886-7	. SHIM	V
36	PADZZ	82402	886-11	. SHIM	V
37	PADZZ	82402	W0734-009	. WASHER, WAVY SPRING	1
38	PADZZ	24617	SS77R4XR3MIL G327246178	. BEARING, BALL	1
39	PADZZ	82402	1209-10	. SLINGER	1

TM 55-1680-320-23&P

(1) ITEM NO.	(2) SMR CODE	(3) FSCM	(4) PART NUMBER	(5) DESCRIPTION AND USABLE ON CODE (UOC)	(6) QTY
40	PADZZ	82402	36274	. ARMATURE ASSY	1
41	XADDD	82402	21722	. YOKE ASSEMBLY	1
42	XADZZ	82402	19136	. . MOTOR HOUSING	1
43	XADZZ	82402	2518	. . POLE PIECE	2
44	XADZZ	82402	21723	. . FIELD COIL	1
45	PADZZ	88044	AN505-6-7	. . SCREW	4
46	XBDDD	82402	19840	. FRONT END BELL ASSY	1
47	XDDZZ	82402	19204-1	. . PIN	1
48	XADZZ	82402	19840-1	. . ENDBELL	1
49	XDDZZ	82402	19852	. . INSERT	1
50	PADZZ	88044	AN505-6R44	. SCREW	2
51	PADZZ	43334	3L00	. BEARING, BALL	1
52	PADZZ	82402	886-94	. SHIM	V
53	PADZZ	82402	886-229	. SHIM	V
54	PADZZ	82402	886-231	. SHIM	V
55	PADZZ	96906	MS16625-4102	. RING, RETAINING	1
56	XDDZZ	82402	19856	. PLATE, IDENTIFICATION	1
57	PADZZ	96906	MS21318-7	. SCREW	8
58	XDDZZ	82402	19283	. PLATE, SCHEMATIC	1
END OF FIGURE					

**THIS PAGE
INTENTIONALLY
LEFT BLANK**

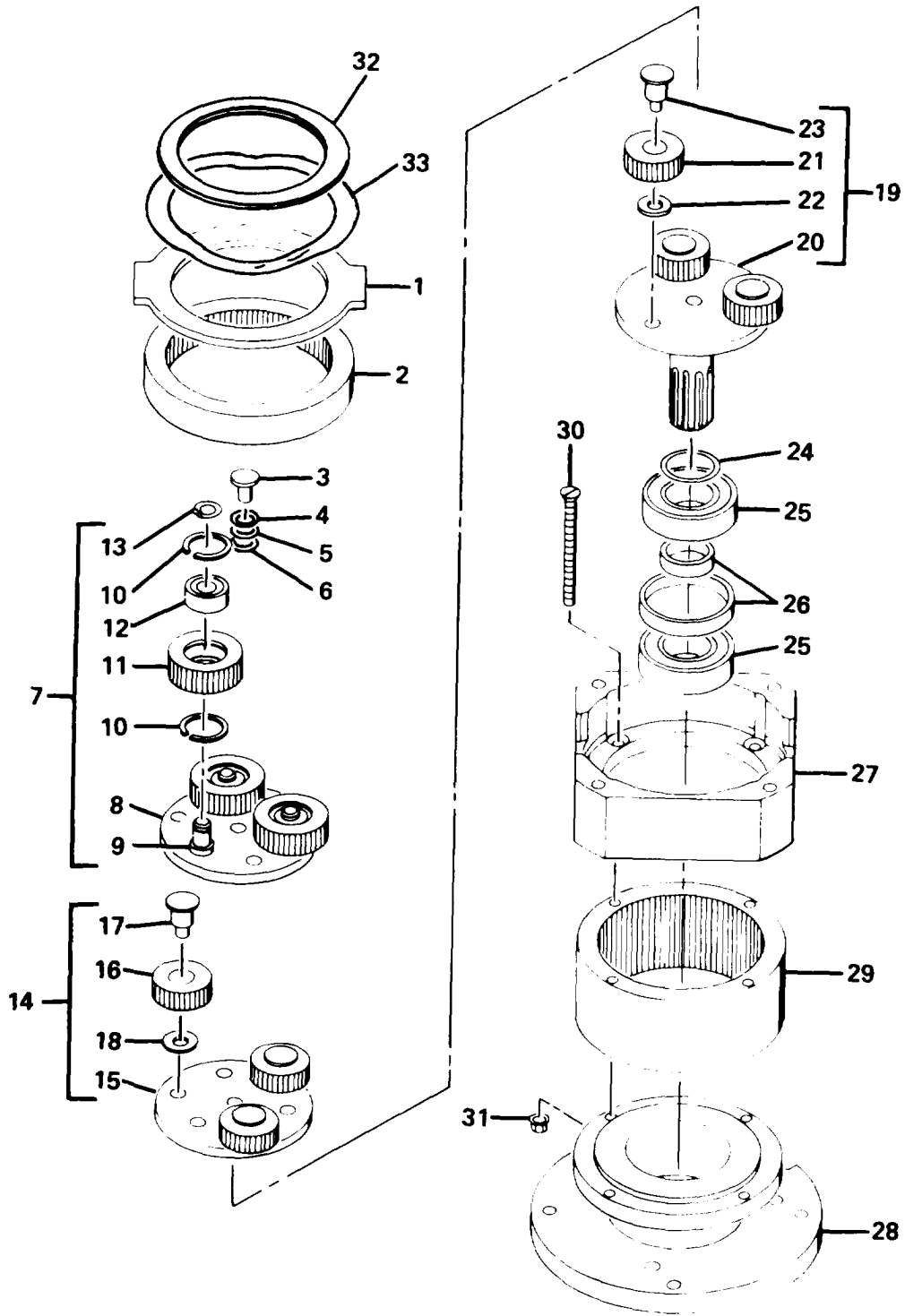


FIGURE C-13. GEAR DRIVE ASSY

TM 55-1680-320-23&P

(1) ITEM NO.	(2) SMR CODE	(3) FSCM	(4) PART NUMBER	(5) DESCRIPTION AND USABLE ON CODE (UOC)	(6) QTY
				GROUP 04: BOOM POSITION SUPPORT ASSEMBLY	
				FIG. C-13. GEAR DRIVE ASSY	
	PADDD	82402	42277E600	GEAR DRIVE ASSY (SEE FIG. C-11 FOR NHA) .	REF
1	PADZZ	82402	42277D605	. PLATE, PRESSURE	1
2	PADZZ	82402	42277D604	. RING GEAR, SHORT	1
3	PADZZ	82402	42277C615	. BUTTON, THRUST	1
4	PADZZ	82402	886-53	. SHIM	1
5	PADZZ	82402	886-108	. SHIM	1
6	PADZZ	82402	886-109	. SHIM	1
7	ADDDD	82402	36397	. PLANET CAGE ASSY	1
8	PADZZ	82402	36391	. . PLANET CAGE & SUNGEAR	1
9	PADZZ	82402	31546	. . PIN, GEAR	3
10	PADZZ	80756	RR50C	. . RING	6
11	PADZZ	82402	31547	. . GEAR, PLANET.	3
12	PADZZ	83086	SR33PPK58-168	. . BEARING, BALL	3
13	PADZZ	79136	5100-18	. . RING, RETAINING.	3
14	ADDDD	82402	36392	. PLANET CAGE ASSY	1
15	PADZZ	82402	36391	. . PLANET CAGE & SUNGEAR	1
16	PADZZ	82402	31531	. . GEAR, PLANET	3
17	PADZZ	82402	31530-1	. . PIN, GEAR.	3
18	PADZZ	82402	886-4	. SHIM	3
19	PADDD	82402	42277D616	. SHAW ASSY, OUTPUT	1
20	XADZZ	82402	42277D617	. . SHAFT, OUTPUT.	1
21	PADZZ	82402	31531	. . GEAR, PLANET.	3
22	PADZZ	82402	886-2	. . SHIM	3
23	PADZZ	82402	31530-1	. . PIN, GEAR	3
24	PADZZ	82402	886-13	. SHIM	1
25	PADZZ	43334	77R8XR1CJ3	. BEARING, BALL	2
26	PBDZZ	82402	13437	. SPACER SET	1
27	XDDZZ	82402	42277E603	. HOUSING, RING GEAR	1
28	PADZZ	82402	42277E601	. FLANGE ASSY, OUTPUT	1
29	PADZZ	82402	42277D602	. RING GEAR, LONG	1
30	PADZZ	96906	MS24693-S36	. SCREW	4
31	PADZZ	96906	MS21042L06	. NUT	4
32	PADZZ	82402	42277C610	. SHIM	1
33	PADZZ	92830	W2420-025	. WASHER	1
				END OF FIGURE	

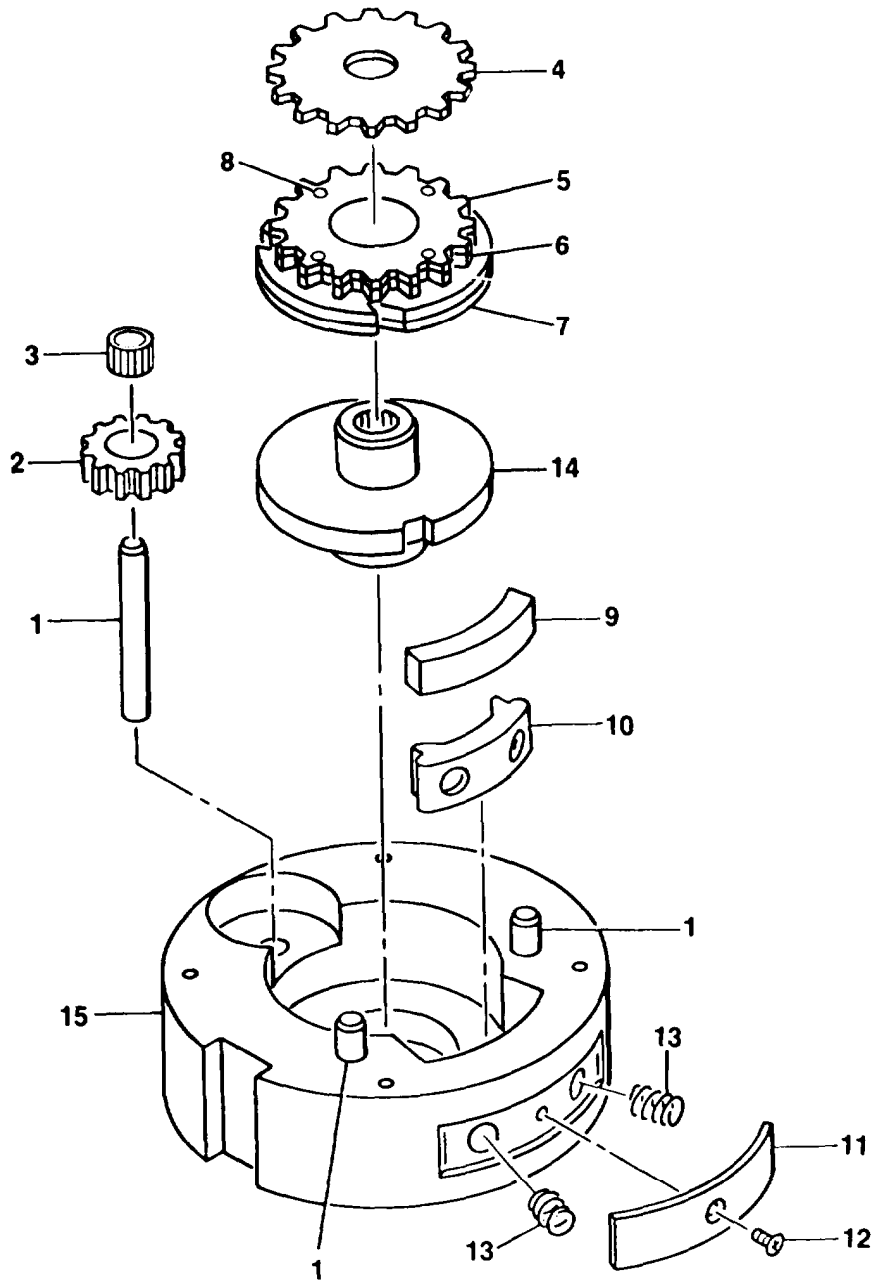


FIGURE C-14. MECHANICAL STOP ASSY

TM 55-1680-320-23&P

(1) ITEM NO.	(2) SMR CODE	(3) FSCM	(4) PART NUMBER	(5) DESCRIPTION AND USABLE ON CODE (UOC)	(6) QTY
				GROUP 04: BOOM POSITION SUPPORT ASSEMBLY	
				FIG. C-14. MECHANICAL STOP ASSY	
	PAFDD	82402	42305E540	MECHANICAL STOP ASSY (SEE FIG. C-11 FOR NHA)	REF
1	PADZZ	83553	C0240-024-0500S	. DOWEL	3
2	PADZZ	82402	42305D545	. GEAR, IDLER	1
3	PADZZ	60380	B44XOH	. BEARING, NEEDLE	1
4	PADZZ	82402	42277D544	. DRIVER, GEAR	1
	ADDDD	82402	42305E562	. GEAR/STOP ASSY	1
5	PADZZ	82402	42305D563	. . GEAR, DRIVEN	1
6	PADZZ	82402	42305D547	. . GEAR/STOP ASSY	1
7	PADZZ	82402	42305D564	. . CAM, SLOTTED	1
8	PADZZ	96906	MS20426DD2-8	. . RIVET	4
9	PADZZ	82402	42277D550	. SPACER, PAWL	1
10	PADZZ	82402	42277D551	. STOP, PAWL	1
11	PADZZ	82402	42277C546	. RETAINER	1
12	PADZZ	96906	MS24693-24	. SCREW	1
13	PADZZ	83553	C0240-024-0500S	. SPRING	2
14	PADZZ	82402	42305E552	. COUPLING, DRIVER SLOT	1
15	XADZZ	82402	42277E542	. HOUSING	1
				END OF FIGURE	

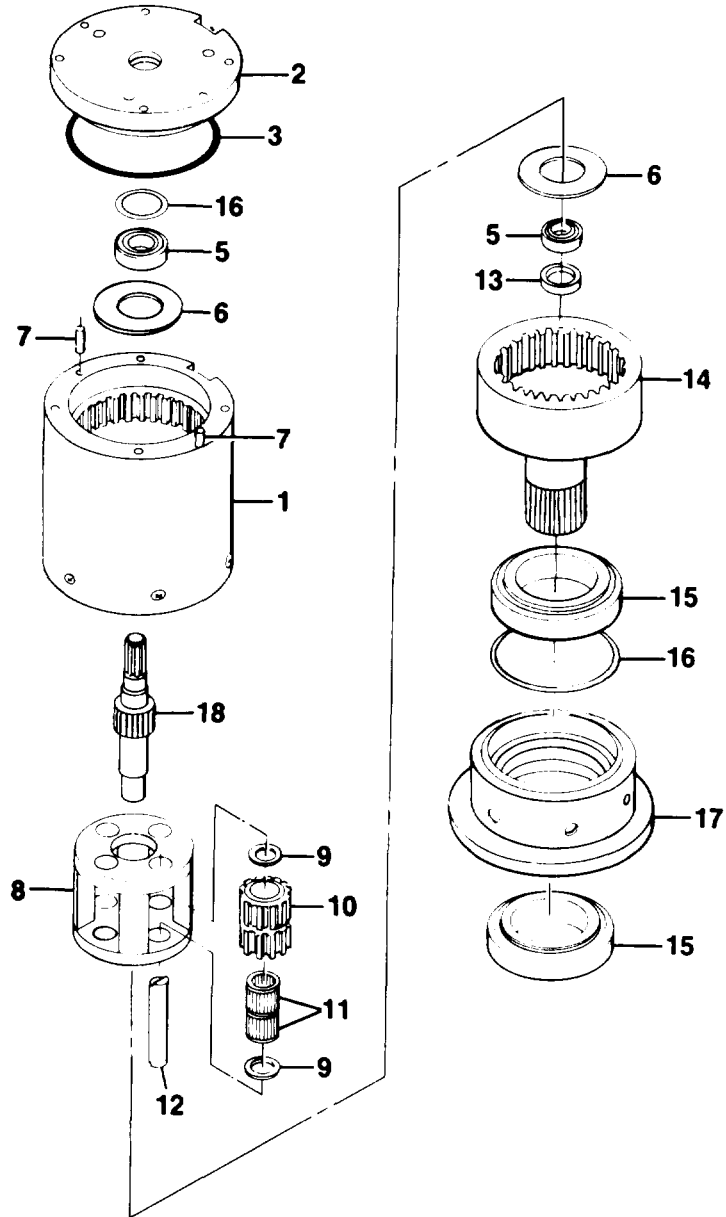


FIGURE C-15. ROTARY ACTUATOR ASSY

(1) ITEM NO.	(2) SMR CODE	(3) FSCM	(4) PART NUMBER	TM 55-1680-320-23&P (5) DESCRIPTION AND USABLE ON CODE (UOC)	(6) QTY
GROUP 04: BOOM POSITION SUPPORT ASSEMBLY					
FIG.C-15 ROTARY ACTUATOR ASSY					
	PADDD	82402	42305E555	ROTARY ACTUATORY ASSY (SEE FIG. C-11 FOR NHA)	REF
1	XDDZZ	82402	42277E556	HOUSING RING GEAR	1
2	PADZZ	82402	42277D557	COVER-HOUSING, TOP	1
3	PADZZ	81343	AS568-035MILG21 569C6	PACKING, PREFORMED	1
4	PADZZ	82402	1706B59	SHIM	1
5	PADZZ	38443	R6ZZST035T023H20	BEARING, BALL	2
6	PADZZ	97820	T087-1A	WASHER, THRUST	2
7	PADZZ	56878	28420-156A8	PIN, STRAIGHT	2
8	PADZZ	82402	42217D89	CARRIER, PLANETARY INPUT	1
9	PADZZ	82402	42217C93	WASHER, THRUST	8
10	PADZZ	82402	42217D87	GEAR, SPUR-PLANET	4
11	PADZZ	21366	K10X13X13TN	BEARING, NEEDLE	8
12	XDDZZ	82402	42217C88	PIN, PLANETARY CARRIER	4
13	PADZZ	96879	B40-24-2	SEAL	1
14	PADZZ	82402	42305E502	GEARSHAFT, OUTPUT	1
15	PADZZ	96906	MS27641-20	BEARING, BALL	2
16	PADZZ	82402	49003C10	SHIM	1
17	XDDZZ	82402	42305E558	COVER-HOUSING, BOOM	1
18	PADZZ	82402	42277E559	SHAFT, SUN GEAR INPUT STUB	1

END OF FIGURE

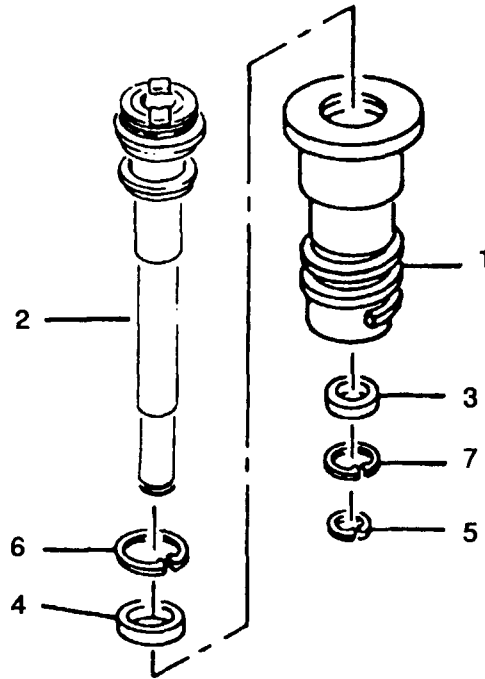


FIGURE C-16. HEIGHT ADJUSTER ASSY

(1) ITEM NO.	(2) SMR CODE	(3) FSCM	(4) PART NUMBER	DESCRIPTION AND USABLE ON CODE(UOC)	(6) QTY
				GROUP 0401: HEIGHT ADJUSTER ASSEMBLY	
				FIG. C-16. HEIGHT ADJUSTER	
				HEIGHT ADJUSTER ASSEMBLY	REF
				(SEE FIG. C-n FOR NHA)	
1	XDOZZ	82402	42305E526	.sHAFr	1
2	PAOZZ	82402	42305E581	. ADAPTER	1
3	PAOZZ	%906	MS27646-38	. BEARING	1
4	PAOZZ	%906	MS27646-39G	. BEARING	1
5	PAOZZ	98349	RST62	. RING, RELINING....	1
6	PAOZZ	80756	RRT118	. RING, RETAININ	1
7	PAOZZ	80756	RRT106CK	. RING, RETAINING	1
				END OF FIGURE	

**THIS PAGE
INTENTIONALLY
LEFT BLANK**

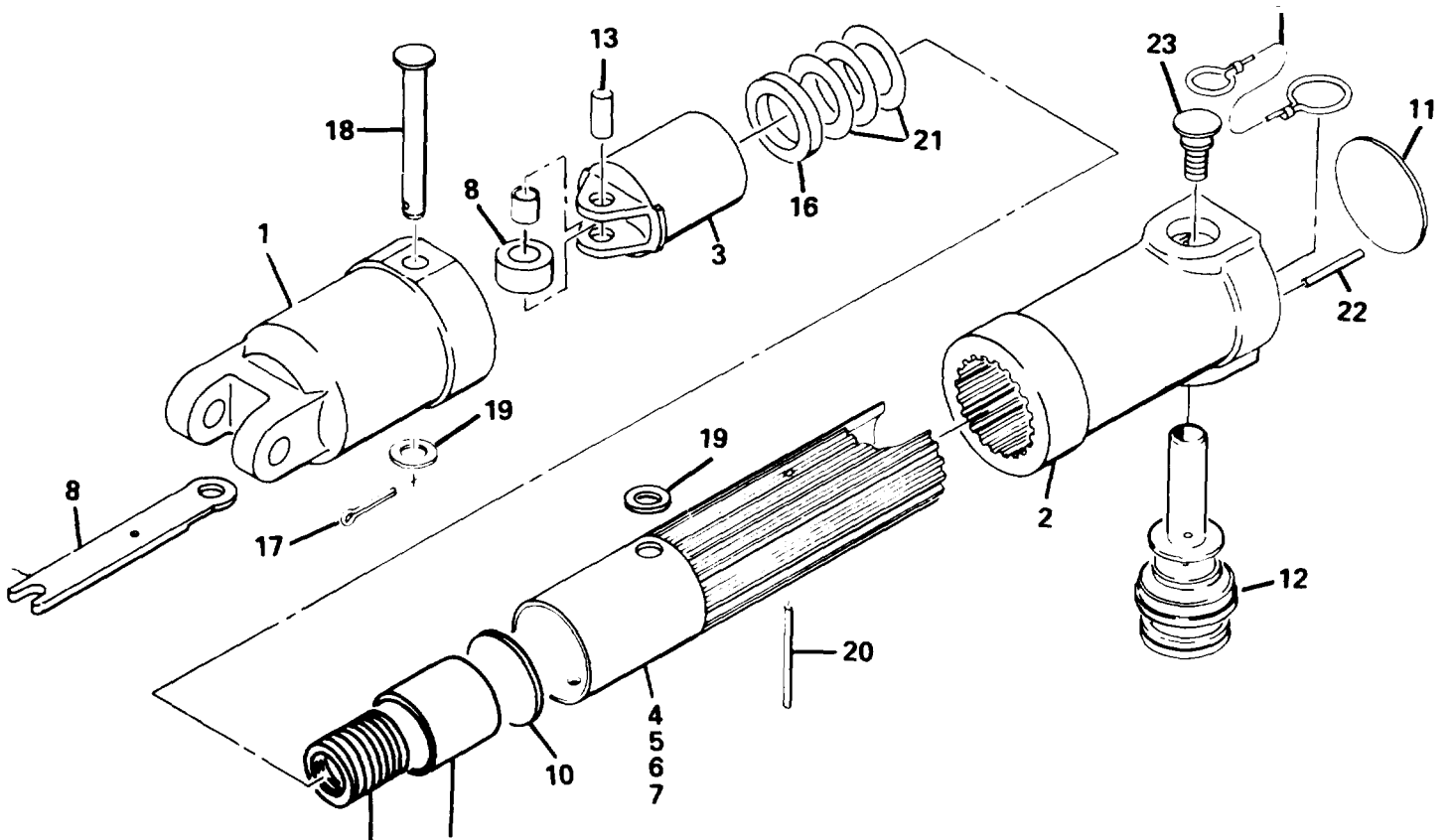


FIGURE C-17. REACTION ARM ASSY

TM 55-1680-320-23&P

(1)	(2)	(3)	(4)	(5)	(6)
ITEM	SMR		PART	DESCRIPTION	
NO.	CODE	FSCM	NUMBER	AND USABLE ON CODE (UOC)	QTY

GROUP 0404: REACTION ARM
ASSEMBLY

FIG. C-17 REACTION ARM ASSY

					REF
	PAODD	82402	42305E510	REACTION ARM ASSY (SEEFIG. C-11 FOR NHA)	
1	PADZZ	82402	42305E511	REACTION ARM	1
2	PBDDD	82402	42305E512	EXTENSION ARM	1
3	PADZZ	82402	42277E513	TUBE,ROLLER	1
4	PADDD	82402	42305E514	ARM,PIVOT	1
5	XDDDD	82402	42305E514-1	ARM,PIVOT	1
6	XDDDD	82402	42277D516	ARM,OVERLOAD	1
7	PADZZ	96906	MS20427F4-5	RIVET	1
8	PADZZ	82402	42277D607	CAM ASSY,ROLLER	1
9	PAOZZ	82402	42277C517	LANYARD,EXTENSION	1
10	PADZZ	82402	42277C518	WASHER,SPRING REACTION	1
11	PAOZZ	96906	MS35648-12	CPA,EXTENSION ARM	1
12	PAOZZ	82402	42305E561	ADAPTER,QUICK DISCONNECT	1
13	PADZZ	82402	42277C576	ROLLER	1
14	PADZZ	82402	42305C515	GUIDE,CUP-SPRING	1
15	PADZZ	82402	42305D608	SPRING	1
16	PADZZ	82402	42277C584	SPACER	1
17	PADZZ	96906	MS24665-283	PIN,COTTER	1
18	PADZZ	96906	MS20392-5C71	PIN,CLEVIS	1
19	PADZZ	88044	AN960PD616	WASHER	2
20	PADZZ	96906	MS9048-112	PIN	1
21	PADZZ	88044	AN960-1016L	WASHER	3
22	PAOZZ	96906	MS16562-36	PIN-SPRING,CAP	1
23	PAOZZ	82402	42305D569	STUD	1

END OF FIGURE

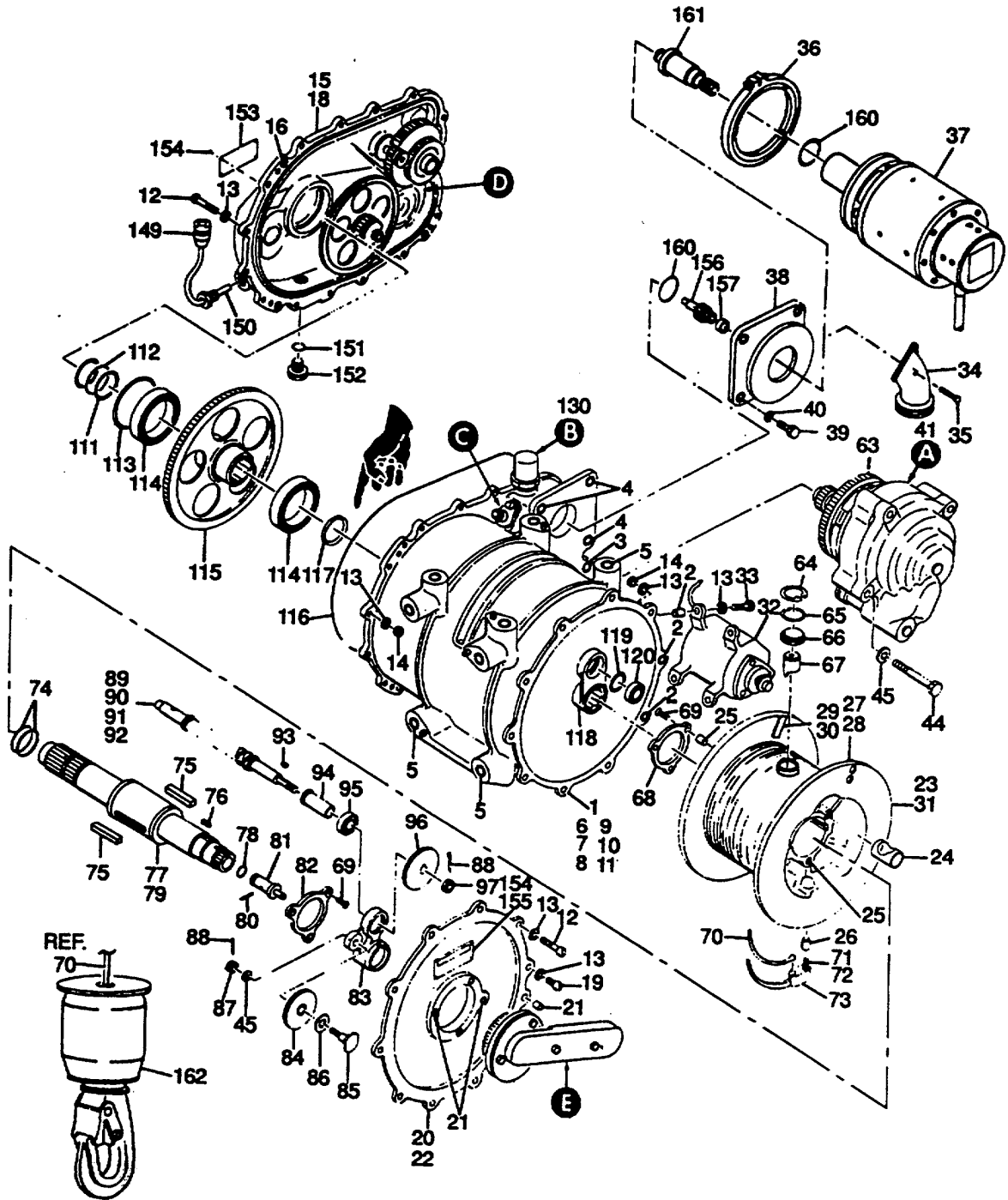


FIGURE C-18. WINCH ASSY (SHEET 1 OF 3)

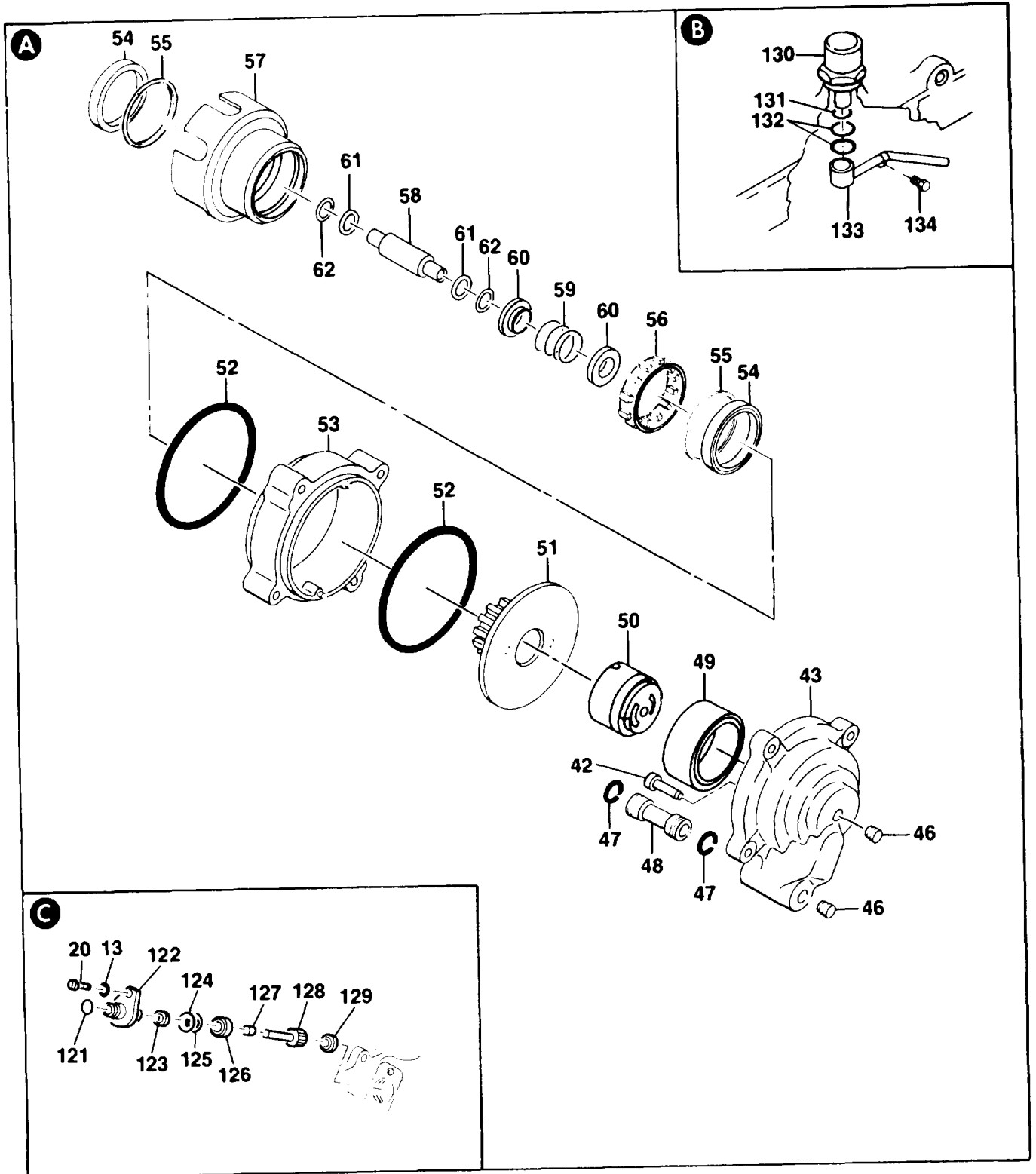


FIGURE C-18. WINCH ASSY (SHEET 2 OF 3)

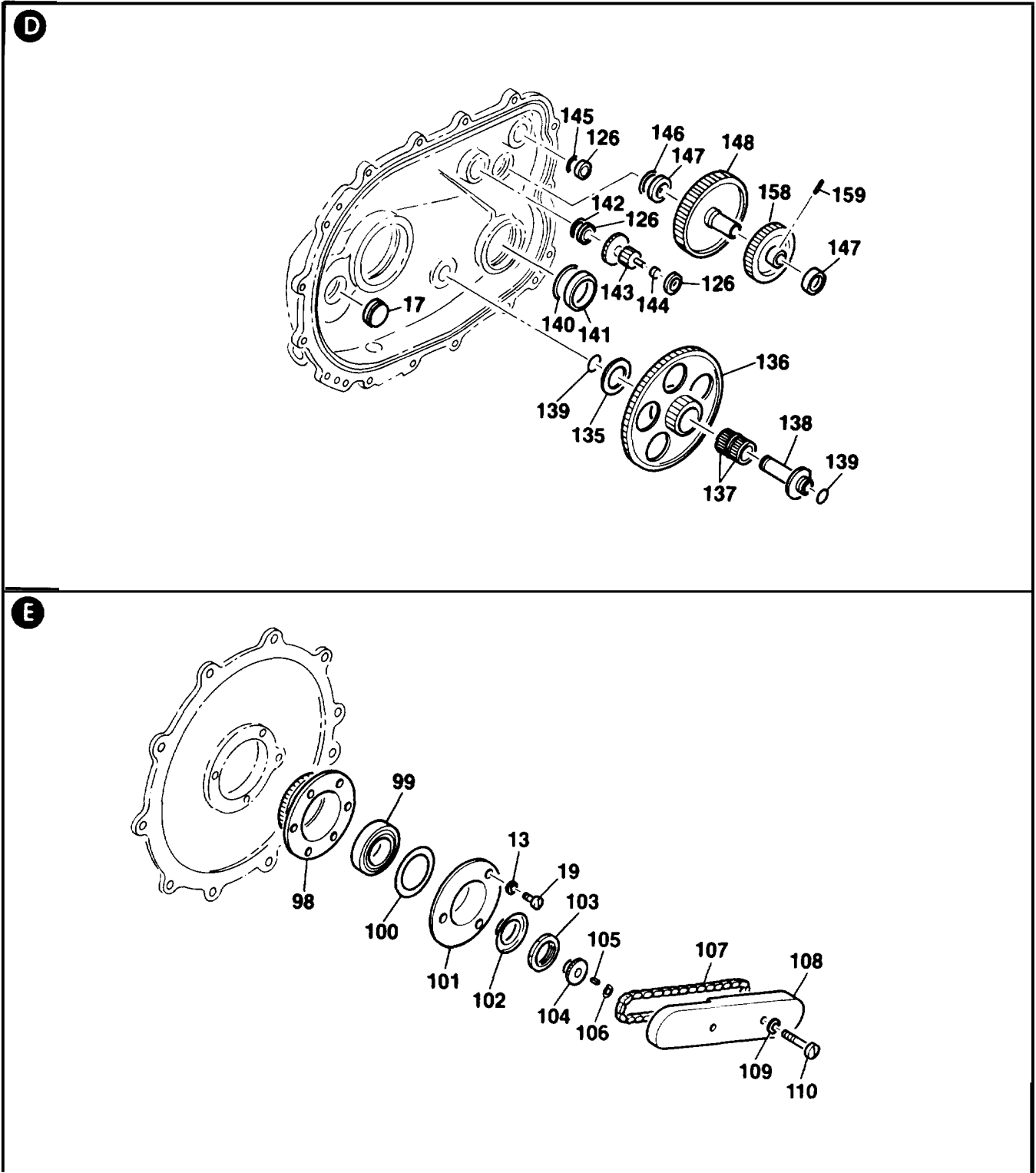


FIGURE C-18. WINCH ASSY (SHEET 3 OF 3)

(1) ITEM NO.	(2) SMR CODE	(3) FSCM	(4) PART NUMBER	(5) DESCRIPTION AND USABLE ON CODE (UOC)	(6) QTY
GROUP 05: WINCH ASSEMBLY					
FIG.C-18. WINCH ASSY					
	PAFDD	82402	42305R100	WINCH ASSY (SEE FIG. C-1 FOR NHA)	REF
1	PBDDD	82402	42277R110	HOUSING ASSY,MAIN	1
2	PADZZ	80205	NAS1394C3L	INSERT	7
3	PADZZ	80205	NAS1394C4L	INSERT	4
4	PBDZZ	80205	NAS1394C5L	INSERT	4
5	PADZZ	96906	MS51830-204L	INSERT	12
6	PAFZZ	80205	NAS1395C06	INSERT	1
7	PAFZZ	96906	MS16555-20	PIN,DOWEL	1
8	PAFZZ	96906	MS16555-40	PIN,DOWEL	1
9	PAFZZ	96906	MS16555-55	PIN,DOWEL	3
10	PAFZZ	96906	MS16555-60	PIN,DOWEL	6
11	XADDD	82402	42277R110-1	HOUSING	1
12	PADZZ	96906	MS35266-66	SCREW	23
13	PADZZ	88044	AN960PD10	WASHER, FLAT	57
14	PADZZ	96906	MS21083N3	NUT, SELF-LOCK	23
15	PBDDD	82402	42277R111	COVER ASSY,GEARBOX	1
16	PBDZZ	80205	NAS1394CA3	INSERT	3
17	PADZZ	70925	B5631	WINDOW, SIGHT	1
18	XADDD	82402	42277R111-1	COVER	1
19	PAOZZ	96906	MS35266-65	SCREW	5
20	PAOZZ	82402	42277E112	COVER ASSY,DRUM	1
21	PAFZZ	80205	NAS1394C3	INSERT	5
22	XAFZZ	82402	42277E112-1	COVER	1
23	PBODD	82402	42277R115	DRUM ASSY,CABLE	1
24	XDFZZ	70417	AA921-3	BEARING	1
25	PADZZ	96906	MS51830-202	INSERT	6
26	PADZZ	80205	NAS1394C3L	INSERT	1
27	PBDZZ	82402	42234D85	CASTING,KICKER CABLE	4
28	PADZZ	80205	NAS620-8	WASHER, FLAT	1
29	PADZZ	96906	MS17795-103	BUSHING	1
30	PADZZ	80205	NAS620-8	WASHER, FLAT	1
31	XADDD	82402	42234R182-1	DRUM	1
32	PAOFF	82402	42305R220	LIMIT SWITCH DRIVE ASSY (SEE FIG. C-21 FOR BREAKDOWN)	1
33	PAOZZ	96906	MS16998-29	BOLT	3
34	PAOZZ	82402	42305E143	AIRDUCT,HOIST MOTOR	1
35	POAZZ	88044	AN3-25A	SCREW	1
36	PAOZZ	98628	MV83523TS446V	COUPLING	1
37	PAODD	82402	527KE3	MOTOR,ELECTRIC (SEE FIG. C-19 FOR BREAKDOWN)	1
38	XDFZZ	82402	42305R142	ADAPTER ASSY	1
39	PAFZZ	88044	AN5H6	SCREW	4
40	PAFZZ	88044	AN960PD516	WASHER	8

(1) ITEM NO.	(2) SMR CODE	(3) FSCM	(4) PART NUMBER	(5) DESCRIPTION AND USABLE ON CODE (UOC)	(6) QTY
41	XDFFF	82402	42305R113	PUMP HOUSING ASSY	1
42	PADZZ	82402	42305C114	PIN,DOWEL	1
43	XAFZZ	82402	42305R113-1	HOUSING	1
44	PAFZZ	80205	NAS1304-18	SCREW	4
45	PAFZZ	88044	AN960PD416	WASHER,FLAT	5
46	PAFZZ	96906	MS27769-2	PLUG,PIPE	2
47	PAFZZ	02697	2-111V747-75	PACKING,PREFORMED	2
48	PAFZZ	82402	42277C214	TUBE,OIL TRANSFER	1
49	PAFZZ	80657	J2816	BEARING,BALL	1
50	PAFZZ	82402	42305E213	PUMP ASSY,BRAKE COOLING	1
51	PBFZZ	82402	42277D217	SHAFT ASSY,SPRAG REACTION	1
52	PAFZZ	80205	NAS1593-152	PACKING,PREFORMED	2
53	PAFZZ	82402	42277E210	HOUSING,BRAKE	1
54	PAFZZ	38443	B543	BEARING,BALL	2
55	PAFZZ	82402	42277C216	SPACER,SPRAY AUTO BRAKE	2
56	PBFZZ	82402	42234D178	SPRAG CLUTCH ASSY	1
57	PBFZZ	82402	42277E206	CUP,BRAKE,DISC AUTO BRAKE	1
58	PBFZZ	82402	42305D211	SHAFT,PUMP DRIVE	1
59	PAFZZ	92208	B21139	SPRING	1
60	PAFZZ	82402	42305C148	SLEEVE	2
61	PAFZZ	81349	M83248-1-011	PACKING	2
62	PAFZZ	96906	MS28774-011	RETAINER	2
63	PAFZZ	82402	42305E200	AUTOMATIC BRAKE ASSY (SEE FIG. C-22 FOR BREAKDOWN)	1
64	PAOZZ	96906	MS16625-1090	RING,RETAINING INT	1
65	PAOZZ	82402	1700B67	SHIM	1
66	XDOZZ	82402	42234D54	RETAINER-SHOE,LEVEL WIND	1
67	PAOZZ	82402	42234D167	SHOE,LEVEL WIND	1
68	PBDZZ	82402	42234D52	PLATE,RACE RETAINER	1
69	PADZZ	96906	MS24693C295	SCREW	6
70	PAOZZ	82402	42305D179	CABLE	1
71	PAOZZ	82402	42234D97	SCREW,FINGER RETAINER	1
72	XDOZZ	07236	WA510	RING,RETAINING	1
73	PAOZZ	82402	42234E56	FINGER,CABLE,RET DR	1
74	PADZZ	82402	42234D65	RING,RETAINING LEVEL WIND DR	2
75	PADZZ	96906	MS20066-234	KEY,MACH	2
76	PADZZ	96906	MS20068-53	KEY,SQUARE	1
77	PADDD	82402	42277E180	BALL SPLINE ASSEMBLY,DRUM DR	1
78	PADZZ	81349	M83248-1-014	PACKING	1
79	XADDD	82402	42277E118	BALL SPLINE	1
80	PADZZ	96906	MS51838-93	PIN,STRAIGHT	1
81	PADZZ	82402	42277D181	ADAPTER,SPROCKET	1
82	PADZZ	82402	42234D52	PLATE,RACE RETAINER	1
83	PADZZ	82402	42277E184	ARM,GEAR LEVEL	1
84	PADZZ	82402	42277D131	GEAR,CLUSTER	1
85	PADZZ	82402	42234D179	SHAFT,CLUSTER GEAR	1
86	PADZZ	09455	LTD0714	WASHER,THRUST	1

TM 55-1680-320-23&P

(1) ITEM NO.	(2) SMR CODE	(3) FSCM	(4) PART NUMBER	(5) DESCRIPTION AND USABLE ON CODE (UOC)	(6) QTY
87	PADZZ	88044	AN320-4	. NUT, CASTLE SHEAR	1
88	PAFZZ	96906	MS24665-134	. PIN, COTTER	2
89	PADDD	82402	42277D137	. SCREW ASSY, LEVEL WIND.	1
90	XADZZ	82402	42277E138	. . SCREW	1
91	PBDZZ	82402	42277D139	. . SPACER	1
92	PADZZ	96906	MS20613-4C14	. . RIVET	1
93	PADZZ	96906	MS9841-06	. KEY, WOODRUFF	1
94	PBDZZ	82402	42277D139	. SPACER	1
95	PADZZ	38443	R8ZZ	. BEARING, BALL	1
96	PBDZZ	82402	42277D130	. GEAR, OUTPUT	1
97	PADZZ	88044	AN320-5	. NUT, CASTLE SHEAR	1
98	PBDZZ	82402	42277E125	. GEAR, STATIONARY	1
99	PADZZ	21335	9105KPP	. BEARING, BALL	1
100	PBDZZ	81349	MILS22499	. SHIM	V
101	PBDZZ	82402	42277D124	. RETAINER, BEARING	1
102	PADZZ	96906	MS172206	. WASHER	1
103	PADZZ	96906	MS172241	. NUT, SPANNER	1
104	PAFZZ	82402	42277D156	. SPROCKET, CHAIN	1
105	PAFZZ	82402	49008C3	. KEY, SQUARE	1
106	PAFZZ	96906	MS16624-1025	. RING, RETAINING	1
107	PAOZZ	82402	42277C175	. ROLLER CHAIN	1
108	PBOZZ	82402	42277E168	. GUARD, CHAIN	1
109	PAOZZ	96906	MS14151-2	. WASHER, FLAT	1
110	PAOZZ	96906	MS35207-268	. SCREW	1
111	PADZZ	96906	MS28782-20	. RING, BACKUP	2
112	PADZZ	81349	M83248/1-215	. PACKING, PREFORMED	1
113	PBDZZ	82402	49001C82	. SHIM	V
114	PADZZ	38448	1908S	. BEARING, BALL	2
115	XDDZZ	82402	42277E117	. GEAR, DRUM DRIVE	1
116	PADZZ	81349	M83248/1-278	. PACKING, PREFORMED	1
117	PADZZ	82402	42277C244	. SEAL, OIL	1
118	PBDZZ	82402	42277E183	. ARM, LEVEL WIND	1
119	PBDZZ	82402	49001C12	. SHIM	1
120	PADZZ	38443	R8ZZ	. BEARING, BALL	1
121	PADZZ	80205	NAS1593-013	. PACKING, PREFORMED	1
122	PBDZZ	82402	42277D167	. ADAPTER, FLEX SHAFT	1
123	PADZZ	73680	71X7000	. SEAL, OIL	1
124	PADZZ	81349	M83248-1-016	. PACKING, PREFORMED	1
125	PAFZZ	82402	49001C8	. SHIM	1
126	PADZZ	38443	R4A4ST0305A023H 10X7296L	. BEARING, BALL	4
127	PADZZ	82402	42277C195	. SPACER, HELICAL GEAR.	1
128	PBFZZ	82402	42277E166	. GEARSHAFT ASSY	1
129	PADZZ	21335	AMS1K7	. BEARING, BALL	1
130	PBOZZ	82402	42305D119	. BREATHER ASSY	1
131	PAOZZ	80205	NAS1595-8	.PACKING,PREFORMED	1
132	PAOZZ	81349	M83248-1-905	.PACKING,PREFORMED	2

TM 55-1680-320-23&P

(1) ITEM NO.	(2) SMR CODE	(3) FSCM	(4) PART NUMBER	(5) DESCRIPTION AND USABLE ON CODE (UOC)	(6) QTY
133	PADZZ	82402	42305E127	. BREATHER TUBE ASSY.....	1
134	PADZZ	88044	AN503-6-12	. SCREW	1
135	PADZZ	09455	LTD1020	. WASHER, THRUST	1
136	XDDZZ	82402	42277E198	. GEAR, CLUSTER	1
137	PADZZ	60380	J108	. BEARING, ROLLER	2
138	XDDZZ	82402	42277D121	. SHAFT, FIXED	1
139	PADZZ	81349	M83248-1-014	. PACKING, PREFORMED.	2
140	PBDZZ	82402	49001C82	. SHIM	1
141	PADZZ	21335	9306K	. BEARING, BALL	1
142	PAFZZ	82402	49001C8	. SHIM	1
143	PADZZ	82402	42277D165	. GEARSHAFT ASSEMBLY	1
144	PAFZZ	82402	42277C150	. SPACER	2
145	PAFZZ	82402	49001C8	. SHIM	1
146	PADZZ	82402	49001C36	. SHIM	1
147	PADZZ	38443	1902S	. BEARING, BALL	2
148	PBDZZ	82402	42305E222	. GEARSHAFT IDLER	1
149	PAOOO	77820	PC06E8-4SSR	. PLUG, CONNECTING	1
150	PAOZZ	82402	42277D179	. SWITCH, THERMAL	1
151	PAOZZ	80205	NAS1595-8	. PACKING, PREFORMED.	1
152	PAOZZ	96906	MS9015-08	. PLUG	1
153	XDDZZ	82402	42277C221	. PLATE, LUBRICATION	1
154	PADZZ	96906	MS21318-7	. SCREW, DRIVE	8
155	PBDZZ	82402	42305C173	. PLATE, IDENTIFICATION	1
156	PBDZZ	82402	42305D128	. PINION, INPUT DRIVE	1
157	PADZZ	38443	1903S	. BEARING, BALL	1
158	PBDZZ	82402	42305E159	. GEAR, IDLER FIRST STAGE..	1
159	PADZZ	96906	MS35756-3	. KEY, WOODRUFF	1
160	PAOZZ	80205	NAS1593-133	. PACKING	2
161	PBODD	82402	42305E132	. INERTIA DUMP ASSY (SEE FIG. C-20 FOR BREAKDOWN)	1
162	PAOOO	82402	42305E280	. CABLE HOOK ASSY (SEE FIG. C-23 FOR BREAKDOWN)	1
END OF FIGURE					

**THIS PAGE
INTENTIONALLY
LEFT BLANK**

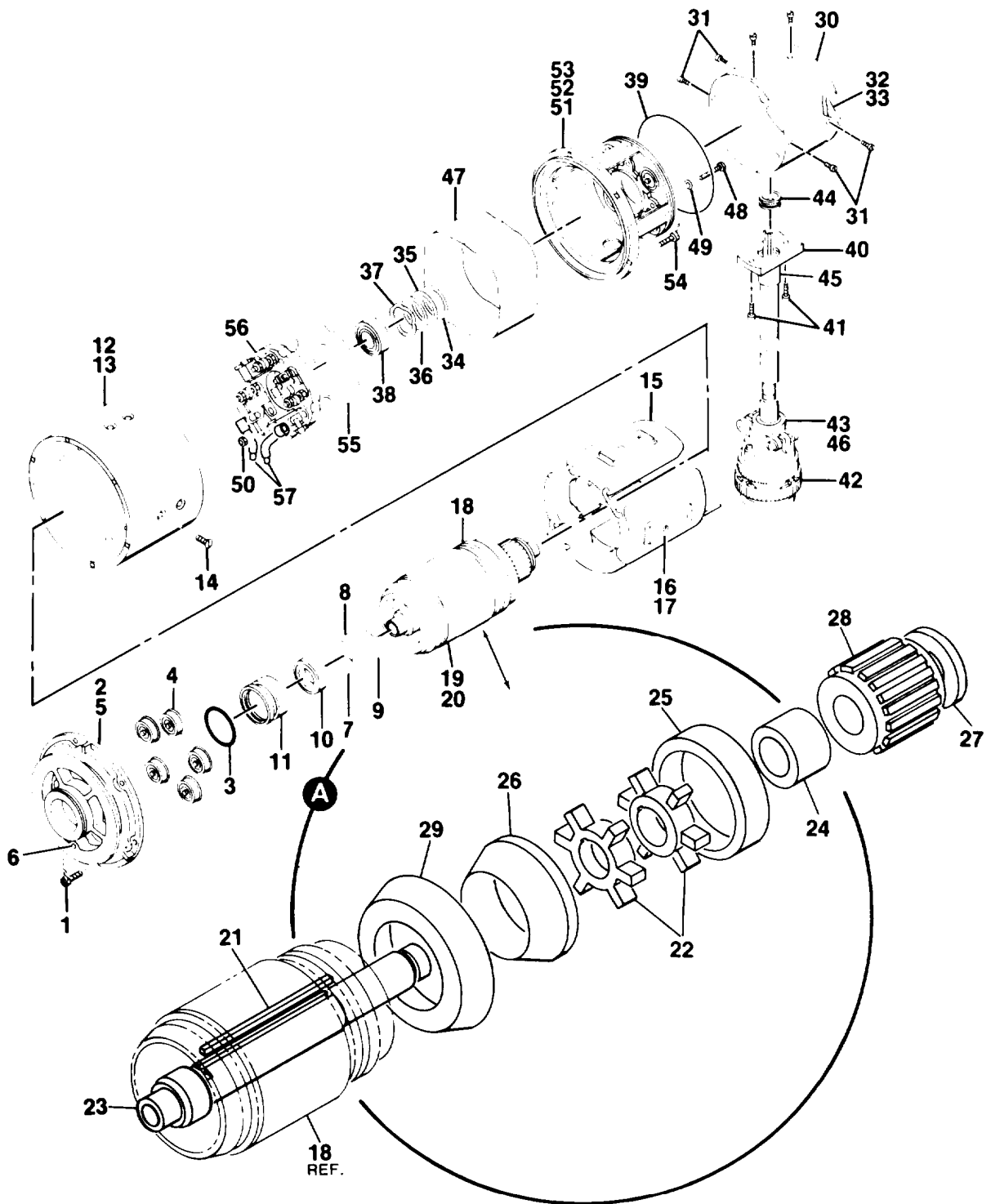


FIGURE C-19. ELECTRIC MOTOR

(1) ITEM NO.	(2) SMR CODE	(3) FSCM	(4) PART NUMBER	(5) DESCRIPTION AND USABLE ON CODE (UOC)	(6) QTY
				GROUP 0501: MOTOR	
				FIG. C-19, ELECTRIC MOTOR	
				MOTOR, ELECTRIC (SEE FIG. C-18 FOR NHA) .	REF
1	PAODD	82402	527KE3	.SCREW	6
2	PADZZ	96906	MS24678-11	.END BELL ASSY, FRONT	1
3	XDDDD	82402	149101	. . PACKING	1
4	PADZZ	96906	MS28775-126	. . BREATHER, FLAME ARRESTING	5
5	PADZZ	82402	80177	. . ENDBELL	1
6	XDDZZ	82402	149102	. . INSERT	1
7	XADZZ	82402	149104	.SHIM	v
8	PADZZ	82402	886-167	.SHIM	v
9	PADZZ	82402	886-168	.SHIM	v
10	PADZZ	82402	886-169	.SHIM	v
11	PADZZ	43334	Z993L03XR1DU4	.BEARING, BALL	1
12	PADZZ	91340	D14131-6	.SEAL	1
13	ADDDD	82402	21877	. YOKE ASSEMBLY	1
14	XDDZZ	82402	149106	. . HOUSING, MOTOR	1
15	PADZZ	88044	AN505-10-9	. . SCREW	8
16	XDDZZ	82402	21811	. . FIELD COIL ASSY	1
17	XDDZZ	82402	21812	. . POLE PIECE ASSY	4
18	XDDZZ	82402	80200-2	. . FUSE, THERMAL	1
19	PADDD	00462	36786	. ARMATURE ASSY	1
20	XDDZZ	82402	145025	. . INSULATION, SHEET	v
21	XDDZZ	82402	146778	. . INSULATION, SHEET	v
22	XDDZZ	82402	13561-23	. . KEY	1
23	XDDZZ	82402	36410	. . FAN	2
24	XADZZ	82402	36787	. . SHAFT, MOTOR	1
25	XDDZZ	82402	36609	. . SPACER	1
26	XDDZZ	82402	36610-1	. . SUPPORT	1
27	XDDZZ	82402	36346	. . SUPPORT	1
28	XDDZZ	82402	36611	. . SLEEVE	1
29	XDDZZ	82402	80181-2	. . COMMUTER	1
30	XDDZZ	82402	145865	. . WIRE	v
31	PBDZZ	82402	19777	.SHROUD, MOTOR	1
32	PADZZ	96906	MS35265-26	.SCREW	6
33	XDDZZ	82402	149105	.PLATE, IDENTIFICATION	1
34	PADZZ	81349	M24243/1-A302	. POP-RIVET	4
35	XDDZZ	82402	886-249	.SHIM	v
36	XDDZZ	82402	886-250	.SHIM	v
37	PADZZ	82402	886-251	.SHIM	v
38	PADZZ	82829	16BS100C7	.WASHER, WAVY SPRING...	1
39	PADZZ	82402	80192	.BEARING, BALL	1
40	PADZZ	96906	MS9068-044	. PACKING	1
41	PADZZ	82402	19781	.PLATE, ADAPTER	1
42	PAOZZ	96906	MS21090-0623	.SCREW	2
	PAOZZ	82402	19948	.CONNECTOR ASSY	1

TM 55-1680-320-23&P

(1) ITEM NO.	(2) SMR CODE	(3) FSCM	(4) PART NUMBER	(5) DESCRIPTION AND USABLE ON CODE (UOC)	(6) QTY
43	XADZZ	96906	MS3420-16	. BUSHING, TELESCOPING	1
44	PADZZ	03296	G60T-C10	. GROMMET	1
45	PADZZ	82402	19693	. TUBULAR BRAID ASSY	1
46	PADZZ	82402	19695	. TUBULAR BRAID ASSY	1
47	PBDZZ	82402	19776	. INSULATOR	1
48	PADZZ	96906	MS35206-234	. SCREW	4
49	PADZZ	88044	AN960-6	. WASHER	4
50	PADZZ	96906	MS21083N06	. NUT	4
51	XDDDD	82402	19773	. END BELL & BREATHER ASSY	1
52	XADDD	82402	19774	. . ENDBELL ASSY	1
53	PADZZ	82402	80177	. . BREATHER, FLAME ARRESTING	4
54	PADZZ	96906	MS24678-11	. SCREW	6
55	PADZZ	82402	14853	. INSULATOR, BRUSH HOLDER	1
56	XBDZZ	82402	149110	. BRUSHHOLDER AND PROTECTOR ASSY	1
57	XDDZZ	82402	19775	. CABLE	V
END OF FIGURE					

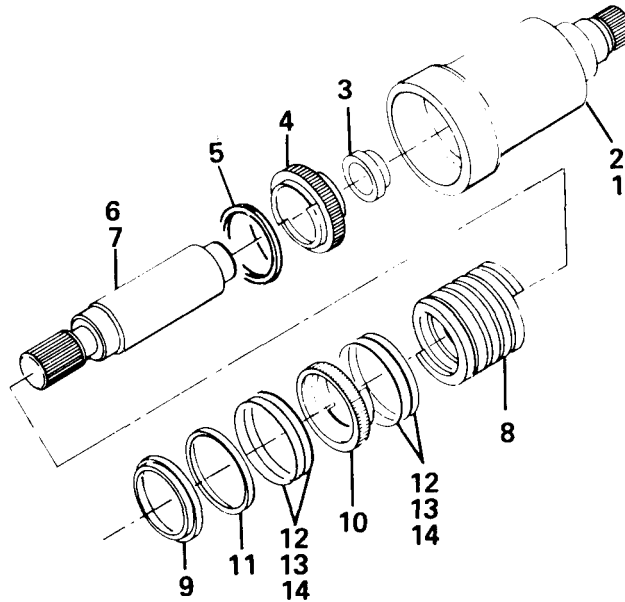


FIGURE C-20. INERTIA DUMP ASSEMBLY

(1) ITEM NO.	(2) SMR CODE	(3) FSCM	(4) PART NUMBER	(5) DESCRIPTION AND USABLE ON CODE (UOC)	(6) QTY
				GROUP 0502: INERTIA DUMP ASSEMBLY	
				FIG. C-20. INERTIA DUMP ASSY	
	PBODD	82402	42305E132	INERTIA DUMP ASSY (SEE FIG. C-18 FOR NHA)	REF
1	PBDDD	82402	42305E237	. DRIVER ASSY, SPLICED	1
2	XADZZ	82402	42305E237-1	. .DRIVER, SPLINED	1
3	PADZZ	82402	42305C234	. . BEARING, FLANGED	1
4	PADZZ	82402	42305D235	. . DOG, STOP	1
5	PADZZ	82402	42305C243	. . WASHER	1
6	PADZZ	82402	42305D232	. CLUTCH, SHAFT ASSY	1
7	XADZZ	82402	42305D230	. . SHAFT, CLUTCH	1
8	PADZZ	82402	42305D231	. . SPRING, CLUTCH	1
9	PADZZ	82402	42305D238	. SPACER, LOCK	1
10	PADZZ	82402	42305E236	. DOG STOP ASSY	1
11	PADZZ	80756	MILR27426	. RING, RETAINING	1
12	PADZZ	82402	886-360	. . SHIM	3
13	PADZZ	82402	886-361	. . SHIM	2
14	PADZZ	82402	886-362	. . SHIM	3
				END OF FIGURE	

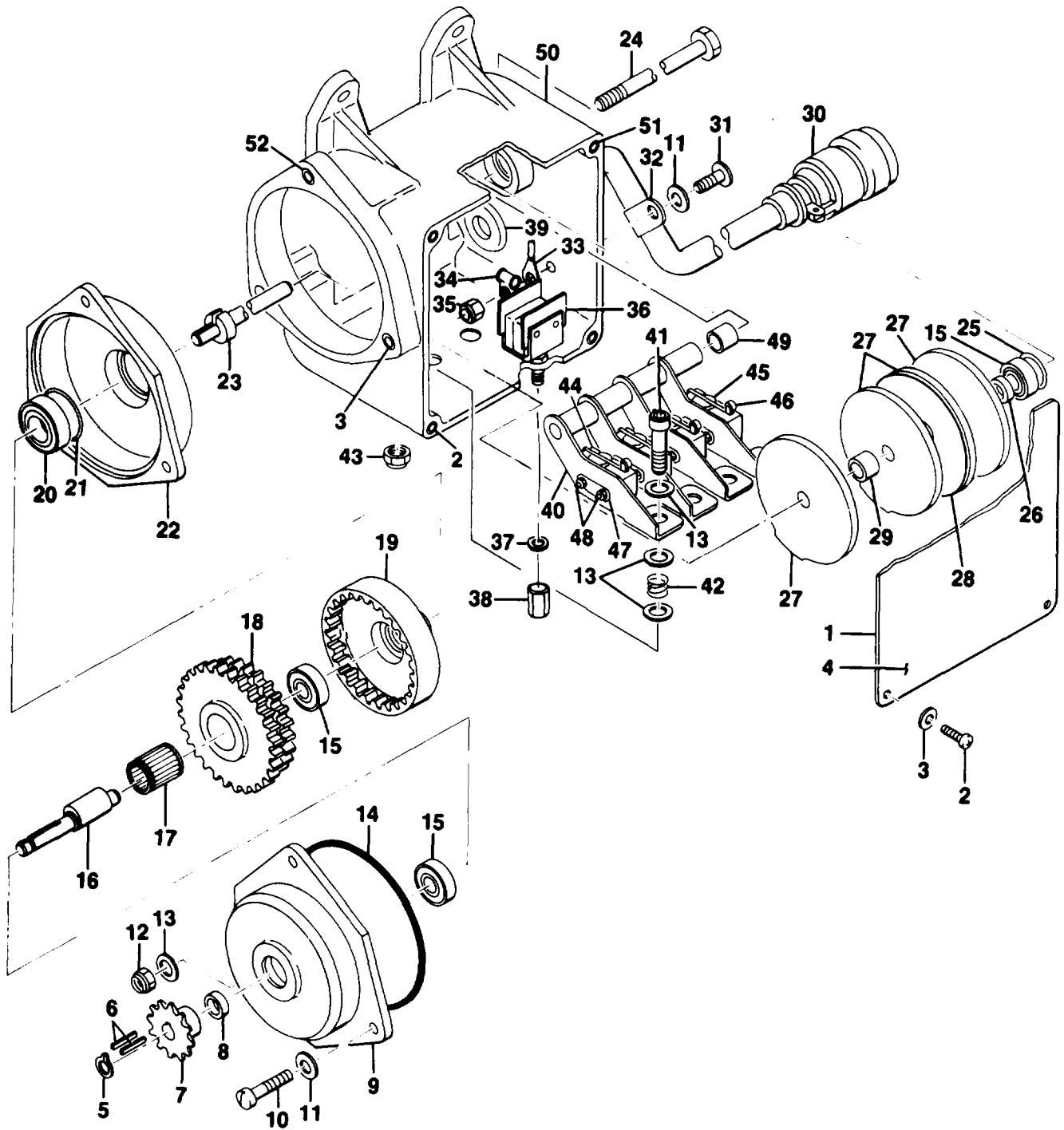


FIGURE C-21. LIMIT SWITCH DRIVE ASSY

TM 55-1680-320-23&P

(1) ITEM NO.	(2) SMR CODE	(3) FSCM	(4) PART NUMBER	(5) DESCRIPTION AND USABLE ON CODE (UOC)	(6) QTY
				GROUP 0503: LIMIT SWITCH DRIVE ASSEMBLY	
				FIG. C-21. LIMIT SWITCH DRIVE ASSY	
	PAOFF	82402	42305R220	LIMIT SWITCH DRIVE ASSY (SEE FIG. C-18 . . . FOR NHA)	REF
1	PBOZZ	82402	42277D153	. COVER, LIMIT SWITCH BOX	1
2	PAFZZ	96906	MS16997-18	. SCREW	4
3	PAFZZ	88044	AN960PD6	. WASHER	4
4	XDFZZ	82402	42305E225	. PLATE, INSTRUCTION	1
5	PAFZZ	96906	MS16624-1025	. RING, RETAINING	1
6	PAFZZ	82402	49008C3	. KEY, SQUARE	2
7	PAFZZ	82402	42277D156	. SPROCKET, CHAIN	1
8	PAFZZ	82402	42277C155	. SPACER, SPROCKET	1
9	PBFZZ	82402	42277E145	. GEAR, INT. LIMIT SWITCH DRIVE	1
10	PAFZZ	96906	MS35265-46	. SCREW	2
11	PAFZZ	88044	AN960PD8	. WASHER, FLAT	3
12	PAFZZ	96906	MS21083D3	. NUT, SELF-LOCK	1
13	PAFZZ	88044	AN960PD10L	. WASHER, FLAT	13
14	PAFZZ	81349	M83248-1-035	. PACKING, PREFORMED	1
15	PAFZZ	38443	R4ZZ	. BEARING, BALL	3
16	PBFZZ	82402	42277D140	. SHAFT, LIMIT SWITCH DRIVE	1
17	PBFZZ	60380	J68OH	. BEARING, NEEDLE	1
18	PBFZZ	82402	42277D223	. GEAR, CLUSTER LIMIT SWITCH DRIVE	1
19	PBFZZ	82402	42277E144	. GEAR, INT. LIMIT SWITCH DRIVE	1
20	PAFZZ	38443	R6ZZST03S- T023H20	. BEARING, BALL	1
21	PAFZZ	82402	49001C10	. SHIM	V
22	PBFZZ	82402	42277D146	. RETAINER, BEARING	1
23	PBFZZ	82402	42277D158	. SHAFT, CAM	1
24	PBFZZ	82402	42277D197	. SHAFT, SWITCH BRACKET	1
25	PAFZZ	82402	49001C6	. SHIM	V
26	PAFZZ	82402	42277C150	. SPACER	1
27	PBFZZ	82402	42277D185	. CAM ASSY, LIMIT SWITCH	4
28	PBFZZ	82402	42305D186	. CAM ASSY	1
29	PAFZZ	82402	42277C149	. SPACER	3
30	PAFZZ	12143	PT06SE12-8P(SR)	. PLUG, STRAIGHT	1
31	PAFZZ	88044	AN525D832-8	. SCREW	1
32	PAFZZ	96906	MS21333-69	. CLAMP	1
33	PAFZZ	96906	MS25036-149	. TERMINAL, LUG	1
34	PAFZZ	96906	MS21333-69	. CLAMP	1
35	PAFZZ	96906	MS21083D08	. NUT	1
36	PAFZZ	04426	76-2190-404	. SWITCH	1
37	PAFZZ	88044	AN960PD416L	. WASHER	1
38	PBFZZ	82402	42305C122	. CAP	1
39	PAFZZ	96906	MS35489-38	. GROMMET	1

TM 55-1680-320-23&P

(1) ITEM NO.	(2) SMR CODE	(3) FSCM	(4) PART NUMBER	(5) DESCRIPTION AND USABLE ON CODE (UOC)	(6) QTY
40	PBFZZ	82402	42277D151	. BRACKET, SWITCH	4
41	PAFZZ	96906	MS16998-29	. SCREW	4
42	PAFZZ	83533	C0300-032-0440S	. SPRING, COMPRESSION	4
43	PAFZZ	15653	MF7200-3	. NUT, STAKE	4
44	PAFZZ	91929	1SE2-3	. SWITCH, LIMIT	2
45	PAFZZ	91929	1SE2	. SWITCH, LIMIT	2
46	PAFZZ	91929	JE5	. SWITCH ACTUATOR	4
47	PAFZZ	82402	4067C193	. NUT PLATE ASSY	4
48	PAFZZ	96906	MS51957-9	. SCREW	8
49	PAFZZ	82402	42277C228	. SPACER	1
50	XAFFF	82402	42277R196	. HOUSING ASSY, LIMIT SWITCH DRIVE	1
51	PAFZZ	96906	MS21209C0615P	.. INSERT	4
52	PBFZZ	96906	MS21209C0815P	.. INSERT	2
END OF FIGURE					

**THIS PAGE
INTENTIONALLY
LEFT BLANK**

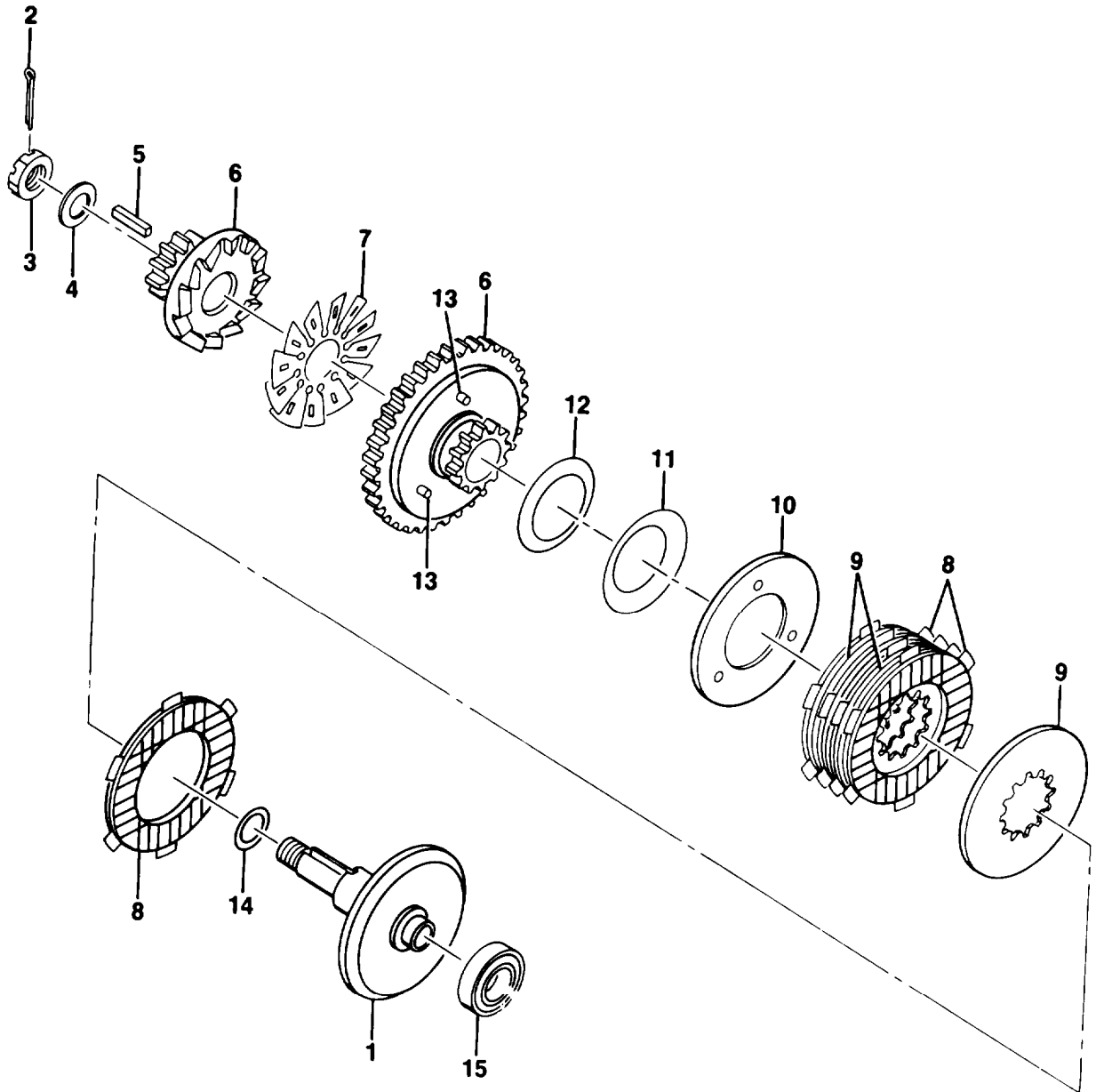


FIGURE C-22. AUTOMATIC BRAKE ASSY

(1) ITEM NO.	(2) SMR CODE	(3) FSCM	(4) PART NUMBER	(5) DESCRIPTION AND USABLE ON CODE (UOC)	(6) QTY
GROUP 0504: AUTOMATIC BRAKE ASSEMBLY					
FIG. C-22 AUTOMATIC BRAKE ASSY					
	PAFFF	82402	42305E200	AUTOMATIC BRAKE ASSY (SEE FIG. C-18 FOR NHA)	REF
1	PAFZZ	82402	42305E203	SHAFT, AUTOMATIC BRAKE	1
2	PAFZZ	96906	MS24665-134	PIN, COTTER	1
3	PAFZZ	88044	AN320-7	NUT, CASTELLATED	1
4	PAFZZ	88044	AN960-716	WASHER, FLAT	1
5	PAFZZ	82402	49008C99	KEY, MACHINE SQUARE	1
6	PAFZZ	80402	42305D219	GEAR CAM SEAT	1
7	PAFZZ	82402	42277D215	CAGE ASSY, ROLLER	1
8	PAFZZ	82402	42325-255	FRICITION DISC	5
9	PAFZZ	82402	42277D160	BRAKE DISC	4
10	PAFZZ	82402	42305D190	PRESSURE PLATE	1
11	PAFZZ	82402	42305-212	SPRING, BELLEVILLE	1
12	PAFZZ	82402	42305-228	SPRING, BELLEVILLE	1
13	PAFZZ	96906	MS9486-50	PIN, DOWEL	3
14	PAFZZ	82402	49001C8	SHIM	1
15	PAFZZ	21335	1902S	BEARING, BALL	1

END OF FIGURE

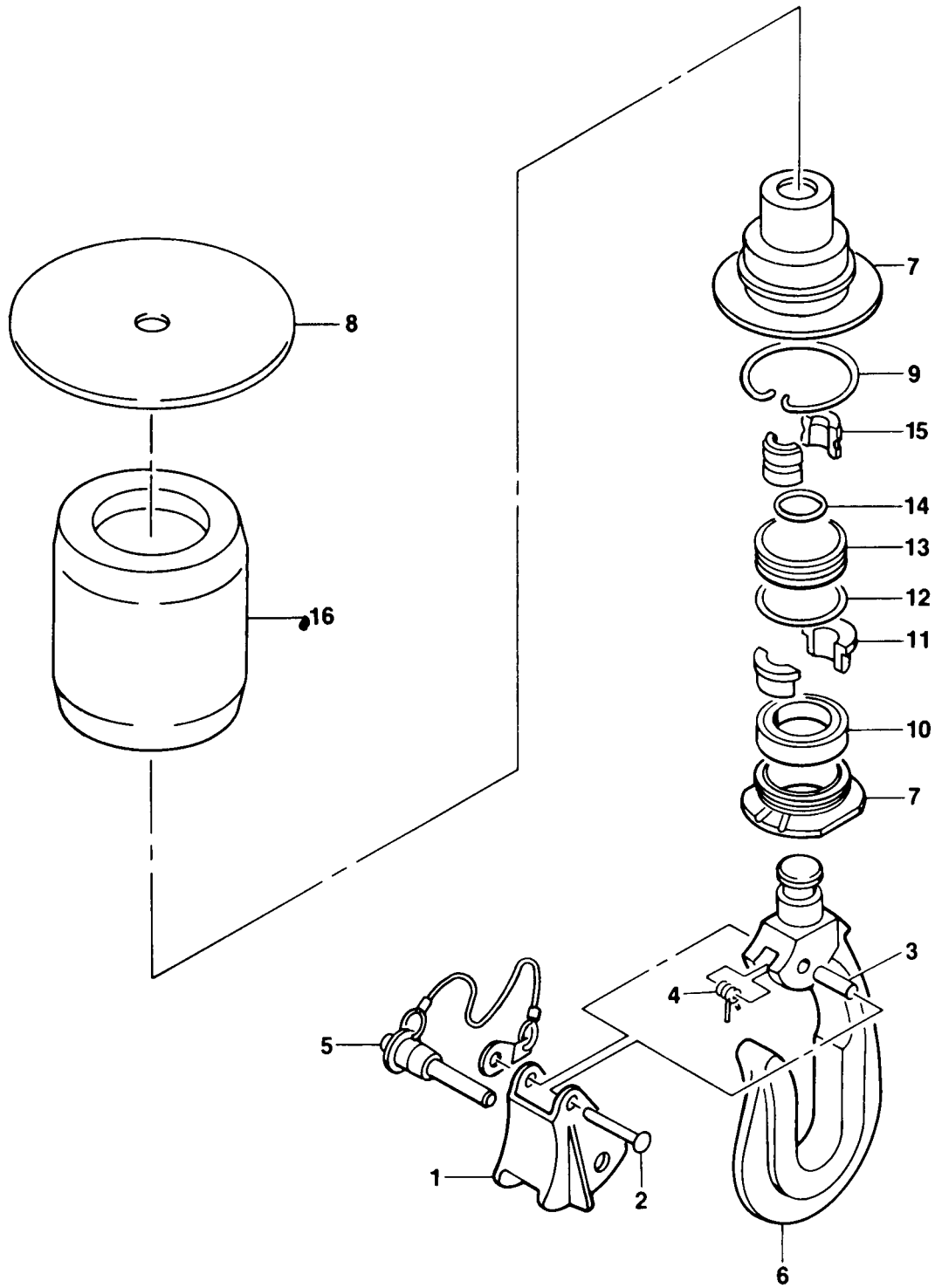


FIGURE C-23. HOOK ASSY, CABLE

TM 55-1680-320-23&P

(1) ITEM NO.	(2) SMR CODE	(3) FSCM	(4) PART NUMBER	(5) DESCRIPTION AND USABLE ON CODE (UOC)	(6) QTY
				GROUP 0505: HOOK ASSEMBLY, CABLE	
				FIG. C-23. HOOK ASSY, CABLE	
	PAOOO	82402	42305E280	HOOK ASSY, CABLE (SEE (FIG. C-18 FOR NHA)	REF
1	PAOZZ	82402	42277D285	. KEEPER, CABLE HOOK	1
2	PBOZZ	82402	MS20613-4C20	. RIVET	1
3	PAOZZ	82402	42277C286	. BUSHING	1
4	PAOZZ	82402	42277D288	. SPRING, TORSION.	1
5	PAOZZ	82402	42277D293	. PIN ASSY, RELEASE	1
6	PBOZZ	82402	42305E281	. HOOK, HOIST CABLE	1
7	PBOZZ	82402	42305D287	. CARRIER ASSY	1
8	PBOZZ	82402	42277D291	. DISK, STRIKER.	1
9	PAOZZ	82402	42277D289	. LOCKSPRING, CARRIER	1
10	PAOZZ	38443	KP10A	. BEARING, BALL	1
11	PAOZZ	82402	42234D402	. RETAINER, SPLIT	1
12	PAOZZ	96906	MS28775-023	. PACKING	1
13	PBOZZ	82402	42277D284	. CAP SEAL, RETAINER.	1
14	PAOZZ	96906	MS28775-016	. PACKING	1
15	PAOZZ	82402	42234D405	. RETAINER, SPLIT	1
16	PBOZZ	82402	42305D290	. BOOT, CABLE HOOK	1
				END OF FIGURE	

Section III SPECIAL TOOLS LIST

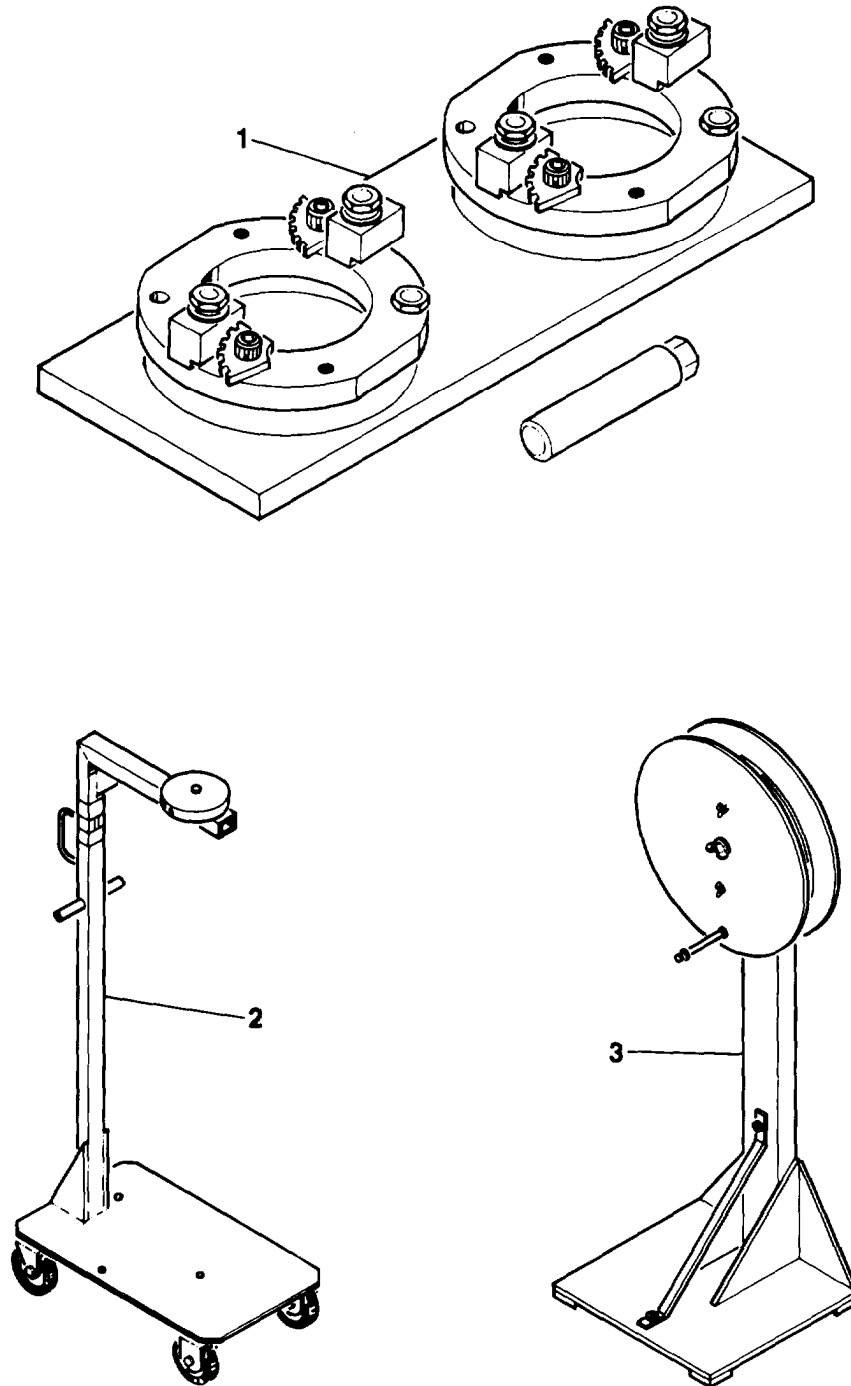


FIGURE C-24 SPECIAL TOOLS (SHEET 1 OF 2)

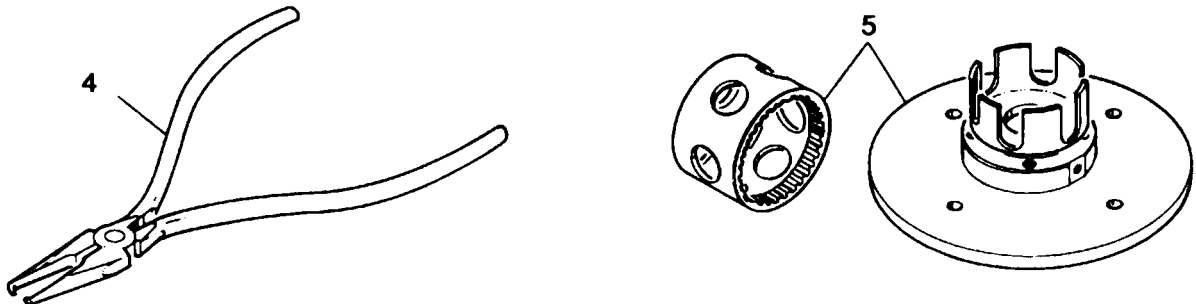


FIGURE C-24. SPECIAL TOOLS (SHEET 2 OF 2)

(1) ITEM NO.	(2) SMR CODE	(3) FSCM	(4) PART NUMBER	(5) DESCRIPTION AND USABLE ON CODE (UOC)	(6) QTY
				GROUP 07: SPECIAL TOOLS	
				FIG. C-24. SPECIAL TOOLS	
1	XDFZZ	82402	42277-716	HOLDING FIXTURE, CLUTCH AND BRAKE BOI: 1 AUTH FOR END ITEM	
2	XDFZZ	82402	42277-808	ASSEMBLY STAND BOI: 1 AUTH FOR END ITEM . . .	1
3	XDOZZ	82402	42277-730	CABLE SPOOL BOI: 1 AUTH FOR END ITEM . . .	1
4	XDOZZ	82402	44191D192	PLIER GRIP BOI: 1 AUTH FOR END ITEM . . .	1
5	PAFZZ	82402	42277-728	TORQUE FIXTURE, AUTOMATIC BRAKE BOI: 1 AUTH FOR END ITEM	1
				END OF FIGURE	

**THIS PAGE
INTENTIONALLY
LEFT BLANK**

SECTION IV. NATIONAL STOCK NUMBER AND PART NUMBER INDEX
 NATIONAL STOCK NUMBER INDEX

STOCK NUMBER	FIG.	ITEM	STOCK NUMBER	FIG.	ITEM
1377-01-073-3831	3	74A	1680-01-070-0993	18	77
1377-01-087-5166	3	74	1680-01-070-1188	18	108
1615-01-092-7962	19	45	1680-01-070-1189	18	133
1615-01-147-6639	18	1	1680-01-070-1190	23	13
1650-01-075-6505	19	51	1680-01-070-1214	22	9
1650-01-075-6551	19	57	1680-01-070-5392	3	91
1680-00-001-5314	18	68	1680-01-070-5393	12	9
1680-00-001-5314	18	82	1680-01-070-5839	4	3
1680-00-001-6850	23	11	1680-01-070-7546	17	4
1680-00-020-8325	18	67	1680-01-070-7554	6	44
1680-00-020-9478	18	66	1680-01-070-7555	6	82
1680-00-091-6645	18	85	1680-01-070-7556	1	24
1680-00-472-1671	18	71	1680-01-070-7556	2	REF
1680-00-497-7491	23	15	1680-01-070-7557	13	8
1680-00-768-9670	18	56	1680-01-070-7557	13	15
1680-00-769-0425	18	27	1680-01-070-7558	6	43
1680-01-022-5788	3	17	1680-01-070-7559	2	8
1680-01-022-5788	5	REF	1680-01-070-7560	2	15
1680-01-030-9357	15	8	1680-01-070-7561	2	19
1680-01-058-3671	1	REF	1680-01-070-7616	6	10
1680-01-067-3100	21	23	1680-01-070-7724	17	3
1680-01-068-3035	18	20	1680-01-070-7725	17	1
1680-01-070-0965	18	143	1680-01-070-7727	4	4
1680-01-070-0966	18	53	1680-01-070-7727	5	6
1680-01-070-0967	18	128	1680-01-070-9950	1	32
1680-01-070-0968	13	28	1680-01-070-9950	11	REF
1680-01-070-0969	11	48	1680-01-070-9951	12	5
1680-01-070-0969	13	REF	1680-01-070-9952	3	92
1680-01-070-0970	23	7	1680-01-070-9952	4	REF
1680-01-070-0971	18	163	1680-01-070-9953	1	6
1680-01-070-0971	23	REF	1680-01-070-9953	3	REF
1680-01-070-0972	18	50	1680-01-070-9955	3	63
1680-01-070-0973	18	57	1680-01-070-9956	14	7
1680-01-070-0974	18	83	1680-01-070-9957	14	6
1680-01-070-0975	18	118	1680-01-070-9958	14	5
1680-01-070-0976	23	1	1680-01-070-9959	14	11
1680-01-070-0977	18	63	1680-01-070-9960	14	10
1680-01-070-0977	22	REF	1680-01-070-9961	14	9
1680-01-070-0985	1	28	1680-01-070-9962	15	2
1680-01-070-0985	6	REF	1680-01-070-9964	11	63
1680-01-070-0986	18	162	1680-01-070-9964	17	12
1680-01-070-0986	20	REF	1680-01-070-9965	17	9
1680-01-070-0987	13	1	1680-01-070-9966	17	6
1680-01-070-0988	13	3	1680-01-070-9974	11	82
1680-01-070-0989	13	19	1680-01-070-9974	17	REF
1680-01-070-0990	18	81	1680-01-070-9976	11	71
1680-01-070-0991	18	48	1680-01-070-9977	22	6
1680-01-070-0992	18	122			

NATIONAL STOCK NUMBER INDEX (cont)

STOCK NUMBER	FIG.	ITEM	STOCK NUMBER	FIG.	ITEM
1680-01-071-0134	12	7	1680-01-082-1130	23	16
1680-01-071-0134	12	11	1680-01-082-7811	21	16
1680-01-071-0174	20	1	1680-01-082-8321	1	23
1680-01-071-0176	11	19	1680-01-082-9695	21	27
1680-01-071-0177	11	83	1680-01-082-9696	21	40
1680-01-071-0178	11	3	1680-01-082-9699	18	32
1680-01-071-0210	5	7	1680-01-082-9699	21	REF
1680-01-071-5373	3	21	1680-01-082-9700	21	1
1680-01-071-5374	3	81	1680-01-082-9701	21	28
1680-01-071-5375	3	44	1680-01-083-3414	11	35
1680-01-071-5376	3	28	1680-01-087-9443	11	52
1680-01-071-5377	3	18	1680-01-089-4331	1	31
1680-01-071-5379	14	14	1680-01-089-4331	18	REF
1680-01-071-5380	11	15	1680-01-099-6309	18	130
1680-01-071-5389	11	59	1680-01-099-6310	3	9
1680-01-071-5392	18	90	1680-01-099-6311	11	72
1680-01-071-5515	18	34	1680-01-099-6312	11	57
1680-01-071-5516	20	9	1680-01-099-6314	11	43
1680-01-071-5517	20	4	1680-01-099-6315	17	8
1680-01-071-9211	3	88	1680-01-102-8760	1	5
1680-01-071-9215	11	32	1680-01-111-0186	16	2
1680-01-071-9545	1	25	1680-01-112-2994	1	3
1680-01-071-9665	19	4	1680-01-122-3580	1	16
1680-01-071-9665	19	53	1680-01-126-4128	19	40
1680-01-071-9669	11	55	1680-01-128-6330	19	46
1680-01-072-1481	23	8	1680-01-146-0887	18	23
1680-01-072-1731	11	56	1680-01-146-0888	18	89
1680-01-072-5919	11	70	1680-01-146-8059	6	83
1680-01-072-9963	11	51	1680-01-147-6715	8	23
1680-01-072-9963	15	REF	1680-01-147-6716	6	86
1680-01-073-3358	6	13	1680-01-147-6716	9	REF
1680-01-073-3842	20	10	1680-01-151-9214	6	74
1680-01-075-2219	22	1	1680-01-151-9214	6	88
1680-01-075-2221	11	87	1680-01-151-9214	6	71
1680-01-075-2222	15	14	1680-01-160-6033	3	39
1680-01-075-2234	11	50	1680-01-201-7835	4	8
1680-01-075-2234	14	REF	1680-01-201-7835	5	2
1680-01-076-4802	18	156	1680-01-201-7836	6	78
1680-01-077-6892	18	15	1680-01-212-1386	17	2
1680-01-077-6896	3	84	1680-01-231-4829	9	51
1680-01-077-6897	18	51	1680-01-271-5299	2	1
1680-01-078-4181	2	22	1680-01-391-9984	11	4
1680-01-078-6045	20	6	1680-01-391-9984	16	REF
1680-01-078-6059	4	2	2805-01-060-7633	10	19
1680-01-078-6059	5	8	2925-01-147-6688	10	27
1680-01-079-6644	22	8	3020-00-575-2897	15	10
			3020-01-068-1504	21	19

NATIONAL STOCK NUMBER INDEX (cont)

STOCK NUMBER	FIG.	ITEM	STOCK NUMBER	FIG.	ITEM
3020-01-068-1505	21	9	3110-00-710-4936	21	20
3020-01-068-1506	18	115	3110-00-782-0417	18	95
3020-01-068-1568	18	104	3110-00-782-0417	18	120
3020-01-068-1568	21	7	3110-00-838-5033	2	9
3020-01-068-2101	21	18	3110-00-868-2669	18	147
3020-01-069-6912	18	148	3110-00-868-2669	22	15
3020-01-069-8447	18	98	3110-00-902-3840	14	3
3020-01-069-9243	22	10	3110-01-009-6768	8	49
3020-01-070-2521	13	16	3110-01-027-3186	18	54
3020-01-070-2521	13	21	3110-01-069-4978	21	22
3020-01-070-4579	13	11	3110-01-069-9121	15	11
3020-01-070-8559	3	31	3110-01-075-0830	19	38
3020-01-071-2843	18	107	3110-01-075-2082	19	10
3020-01-071-2905	14	2	3110-01-075-5287	2	10
3020-01-071-2908	14	4	3110-01-078-5025	18	101
3020-01-072-3615	18	96	3110-01-078-4983	22	7
3020-01-073-9890	3	43	3110-01-083-3260	4	9
3020-01-076-0566	3	32	3110-01-083-3260	5	1
3020-01-076-3464	18	84	3110-00-710-4936	15	5
3020-01-078-1069	18	158	3120-00-230-6596	18	86
3020-01-078-6108	18	136	3120-00-854-6166	3	56
3020-01-079-3138	13	2	3120-00-970-4623	18	29
3020-01-698-8854	13	29	3120-01-056-1584	3	29
3040-01-070-5122	3	37	3120-01-072-9236	20	3
3040-01-071-2902	15	18	3120-01-074-7510	18	60
3040-01-072-4387	18	58	3120-01-077-1610	12	49
3040-01-072-4524	18	138	3120-01-078-2842	23	3
3110-00-017-8900	21	15	3120-01-080-0821	3	16
3110-00-027-8143	15	15	3120-01-088-6907	18	135
3110-00-059-7131	21	17	3120-01-108-2420	2	17
3110-00-068-9393	18	137	3120-01--137-9069	11	89
3110-00-106-8823	16	3	3130-00-406-0601	18	24
3110-00-109-1183	18	99	3505-00-253-5606	1	10
3110-00-147-1155	3	64	3505-00-253-5606	2	31
3110-00-156-5190	3	26	3505-00-253-5606	3	53
3110-00-180-7284	18	157	3505-00-253-5606	11	25
3110-00-186-1104	18	126	3505-00-253-5606	12	57
3110-00-191-3236	13	12	3505-00-253-5606	18	154
3110-00-198-2050	3	33	3515-00-013-7214	11	64
3110-00-203-4097	10	18	3515-00-842-3044	17	17
3110-01-271-5982	16	4	4010-01-168-0123	18	70
3110-00-293-8889	10	21	4030-01-071-0121	23	6
3110-00-293-9605	18	114	4140-01-212-1433	6	85
3110-00-455-2433	23	10	4140-01-212-1433	10	REP
3110-00-516-5377	18	141	4730-00-278-3462	18	46
3110-00-678-5425	3	66	5110-00-918-3027	3	90
			5110-00-918-3027	11	36

NATIONAL STOCK NUMBER INDEX (cont)

STOCK NUMBER	FIG.	ITEM	STOCK NUMBER	FIG.	ITEM
5110-00-918-3027	11	77	5305-00-622-9476	21	10
5110-00-918-3027	21	47	5305-00-622-9479	11	46
5150-01-154-9661	7	7	5305-00-680-0543	19	1
5190-00-010-8718	8	53	5305-00-680-0543	19	54
5190-00-010-8718	9	10	5305-00-709-2013	18	69
5305-00-001-5326	18	73	5305-00-764-2964	2	16
5305-00-051-6521	11	85	5305-00-771-0522	13	30
5305-00-052-7004	6	42	5305-00-824-2024	3	85
5305-00-052-8250	11	33	5305-00-869-1097	6	39
5305-00-054-5643	11	37	5305-00-883-9304	12	50
5305-00-054-5643	11	78	5305-00-889-3001	8	59
5305-00-054-5643	21	48	5305-00-889-3116	11	60
5305-00-054-5643	3	86	5305-00-889-3118	7	43
5305-00-054-5647	2	25	5305-00-931-8601	6	40
5305-00-054-6668	2	18	5305-00-934-0114	11	42
5305-00-058-9363	2	21	5305-00-954-9010	7	23
5305-01-066-1860	6	79	5305-00-957-6272	10	1
5305-00-071-1322	3	10	5305-00-957-7816	11	58
5305-00-132-1497	6	12	5305-00-958-6230	10	14
5305-00-132-1497	6	68	5305-00-958-6230	12	32
5305-00-132-1497	6	99	5305-00-978-9346	21	2
5305-00-145-0700	11	30	5305-00-978-9349	7	30
5305-00-150-9775	12	45	5305-00-978-9350	7	29
5305-00-151-0376	11	49	5305-00-978-9355	11	95
5305-00-151-0376	11	73	5305-00-983-6652	18	33
5305-00-182-9570	6	18	5305-00-983-6652	21	41
5305-00-182-9570	6	84	5305-00-983-6653	3	50
5305-00-207-3929	21	31	5305-00-984-4983	11	53
5305-00-231-9423	3	77	5305-00-984-4989	8	16
5305-00-271-7746	1	20	5305-00-984-6194	6	47
5305-00-297-4013	12	24	5305-00-984-6226	10	34
5305-00-308-9735	11	22	5305-00-984-6933	19	48
5305-00-459-1172	6	91	5305-00-989-7434	3	13
5305-00-459-1172	19	41	5305-00-990-6444	11	8
5305-00-459-4687	2	28	5305-00-993-0191	11	61
5340-00-558-5323	1	12	5305-00-993-5767	8	15
5340-00-558-5323	3	70	5305-00-993-5767	8	61
5305-00-514-7506	19	31	5305-00-995-3442	18	110
5305-00-559-8144	10	5	5305-00-995-3444	3	15
5305-00-579-2138	12	2	5305-01-031-1020	14	12
5305-00-614-0246	1	13	5305-01-052-1488	6	25
5305-00-614-0246	1	19	5305-01-052-1488	6	73
5305-00-614-0248	18	12	5305-01-052-1488	8	3
5305-00-614-0261	12	15	5305-01-071-7111	10	7
5305-00-614-0286	2	11	5305-01-073-3636	6	63
5305-00-614-0288	2	7	5305-01-073-3636	6	87
5305-00-616-4831	18	19	5305-01-073-3636	8	2

NATIONAL STOCK NUMBER		INDEX (cont)			
STOCK NUMBER	FIG.	ITEM	STOCK NUMBER	FIG.	ITEM
5305-01-073-5052	6	77	5310-00-167-0834	6	33
5305-01-074-1462	3	75	5310-00-167-0835	6	49
5305-01-078-5069	7	13	5310-00-167-0836	6	27
5305-01-084-4655	2	2	5310-00-167-0836	7	12
5305-01-088-0263	11	7	5310-00-167-0837	6	30
5305-01-096-2434	19	14	5310-00-167-0841	17	21
5305-01-102-1857	18	134	5310-00-176-8108	18	87
5306-00-144-4041	11	18	5310-00-176-8109	18	97
5306-00-150-9527	3	5	5310-00-176-8111	22	3
5306-00-150-9528	3	73	5310-00-184-8966	21	11
5306-00-150-9874	18	35	5310-00-184-8970	7	20
5306-00-151-0778	3	46	5310-00-184-8977	6	61
5306-00-180-2778	3	65	5310-00-184-8977	7	31
5306-00-182-1852	18	39	5310-00-184-8977	8	17
5306-00-182-1854	3	6	5310-00-184-9001	21	37
5306-00-182-1888	1	29	5310-00-184-9002	11	74
5306-00-275-9564	1	1	5310-00-187-2354	18	45
5306-00-816-0117	3	82	5310-00-187-2398	11	54
5306-00-818-7516	18	44	5310-00-187-2399	18	40
5306-00-975-2073	1	7	5310-00-187-2400	17	19
5306-01-125-5446	21	24	5310-00-188-7721	21	3
5307-01-078-4001	7	16	5310-00-243-3933	17	7
5307-01-080-2270	17	23	5310-00-261-8278	6	41
5307-01-223-3184	11	92	5310-00-261-8278	8	9
5310-00-004-5033	6	28	5310-00-407-9566	6	31
5310-00-045-3296	6	34	5310-00-478-9768	7	24
5310-00-061-7326	3	36	5310-00-479-4161	7	11
5310-00-061-7326	3	48	5310-00-515-7592	18	103
5310-00-087-3155	12	37	5310-00-559-0070	10	33
5310-00-141-1795	1	30	5310-00-576-0546	6	22
5310-00-149-9146	1	2	5310-00-576-0546	6	60
5310-00-158-5280	7	14	5310-00-584-3782	11	62
5310-00-165-1886	8	10	5310-00-595-7484	13	33
5310-00-167-0702	7	18	5310-00-616-6791	7	42
5310-00-167-0753	18	13	5310-00-616-6822	11	41
5310-00-167-0753	3	47	5310-00-616-6822	11	79
5310-00-167-0753	21	13	5310-00-619-6446	18	102
5310-00-167-0816	7	34	5310-00-655-7549	3	40
5310-00-167-0816	8	4	5310-00-660-2084	3	87
5310-00-167-0816	8	62	5310-00-680-7296	3	35
5310-00-167-0816	19	49	5310-00-805-7632	18	28
5310-00-167-0822	22	4	5310-00-805-7632	18	30
5310-00-167-0833	6	20	5310-00-807-1467	3	51
5310-00-167-0833	6	53	5310-00-807-1472	7	35
5310-00-167-0834	11	96	5310-00-807-1472	8	18
5310-00-167-0834	8	8	5310-00-807-1472	8	63
			5310-00-807-1472	13	31

NATIONAL STOCK NUMBER INDEX (cont)

STOCK NUMBER	FIG.	ITEM	STOCK NUMBER	FIG.	ITEM
5310-00-807-1473	6	23	5315-00-678-5218	18	159
5310-00-807-1473	11	47	5315-00-687-5218	4	7
5310-00-807-1475	7	19	5315-00-688-0373	18	105
5310-00-819-5413	3	7	5315-00-688-0373	21	6
5310-00-822-2077	7	17	5315-00-729-6991	18	75
5310-00-857-5558	12	34	5315-00-732-2841	3	22
5310-00-877-5797	11	97	5315-00-810-3701	7	22
5310-00-902-6676	1	14	5315-00-811-6495	18	8
5310-00-902-6676	1	21	5315-00-820-8051	18	10
5310-00-902-6676	18	14	5315-00-836-1422	18	9
5310-00-905-3081	21	12	5315-00-839-2326	3	61
5310-00-905-8434	6	35	5315-00-839-5820	18	88
5310-00-905-8434	6	29	5315-00-839-5820	22	2
5310-00-905-8451	19	50	5315-00-927-7893	3	30
5310-00-906-9552	19	37	5315-00-959-5500	17	18
5310-00-926-5832	6	32	5315-00-959-6762	18	7
5310-00-934-9757	6	48	5315-00-990-6023	18	76
5310-00-934-9762	6	21	5315-01-071-8271	13	9
5310-00-934-9763	8	21	5315-01-072-9585	18	42
5310-00-941-6019	11	75	5315-01-073-2976	3	38
5310-00-941-6640	21	35	5315-01-075-0941	13	17
5310-00-950-1310	12	33	5315-01-075-0941	13	23
5310-00-955-1295	21	43	5315-01-075-2126	3	41
5310-00-956-0054	10	16	5315-01-077-7289	18	80
5310-00-988-0443	10	25	5315-01-091-1413	15	7
5310-00-998-5039	6	54	5315-01-105-9202	11	91
5310-01-006-9021	15	9	5315-01-116-6789	2	14
5310-01-007-1565	3	14	5315-01-162-5032	17	13
5310-01-007-1565	18	109	5320-00-117-7208	11	17
5310-01-007-6897	8	7	5320-00-233-4800	14	8
5310-01-069-0525	21	39	5320-00-860-6605	11	44
5310-01-073-2948	17	10	5320-00-860-6605	19	33
5310-01-073-2949	17	16	5320-00-881-6193	23	2
5310-01-073-9225	4	5	5320-00-990-2844	18	92
5310-01-073-9225	5	5	5325-00-276-6100	11	2
5310-01-074-7453	11	16	5325-00-582-3601	21	53
5310-01-077-1029	11	65	5325-01-077-4876	19	44
5310-01-105-7122	12	28	5330-00-166-0975	18	61
5310-01-151-1708	3	59	5330-00-166-0990	18	78
5310-01-167-0831	10	15	5330-00-166-0990	18	139
5310-01-198-2313	6	97	5330-00-166-0992	18	124
5310-01-379-1125	22	11	5330-00-166-8395	21	14
5310-01-379-1169	22	12	5330-00-166-8404	18	112
5315-00-139-7064	22	13	5330-00-167-5166	18	132
5315-00-143-9681	18	93	5330-00-171-9225	18	111
5315-00-584-9221	17	20	5330-00-285-4142	18	123
5315-00-687-5218	5	3	5330-00-579-7545	11	31

NATIONAL STOCK NUMBER INDEX (cont)

STOCK NUMBER	FIG.	ITEM	STOCK NUMBER	FIG.	ITEM
5330-00-579-8108	12	3	5340-00-915-2342	8	11
5330-00-582-1548	18	62	5340-00-924-5909	18	4
5330-00-584-0265	3	79	5340-00-973-6933	18	21
5330-00-584-0266	3	10	5340-00-995-6690	18	6
5330-00-684-3419	23	14	5340-00-998-0611	8	60
5330-00-684-3420	3	23	5340-01-030-9500	2	12
5330-00-702-1048	19	3	5340-01-035-4121	21	52
5330-00-727-2637	23	12	5340-01-047-8340	21	51
5330-00-802-2130	11	5	5340-01-072-9343	10	9
5330-00-810-9659	18	131	5340-01-072-9343	12	29
5330-00-810-9659	18	151	5340-01-073-1579	18	36
5330-00-940-9475	19	39	5340-01-075-2154	1	17
5330-00-970-2710	18	160	5340-01-084-5152	11	6
5330-01-005-0525	18	116	5340-01-089-4259	11	66
5330-01-025-7777	15	13	5340-01-095-5668	10	11
5330-01-048-5000	18	47	5340-01-105-7110	23	5
5330-01-058-7109	15	3	5340-01-106-3690	11	21
5330-01-071-0432	3	8	5340-01-132-8945	17	14
5330-01-076-5704	18	121	5340-01-135-2525	11	82
5330-01-095-3724	18	117	5340-01-225-3954	11	23
5330-01-095-5739	18	52	5360-01-026-0217	3	83
5330-01-118-7701	3	20	5360-01-072-1353	23	4
5330-01-193-0318	3	24	5360-01-073-1187	3	42
5330-01-215-7137	6	36	5360-01-073-5416	2	20
5340-00-021-3495	11	11	5360-01-074-7823	20	8
5340-00-021-3495	18	2	5360-01-078-5578	14	1
5340-00-021-3495	18	26	5360-01-078-5578	14	13
5340-00-021-3495	3	57	5360-01-080-2013	12	19
5340-00-054-1408	17	11	5360-01-095-3662	21	42
5340-00-057-2904	1	18	5360-01-105-7037	17	15
5340-00-057-2904	3	72	5365-00-021-1729	18	74
5340-00-085-0219	3	58	5365-00-058-9557	4	6
5340-00-085-0219	18	25	5365-00-058-9557	5	4
5340-00-085-0219	3	69	5365-00-072-9729	12	17
5340-00-085-0219	18	3	5365-00-102-9621	13	13
5340-00-094-3554	1	27	5365-00-119-9352	10	32
5340-00-165-7832	1	26	5365-00-121-3558	18	100
5340-00-324-9146	11	90	5365-00-141-6943	19	43
5340-00-471-3745	18	16	5365-00-161-4109	10	31
5340-00-598-8251	1	15	5365-00-162-7874	10	30
5340-00-598-8251	1	22	5365-00-272-5583	16	5
5340-00-764-7051	3	71	5365-00-281-9885	4	1
5340-00-764-7051	21	32	5365-00-281-9885	5	9
5340-00-764-7051	21	34	5365-00-285-6784	18	72
5340-00-783-9139	18	5	5365-00-289-3070	18	152
5340-00-793-0760	11	14	5365-00-289-3073	3	11
5340-00-793-0760	11	29	5365-00-302-8098	11	40

NATIONAL STOCK NUMBER INDEX (cent)

<u>STOCK NUMBER</u>	<u>FIG.</u>	<u>ITEM</u>	<u>STOCK NUMBER</u>	<u>FIG.</u>	<u>ITEM</u>
5365-00-347-8254	12	30	5365-01-072-2925	12	16
5365-00-347-8254	10	8	5385-01-072-2926	3	67
5365-00-454-8687	12	52	5365-01-072-2932	12	54
5365-00-455-6940	6	72	5385-01-072-9358	3	46
5365-00-514-8291	18	65	5365-01-072-9731	12	36
5365-00-531-9454	13	10	5365-01-072-9733	12	18
5365-00-720-8064	18	106	5365-01-073-3030	7	2
5365-00-720-8064	21	5	5365-00-111-7417	7	4
5365-00-800-8270	16	7	5365-01-073-3033	15	16
5365-00-805-1401	12	55	5365-01-073-5452	12	53
5365-00-808-0845	18	84	5385-01-075-6445	7	10
5365-00-900-0965	20	11	5385-01-075-7741	3	25
5365-01-053-3337	18	125	5365-01-078-4121	7	25
5365-01-053-3337	18	142	5385-01-078-5625	15	4
5365-01-053-3337	18	145	5385-01-078-9529	13	26
5365-01-053-3337	22	14	5365-01-081-5692	10	24
5365-01-056-5073	21	21	5365-01-095-6882	7	32
5365-01-058-5831	21	29	5365-01-095-6882	8	20
5365-01-060-3788	10	17	5365-01-105-7114	21	49
5365-01-060-3788	12	35	5365-01-105-7132	20	14
5365-01-065-7320	19	7	5365-01-105-7133	20	13
6365-01-085-7321	19	8	5365-01-105-7134	20	12
5365-01-065-7322	19	9	5365-01-108-4280	1	4
5365-01-068-5632	21	8	5365-01-133-0264	6	89
5365-01-068-8553	18	144	5385-01-133-6174	6	55
5365-01-088-8553	21	128	5365-01-212-1437	16	6
6365-01-069-1803	3	34	5365-01-454-8684	10	23
5365-01-069-1803	21	25	5365-01-836-2808	10	22
5365-01-070-2807	18	55	5365-01-938-0138	18	119
5365-01-071-2386	18	127	5691-00-262-0814	7	28
5365-01-071-3639	13	32	5905-00-008-2978	9	49
5365-01-071-3640	18	113	5905-00-008-5575	9	40
6385-01-071-3840	18	140	5905-00-043-3127	9	28
5365-01-071-3641	13	24	5905-00-099-0479	9	53
5365-01-071-3642	13	4	5905-00-105-7764	9	52
5365-01-071-3643	13	5	5905-00-106-1M6	8	46
5365-01-071-3644	13	6	5905-00-106-3666	9	23
5365-01-071-3645	13	22	5905-00-106-9344	8	50
5365-01-071-3646	13	18	5905-00-108-9348	8	45
5365-01-071-3929	23	9	5905-00-106-9351	8	56
5365-01-071-3973	19	36	5905-00-106-9356	9	39
5365-01-071-4972	19	35	5905-00-110-0198	8	40
5365-01-071-4975	19	34	5905-00-110-7620	9	30
5365-01-071-7559	18	146	5905-00-110-7622	9	34
5365-01-071-8480	18	91	5905-00-111-1679	9	33
5365-01-071-8480	18	94	5905-00-111-4727	9	22
5365-01-072-0192	3	27	5905-00-111-4858	9	27

NATIONAL STOCK NUMBER INDEX (cont)

STOCK NUMBER	FIG.	ITEM	STOCK NUMBER	FIG.	ITEM
5905-00-111-4858	9	32	5950-01-102-3992	6	17
5905-00-114-0708	9	29	5905-01-N77-0757	8	35
5905-00-114-0710	9	38	5910-00-010-8666	9	16
5905-00-114-0711	9	25	5910-00-096-4644	9	17
5905-00-116-8556	9	56	5910-00-099-0538	9	12
5905-00-121-9861	8	42	5910-00-112-4337	9	18
5905-00-126-6683	9	31	5910-00-113-5475	8	30
5905-00-126-6710	9	42	5910-00-113-5475	9	14
5905-00-135-6046	9	21	5910-00-113-5499	9	15
5905-00-138-1283	9	24	5910-00-236-8766	8	49
5905-00-139-1989	6	67	5910-00-236-8767	8	33
5905-00-141-0599	8	51	5910-00-495-0042	9	13
5905-00-141-0727	8	41	5910-00-495-0042	8	31
5905-00-141-1071	8	54	5910-00-761-7112	8	48
5905-00-141-1168	8	56	5910-01-212-1423	6	45
5905-00-146-4164	9	36	5915-01-101-3888	6	26
5905-00-165-3108	9	44	5930-00-137-1511	11	38
5905-00-194-8405	9	57	5930-00-258-4624	2	23
5905-00-197-4289	8	36	5930-00-538-6790	11	39
5905-00-197-4289	9	37	5930-00-538-6790	11	80
5905-00-211-1318	7	41	5930-00-538-6790	21	46
5905-00-228-6088	8	37	5930-00-553-5920	11	76
5905-00-246-9399	8	47	5930-00-655-1514	6	105
5905-00-247-8710	7	44	5930-00-728-4328	6	108
5905-00-247-8722	7	45	5930-00-729-1662	21	44
5905-00-247-8732	8	34	5930-00-824-9433	2	6
5905-00-401-8689	9	47	5930-00-847-2599	6	96
5905-00-403-3124	9	60	5930-00-917-7083	21	45
5905-00-403-3147	9	59	5930-01-073-8884	18	150
5905-00-405-8355	9	58	5930-01-074-8711	2	5
5905-00-407-2160	9	41	5930-01-078-7566	3	89
5905-00-432-0464	9	35	5930-01-07806491	21	36
5905-00-472-0790	7	40	5930-01-089-1281	3	49
5905-00-479-9952	9	50	5930-01-195-2113	6	109
5905-00-481-3076	9	48	5930-01-216-6525	2	24
5905-00-491-8744	9	46	5935-00-726-6519	3	62
5905-00-506-6606	6	66	5935-00-730-9950	21	30
5905-00-650-9814	9	45	5935-00-755-3630	9	67
5905-00-721-2341	9	55	5935-00-813-2020	18	149
5905-00-721-2348	9	43	5935-00-903-0038	11	1
5905-00-758-3380	9	26	5935-01-071-0348	19	42
5905-00-758-3388	9	54	5935-01- 107-8827	6	98
5905-00-935-8543	8	44	5935-01- 107-8830	6	104
5905-01-008-6215	9	62	5935-01- 107-8855	6	76
5905-01-027-8321	9	63	5935-01- 124-8514	2	27
5905-01-043-6849	9	61	5935-01- 170-0019	6	101
5905-01-076-5608	2	13	5940-00- 113-3136	7	5

NATIONAL STOCK NUMBER INDEX (cent)

STOCK NUMBER	FIG.	ITEM	STOCK NUMBER	FIG.	ITEM
5940-00-114-1316	6	75	5961-01-076-6492	8	58
5940-00-115-2677	6	58	5961-01-081-4805	7	9
5940-00-115-2678	6	57	5961-01-195-0837	6	110
5940-00-143-4771	6	3	5961-01-212-8726	9	9
5940-00-143-4780	6	4	5962-00-370-2637	8	13
5940-00-230-0515	7	46	5962-00-593-6554	8	14
5940-00-283-5280	7	47	5970-00-023-6246	7	36
5940-00-549-4444	8	38	5970-00-144-7668	7	33
5940-00-557-1629	6	2	5970-00-258-2313	7	39
5940-00-557-1629	21	33	5970-00-765-4801	8	22
5940-00-681-8185	2	26	5970-01-074-6856	10	10
5940-00-813-0698	6	1	5970-01-074-6856	12	27
5940-00-813-0698	7	38	5970-01-130-2134	8	19
5940-00-813-0698	10	13	5970-01-209-6142	19	47
5940-00-813-0698	12	31	5975-00-351-6114	12	4
5940-01-020-0872	7	3	5975-00-727-5153	6	5
5940-01-031-1027	6	80	5975-00-727-5153	6	6
5940-01-031-1027	7	48	5977-01-072-8312	12	23
5940-01-050-7460	7	6	5977-01-073-7394	12	26
5940-01-073-1877	7	1	5977-01-075-0901	10	12
5940-01-962-0033	9	64	5977-01-190-5526	19	56
5945-01-020-5009	6	70	5990-01-144-5239	6	103
5945-01-073-2419	6	69	5990-01-195-1989	6	100
5945-01-074-2661	6	50	5999-00-196-9656	8	25
5950-01-074-8739	12	44	5999-00-196-9656	9	65
5950-01-074-8740	12	14	5999-01-071-9221	6	62
5950-01-076-1253	12	12	5999-01-071-9221	8	REF
5950-01-130-7660	6	24	5999-01-074-8839	9	66
5961-00-018-9196	8	52	5999-01-075-7669	7	15
5961-00-018-9196	8	28	5999-01-143-8453	6	102
5961-00-127-9362	8	26	6105-00-407-3909	19	55
5961-01-054-5810	7	8	6105-01-070-7614	18	37
5961-00-752-6121	9	19	6105-01-070-7614	19	REF
5961-00-821-2309	9	20	6105-01-070-7615	10	REF
5961-00-883-3598	8	5	6105-01-071-5413	11	45
5961-00-949-1432	8	24	6105-01-071-5413	12	REF
5961-00-949-1432	9	1	6105-01-073-7452	12	39
5961-00-949-1440	8	43	6105-01-075-6679	19	18
5961-00-949-1440	9	2	6105-01-076-1301	12	40
5961-00-957-6865	8	39	6105-01-076-6582	19	15
5961-01-007-5842	8	27	6105-01-173-2093	10	20
5961-01-016-9906	9	3	6105-01-173-8768	10	6
5961-01-030-5322	7	37	6105-01-195-3330	10	26
5961-01-033-9376	6	7	6105-01-213-5811	10	4
5961-01-070-7629	6	11	6110-01-103-3121	6	64
5961-01-070-7629	7		6120-00-818-0230	6	16
5961-01-072-9781	8	29	6145-00-728-4026	10	3

NATIONAL STOCK NUMBER INDEX (cont)

STOCK NUMBER	FIG.	ITEM	STOCK NUMBER	FIG.	ITEM
6150-00-107-5410	12	20	. . .	17	5
6150-01-073-8442	7	26	- - -	16	1
6150-01-076-3918	6	51	- - -	11	68
6150-01-077-7519	6	52	- - -	11	69
6150-01-079-8863	19	30	. - .	11	67
6150-01-201-7837	10	29	- . .	15	17
6210-00-939-7609	2	3	. - .	14	
6240-00-155-7836	6	15	- - -	11	88
6625-00-179-1684	9	8	- - -	18	41
6625-01-150-3091	6	46	. . -	18	43
6645-01-209-6093	6	92	. - .	18	38
6680-00-070-1212	3	4	. . -	11	26
7690-01-135-2086	6	94	. . .	11	27
7690-01-135-2985	6	93	- - -	11	28
8145-01-076-7476	1	REF	- - -	24	4
9340-00-028-7122	18	17	- - -	22	5
9905-01-086-0452	21	4	. . -	9	4
9905-01-086-4517	3	54	- - -	9	5
9905-01-086-4517	18	153	. . -	9	6
9905-01-122-2121	1	9	- . .	9	7
9905-01-155-8332	18	155	- . .	13	25
9905-01-157-0836	6	65	- - -	19	28
. . -	3	12	- - -	12	25
- . .	14	15	- . .	19	17
. . -	15	1	- - -	8	32
- - -	11	21	- . .	19	11
. . -	13	27	- - -	8	6
- - -	18	11	. . .	18	59
. - .	18	18	- - -	7	49
- - -	21	50	- - -	9	11
- - -	3	60	- - -	6	19
. - .	3	55	- - -	6	14
- - -	3	2	. . -	2	4
- - -	3	1	. - .	6	107
- - -	3	68	- . .	18	129
- - -	11	13	. - .	12	38
. . -	11	12	. . -	15	6
- - -	1	11	. . -	10	28
. . -	20	5	- - -	19	21
- - -	3	52	. . -	12	21
- - -	11	24	- - -	12	13
- - -	2	30	- - -	12	10
- - -	20	7	. . -	12	6
- - -	1	8	. - .	12	1
- - -	11	84	. . .	19	19
- - -	11	86	- - -	19	29
- - -	20	2	. . -	19	20

NATIONAL STOCK NUMBER INDEX (cont)

STOCK NUMBER	FIG.	ITEM	STOCK NUMBER	FIG.	ITEM
. . .	6	90	- - -	12	56
. . .	6		- - -	12	41
- - -	10	2	- - -	19	16
. . .	19	2	- - -	19	12
. . .	19	5	- - -	12	43
. . .	19	6	- - -	6	59
- - -	19	32	- - -	12	8
. . .	19	13	- - -	19	26
. . .	6		- - -	13	14
- . .	6	9	- - -	13	7
. . .	2		- - -	19	22
. . -	2	29	- - -	19	24
. . -	12	22	- - -	19	25
- - -	8	57	- - -	19	27
. . .	8	12	- - -	19	23
. - .	12	42	- - -	12	51
. . .	12	47	- - -	15	12
. . .	6	38	- - -	18	31
- . .	6	37	- - -	24	1
. . .	8	1	- - -	24	5
- - -	6	81	- - -	24	3
- - -	6	56	- - -	24	2
. . .	7	21	- - -	3	3
. . .	7	22	- - -	6	95
. . .	7	27	- - -	11	10
. . .	12	58	- - -	11	
. . .	19	52	- - -	13	20
- - -	12	46	- - -	18	22
. . .	12	48	- - -	18	79

SECTION IV. NATIONAL STOCK NUMBER AND PART NUMBER INDEX

FSCM	PART NUMBER	STOCK NUMBER	FIG.	ITEM
88818	A312A095-101	5365-01-072-5001	8	6
70417	AA921-3	2120-00-406-0601	18	24
88044	AN115807	5305-00-271-7746	1	20
88044	AN174CH6A	5305-00-145-0700	11	31
88044	AN175-4A	5306-00-182-1888	1	29
88044	AN175H10A	5306-00-144-4041	11	18
88044	AN176-24A	5306-00-275-9564	1	1
88044	AN3-16A	5306-00-151-0778	3	46
88044	AN3-25A	5306-00-150-9874	18	35
88044	AN320-4	5310-00-176-8108	18	87
88044	AN320-5	5310-00-176-8109	18	97
88044	AN320-7	5310-00-176-8111	22	3
88044	AN3C4A	5306-00-150-9528	3	73
88044	AN4C5A	5306-00-150-9527	3	5
88044	AN3CH5A	5306-00-182-1854	3	6
88044	AN4CH4A	5306-00-180-2778	3	65
88044	AN502-6-12	5305-01-102-1857	18	134
88044	AN505-10-9	5305-01-096-2434	19	14
88044	AN505-6-7	5305-00-150-9775	12	45
88044	AN505-6R44	5305-00-883-9304	12	50
88044	AN525D832-8	5305-00-207-3929	21	31
88044	AN525D6H2	5305-00-297-4013	12	24
88044	AN5H6	5306-00-182-1852	18	39
88044	AN743-12	5340-00-598-8251	1	15
88044	AN743-12	5340-00-598-8251	1	22
88044	AN931-8-13	5325-00-276-6100	11	2
88044	AN960-1016L	5310-00-167-0841	17	21
88044	AN960-10L	5310-00-167-0834	6	33
88044	AN960-10L	5310-00-167-0834	8	8
88044	AN960-416	5310-00-141-1795	1	30
88044	AN960-416L	5310-00-167-0835	6	49
88044	AN960-4L	5310-01-167-0831	10	15
88044	AN960-516L	5310-00-167-0836	6	27
88044	AN960-516L	5310-00-167-0836	7	12
88044	AN960-6	5310-00-167-0816	7	34
88044	AN960-6	5310-00-167-0816	8	4
88044	AN960-6	5310-00-167-0816	8	62
88044	AN960-6	5310-00-167-0816	19	49
88044	AN960-616L	5310-00-167-0837	6	30
88044	AN960-716	5310-00-167-0822	22	4
88044	AN960-8L	5310-00-167-0833	6	20
88044	AN960-8L	5310-00-167-0833	6	53
88044	AN960B416	5310-00-167-0702	7	18
88044	AN960C-10	5310-00-167-0812	11	96
88044	AN960C4L	5310-00-584-3782	11	62

PART NUMBER INDEX (cont)

FSCM	PART NUMBER	STOCK NUMBER	FIG.	ITEM
88044	AN960PD10	5310-00-167-0753	18	13
88044	AN960PD10L	5310-00-167-0753	3	47
88044	AN960PD10L	5310-00-167-0753	21	13
88044	AN960PD416	5310-00-187-2354	18	45
88044	AN960PD416L	5310-00-184-9001	21	37
88044	AN960PD516	5310-00-187-2399	18	40
88044	AN960PD6	5310-00-188-7721	21	3
88044	AN960PD616	5310-00-187-2400	17	19
88044	AN960PD6L	5310-00-187-2398	11	54
88044	AN960PD8	5310-00-184-8966	21	11
88044	AN960PD8L	5310-00-184-9002	11	74
81343	AS568-035MILG21569C6	5330-01-058-7109	15	3
70925	B-5602	6680-00-070-1212	3	4
96879	B40-24-2	5330-01-025-7777	15	13
60380	B44XOH	3110-00-902-3840	14	3
96906	MS27646-39G	3110-01-271-5982	16	4
38443	B543	3110-01-027-3186	18	54
38443	B545ZZ	3110-00-678-5425	3	66
70925	B5631	9340-00-028-7122	18	17
83553	C0240-024-0500S	5360-01-078-5578	14	1
83553	C0240-024-0500S	5360-01-078-5578	14	13
83533	C0300-032-0440S	5360-01-095-3662	21	42
83553	C0600-045-0750S	---	18	59
08289	DBW1062-330-062	5999-01-075-7669	7	15
08289	DM-123	5970-00-765-4801	8	22
83553	E0360-055-1120M	5360-01-073-1187	3	42
75237	F2400-5	5310-01-074-7453	11	16
70417	FF303-4	3120-00-854-6166	3	56
82402	FV3-4	4140-01-212-1433	6	85
82402	FV3-4	4140-01-212-1433	10	REF
03296	G60T-C10	5325-01-077-4876	19	44
83330	HHS9162	---	7	49
09448	HY515-1	5999-00-196-9656	8	25
09448	HY515-1	5999-00-196-9656	9	65
60380	J108	3110-00-068-9393	18	137
80657	J2816	3110-01-009-6768	18	49
60380	J680H	3110-00-159-7131	21	17
81349	JAN1N3611	5961-00-957-6865	8	39
81349	JAN1N751A	5961-00-821-2309	9	20
81349	JAN1N753A	5961-00-752-6121	9	19
81349	JAN1N914B	5961-01-212-8726	9	9
81349	JAN2N2219A	5961-00-949-1432	8	24
81349	JAN2N2219A	5961-00-949-1432	9	1
81349	JAN2N2905A	5961-00-949-1440	8	43
81349	JAN2N2905A	5961-00-949-1440	9	2
81349	JAN2N6284	5961-00-076-6492	8	58
81349	JAN1N2973B	5961-00-883-3598	8	5
81349	JANTX1N3911R	5961-00-491-2228	7	8

PART NUMBER INDEX (cont)

FSCM	PART NUMBER	STOCK NUMBER	FIG.	ITEM
81349	JANTX2N5686	5961-01-030-5322	7	37
91929	JE12	5930-01-078-7566	3	89
91929	JE5	5930-00-538-6790	11	39
	JE5	5930-00-538-6790	11	80
91929	JE5	5930-00-538-6790	21	46
21366	K1OX13XI3TN	3110-01-069-9121	15	11
35344	KD-D2A	5945-01-073-2419	6	69
29372	KNL524	5340-00-793-0760	11	14
98004	KNL524	5340-00-793-0760	11	29
38443	KP1OA	3110-00-455-2433	23	10
82227	KT1972240H0	6645-01-209-6093	6	92
00141	L3-20	5340-01-030-9500	2	12
27014	LM101AH	6625-00-179-1684	9	8
27014	LM109KSTL/883B	5962-00-370-2637	8	13
16941	LP15D058S13	5305-01-078-5069	7	13
09445	LTD-0510	3120-01-056-1584	3	29
09455	LTD-0816	3120-01-080-0821	3	16
09455	LTD0714	3120-00-230-6596	18	86
09455	LTD102O	3120-01-088-6907	18	135
81349	M24243/1-A302	5320-00-860-6605	11	44
81349	M24243/1-A302	5320-00-860-6605	19	33
81349	M39003-01-0370	5910-00-185-9581	9	11
81349	M39003-01-3006	5910-00-113-5475	8	30
81349	M39003-01-3023	5910-00-761-7112	8	48
81349	M39003-01-3076	5910-00-495-0042	9	13
81349	M39003-01-3094	5910-00-236-8766	8	49
81349	M39003/01-3076	5910-00-495-0042	8	31
81349	M39003/01-3100	5910-00-236-8767	8	33
81349	M39014-01-1321	5910-00-112-4337	9	18
81349	M39014-01-1330	5910-00-096-4644	9	17
81349	M39014-01-1357	5910-00-010-8666	9	16
81349	M39014-02-1342	5910-00-099-0538	9	12
81349	M39014-02-1350	5910-00-113-5499	9	15
81349	M39014102-1338	5190-00-010-8718	8	53
81349	M39014102-1338	5190-00-010-8718	9	10
81349	M39034-01-3006	5910-00-113-5475	9	14
81349	M83248-1-011	5330-00-166-0975	18	61
81349	M83248-1-014	5330-00-166-0990	18	78
81349	M83248-1-014	5330-00-166-0990	18	139
81349	M83248-1-016	5330-00-166-0992	18	124
81349	M83248-1-035	5330-00-166-8395	21	14
81349	M83248-1-905	5330-00-167-5166	18	132
81349	M83248/1-215	5330-00-166-8404	18	112
81349	M83248/1-278	5330-01-005-0525	18	116
81349	M83461/1-127	5330-01-118-7701	3	20
15653	MF7200-3	5310-00-955-1295	21	43
80756	MILR27426	5365-00-900-0965	20	11
81349	MILS22499	5365-00-121-3558	18	100

PART NUMBER INDEX (cont)

FSCM	PART NUMBER	STOCK NUMBER	FIG.	ITEM
04713	MR508	5961-01-033-9376	6	7
04713	MR811	5961-01-072-9781	8	29
96906	MS14151-2	5310-01-077-1565	3	14
96906	MS14151-2	5310-01-077-1565	18	109
96906	MS16555-20	5315-00-959-6762	18	7
96906	MS16555-40	5315-00-811-6495	18	8
96906	MS16555-53	5315-00-927-9893	3	30
96906	MS16555-55	5315-00-836-1422	18	9
96906	MS16555-60	5315-00-820-8051	18	10
96906	MS16562-36	5315-00-810-3701	17	22
96906	MS16624-1025	5365-00-720-8064	18	106
96906	MS16624-1025	5365-00-720-8064	21	5
96906	MS16625-1090	5365-00-808-0645	18	64
96906	MS16625-4102	5365-00-805-1401	12	55
96906	MS16626-1100	5365-00-281-9885	4	1
96906	MS16626-1100	5365-00-281-9885	5	9
96906	MS16629-1056	5365-00-347-8254	12	30
96906	MS16697-33	. . .	6	19
96906	MS16997-18	5305-00-978-9346	21	2
96906	MS16997-21	5305-00-978-9349	7	30
96906	MS16997-22	5305-00-978-9350	7	29
96906	MS16998-19	5305-00-052-8250	11	33
96906	MS16998-29	5305-00-983-6652	18	33
96906	MS16998-29	5305-00-983-6652	21	41
96906	MS 16998-30	5305-00-983-6653	3	50
96906	MS171434	5315-01-116-6789	2	14
96906	MS172206	5310-00-619-6446	18	102
96906	MS172241	5310-00-515-7592	18	103
96906	MS17795-103	3120-00-970-4623	18	29
96906	MS19060-4812	3110-00-838-5033	2	9
96906	MS20002C6	5310-00-149-9146	1	2
96906	MS20066-117	5315-00-732-2841	3	22
96906	MS20066-234	5315-00-729-6991	18	75
96906	MS20068-53	5315-00-990-6023	18	76
96906	MS20392-5C71	5315-00-959-5500	17	18
96906	MS20426DD2-8	5320-00-233-4800	14	8
96906	MS20426DD4-6	5320-00-117-7208	11	17
96906	MS20427F4-5	5320-00-243-3933	17	7
96906	MS20613-4C14	5320-00-990-2844	18	92
82402	MS20613-4C20	5320-00-881-6193	23	2
96960	MS20659-111	5940-00-115-2678	6	57
96906	MS20659-130	5940-00-114-1316	6	75
96906	MS20659-138	5940-00-113-3136	7	5
96906	MS20659-144	5940-00-115-2677	6	58
96906	MS21042-3	5310-00-807-1467	3	51
96906	MS21042LO6	5310-00-807-1472	7	35
96906	MS21042LO6	5310-00-807-1472	8	18
96906	MS21042LO6	5310-00-807-1472	8	63

PART NUMBER INDEX (coat)

FSCM	PART NUMBER	STOCK NUMBER	FIG.	ITEM
96906	MS21042L06	5310-00-807-1472	13	31
96906	MS21042L08	5310-00-807-1473	6	23
96906	MS21042L08	5310-00-807-1473	11	47
96906	MS21042L/4	5310-00-807-1475	7	19
96906	MS21044N3	5310-00-877-5797	11	96
96906	MS21045-3	5310-00-061-7326	3	36
96906	MS21045-3	5310-00-061-7326	3	48
96906	MS21045-L04	5310-00-857-5558	12	34
96906	MS21083B3	5310-00-905-8434	6	35
96906	MS21083B5	5310-00-905-8434	6	29
96906	MS21083B6	5310-00-926-5832	6	32
96906	MS21083D08	5310-00-941-6440	21	35
96906	MS21083D3	5310-00-905-3081	21	12
96906	MS21083N06	5310-00-905-8451	19	50
96906	MS21083N08	5310-00-941-6019	11	75
96906	MS21083N3	5310-00-902-6676	1	14
96906	MS21083N3	5310-00-902-6676	1	21
96906	MS21083N3	5310-00-902-6676	18	14
96906	MS21090-0414	5305-00-132-1497	6	12
96906	MS21090-0414	5305-00-132-1497	6	68
96906	MS21090-0414	5305-00-132-1497	6	99
96906	MS21090-06001	5305-00-052-1488	6	14
96906	MS21090-0623	5305-00-459-1172	6	91
96906	MS21090-0623	5305-00-459-1172	19	41
96906	MS21096-04001	5305-01-073-5052	6	77
96906	MS21096-06001	5305-01-052-1488	6	25
96906	MS21096-06001	5305-01-052-1488	6	73
96906	MS21096-06001	5305-01-052-1488	8	3
96906	MS21096-06002	5305-01-066,1860	6	79
96906	MS21096-06003	5305-01-073-3636	6	63
96906	MS21096-06003	5305-01-073-3636	6	87
96906	MS21096-06003	5305-01-073-3636	8	2
96906	MS21096-08001	5305-00-182-9570	6	18
96906	MS21096-08001	5305-00-182-9570	6	84
88044	AN742H4	5340-00-558-5323	1	12
88044	AN742H4	5340-00-558-5323	3	70
96906	MS21209C0615P	5340-01-047-8340	21	51
96906	MS21209C0815P	5340-01-035-4121	21	52
96906	MS21209F0815	5340-00-324-9146	11	90
96906	MS21250-06006	5306-00-975-2073	1	7
96906	MS21295-16	5305-00-869-1097	6	39
96906	MS21295-22	5305-00-931-8601	6	40
96906	MS21295-36	5305-00-052-7004	6	42
96906	MS21318-7	3505-00-253-5606	1	10
96096	MS21318-7	3505-00-253-5606	2	31
96906	MS21318-7	3505-00-253-5606	3	53
96906	MS21318-7	3505-00-253-5606	11	25
96906	MS21318-7	3505-00-253-5606	12	57

PART NUMBER INDEX (cont)

FSCM	PART NUMBER	STOCK NUMBER	FIG.	ITEM
96906	MS21318-7	3505-00-253-5606	18	154
96906	MS21333-69	5340-00-764-7051	3	71
96906	MS21333-69	5340-00-764-7051	21	32
96906	MS21333-69	5340-00-764-7051	21	34
96906	MS21333-71	5340-00-057-2904	1	18
96906	MS21333-71	5340-00-057-2904	3	72
96906	MS24660-23D	5930-00-847-2599	6	96
96906	%X324665- 134	5315-00-839-5820	18	88
96906	MS24665-134	5315-00-839-5820	22	2
96906	MS24665-281	5315-00-839-2326	3	61
96906	MS24665-283	3515-00-842-3044	17	17
96906	MS24665-359	3515-00-013-7214	11	64
96906	MS24678-11	5305-00-680-0543	19	1
96906	MS24678-11	5305-00-680-0543	19	54
96906	MS24693-24	5305-01-031-1020	14	12
96906	MS24693-B25	5305-01-084-4655	2	2
96906	MS24693-S24	5305-00-957-7816	11	58
96906	MS24693-S25	5305-00-051-6521	11	85
96906	MS24693-S36	5365-00-771-0522	13	30
96906	MS24693C295	5305-00-709-2013	18	69
96906	MS24694C49	5305-00-824-2024	3	85
96906	MS25036-101	5940-00-813-0698	6	1
96906	MS25036-101	5940-00-813-0698	7	38
96906	MS25036-101	5940-00-813-0698	10	13
96906	MS25036-101	5940-00-813-0698	12	31
96906	MS25036-103	5940-00-143-4771	6	3
96906	MS25036-106	5940-00-283-5280	7	47
96906	MS25036-108	5940-00-143-4780	6	4
96906	MS25036-149	5940-00-557-1629	6	2
96906	MS25036-149	5940-00-557-1629	21	33
96906	MS25036-154	5940-00-230-0515	7	46
96906	MS25041-10	6120-00-818-0230	6	16
96906	MS25041-2-327	- - -	2	4
96906	MS25041-4-327	6210-00-939-7609	2	3
96906	MS25082B4	5310-00-822-2077	7	17
96906	MS25082S3	5310-00-165-1886	8	10
96906	MS25237-327	6240-00-155-7836	6	15
96906	MS25281-F3	5310-00-998-0611	8	60
96906	MS25281-F6	5340-00-915-2342	8	11
96906	MS25306-222	5930-00-728-4328	6	108
96906	MS27183-4	5310-00-950-1310	12	33
96906	MS27217-1	5930-00-824-9433	2	6
96906	MS27400-9	5945-01-020-5009	6	70
96906	MS27641-20	3110-00-027-8143	15	15
96906	MS27646-38	3110-00-106-8823	16	3
96906	MS27769-2	4730-00-278-3462	18	46
96906	MS28774-011	5330-00-582-1548	18	62
96906	MS28775-010	5330-00-584-0266	3	10

PART NUMBER INDEX (cont)

<u>FSCM</u>	<u>PART NUMBER</u>	<u>STOCK NUMBER</u>	<u>FIG.</u>	<u>ITEM.</u>
96906	MS28775-012	5330-00-584-0265	3	79
96906	MS28775-013	5330-00-684-3420	3	23
96906	MS28775-016	5330-00-684-3419	23	14
96906	MS28775-023	5330-00-727-2637	23	12
96906	MS28775-111	5330-00-579-8108	12	3
96906	MS28775-126	5330-00-702-1048	19	3
96906	MS28775-133	5330-00-802-2130	11	5
96906	MS28775-156	5330-01-071-0432	3	8
96906	MS28775-238	5330-00-579-7545	11	31
96906	MS28782-20	5330-00-171-9225	18	111
96906	MS3116E18-32S	5935-00-755-3630	9	67
96906	MS312E14-12P	5935-00-903-0038	11	1
96906	MS3126F10-6P	5935-00-726-6519	3	62
96906	MS33674-9	5975-00-727-5153	6	5
96906	MS3367-5-9	5975-00-727-5153	6	6
96906	MS3420-16	5365-00-141-6943	19	43
96906	MS3470W10-65	5935-01-107-8827	6	98
96906	MS3470W12-8S	5935-01-107-8830	6	104
96906	MS3470W18-32P	5935-01-107-8855	6	76
96906	MS3472W14-12S	5935-01-170-0019	6	101
96906	MS3472W14-19S	5935-01-124-8514	2	27
96906	MS35058-22	5930-00-655-1514	6	105
96906	MS35190-224	5305-00-958-6230	10	14
96906	MS35190224	5305-00-958-6230	12	32
96906	MS35190-269	5305-00-957-6272	10	1
96906	MS35206-203	5305-00-889-3118	7	43
96906	MS35206-212	5305-00-993-0191	11	61
96906	MS35206-213	5305-00-889-3116	11	60
96906	MS35206-226	5305-00-984-4983	11	53
96906	MS35206-229	5305-00-9844989	8	16
96906	MS3520-231	5305-00-889-3001	8	59
96906	MS35206-234	5305-00-984-6221	19	48
96906	MS35206-240	5305-00-984-6226	10	34
96906	MS35206-246	5305-00-984-6194	6	47
96906	MS35206-327	5305-00-993-5767	8	15
96906	MS35206-327	5305-00-993-5767	8	61
96906	MS35207-261	5305-00-990-6444	11	8
96906	MS35207-263	5305-00-989-7434	3	13
96906	MS35207-266	5305-00-995-3444	3	15
96906	MS35207-268	5305-00-995-3442	18	110
96906	MS35215-75	5305-00-954-9010	7	23
96906	MS35265-1	5305-00-559-8144	10	5
96906	MS35265-19	5305-00-614-0261	12	15
96906	MS35265-2	5305-00-579-2138	12	2
96906	MS35265-26	5305-00-514-7506	19	31
96906	MS35265-4	5305-00-614-0286	2	11
96906	MS35265-46	5305-00-622-9476	21	10
96906	MS35265-50	5305-00-622-9479	11	46

PART NUMBER INDEX (cont)

FSCM	PART NUMBER	STOCK NUMBER	FIG.	ITEM
96906	MS35265-52	5305-00-151-0376	11	49
96906	MS35265-52	5305-00-151-0376	11	73
96906	MS35265-7	5305-00-614-0288	2	7
88044	MS35266-63	5305-00-614-0246	1	13
88044	MS35266-63	5305-00-614-0246	1	19
96906	IvIS35266-65	5305-00-616-4831	18	19
96906	MS35266-66	5305-00-614-0248	18	12
96906	MS35333-38	5310-00-559-0070	10	33
96906	MS35338-100	5310-00-261-8278	6	41
96906	MS35338-100	5310-00-261-8278	8	9
96906	MS35338-101	5310-00-184-8970	7	20
96906	MS35338-43	5310-00-045-3296	6	34
96906	MS35338-45	5310-00-407-9566	6	31
96906	MS35338-46	5310-00-004-5033	6	28
96906	MS35338-98	5310-00-184-8977	6	61
96906	MS35338-98	5310-00-184-8977	7	31
96906	MS35338-98	5310-00-184-8977	8	17
96906	MS35338-99	5310-00-576-0546	6	22
96906	MS35338-99	5310-00-576-0546	6	60
96906	MS35430-4	5940-00-681-8185	2	26
96906	MS35489-38	5325-00-582-3601	21	53
96906	MS35648-12	5340-00-054-1408	17	11
96906	MS35649-265	5310-00-934-9763	8	21
96906	MS35649-282	5310-00-934-9757	6	48
96906	MS35649-286	5310-00-934-9762	6	21
96906	MS35756-3	5315-00-687-5218	4	7
96906	MS35756-3	5315-00-687-5218	5	3
96906	MS35756-3	5315-00-687-5218	18	159
96906	MS51830-201L	5340-00-021-3495	3	57
96906	MS51830-202	5340-00-085-0219	3	58
96906	MS51830-202	5340-00-085-0219	18	25
96906	MS51830-204L	5340-00-783-9139	18	5
96906	MS51838-93	5315-01-077-7289	18	80
96906	MS51857-9	5305-00-054-5643	3	86
96906	MS51957-13	5305-00-054-5647	2	25
96906	MS51957-14B	5305-00-459-4687	2	28
96906	MS51957-43	5305-00-054-6668	2	18
96906	MS51957-9	5305-00-054-5643	11	37
96906	MS51957-9	5305-00-054-5643	11	78
96906	MS51957-9	5305-00-054-5643	21	48
96906	MS51959-4	5305-00-764-2964	2	16
96906	MS51960-65	5305-00-071-1322	3	19
96906	MS51973-112	5305-01-088-0263	11	7
96906	MS51977-20	5305-00-058-9363	2	21
96906	MS9015-02	5365-00-289-3073	3	11
96906	MS9015-08	5365-00-289-3070	18	152
96906	MS9048-112	5315-00-584-9221	17	20
96906	MS9068-044	5330-00-940-9475	19	39

PART NUMBER INDEX (cont)

FSCM	PART NUMBER	STOCK NUMBER	FIG.	ITEM
96906	MS9486-50	5315-00-139-7064	22	13
96906	MS9841-06	5315-00-143-9681	18	93
98628	MV83523TS446V	5340-01-073-1579	18	36
08289	MW-296-140	5970-01-130-2134	8	19
08289	MW-562-203-002	5310-01-007-6897	8	7
79136	N5001-56MD	5365-00-347-8254	10	8
80205	NAS1103-44	5306-00-816-0117	3	82
80205	NAS1252-10L	5310-00-819-5413	3	7
80205	NAS1304-18	5306-00-818-7516	18	44
80205	NAS1351-3-10P	5305-00-058-0505	11	95
80205	NAS1352-06H8	5305-00-934-0114	11	42
80205	NAS1352-08H4	5305-00-308-9735	11	22
80205	NAS1394C3	5340-00-973-6933	18	21
80205	NAS1394C3L	5340-00-021-3495	11	11
80205	NAS1394C3L	5340-00-021-3495	18	2
80205	NAS1394C3L	5340-00-021-3495	18	26
80205	NAS1394G4L	5340-00-085-0219	3	69
80205	NAS1394C4L	5340-00-085-0219	18	3
80205	NAS1394C5L	5340-00-9%5909	18	4
80205	NAS1394CA3	5340-00-471-3745	18	16
80205	NAS1395C06	5340-00-995-6690	18	6
80205	NAS1593-013	5330-01-076-5704	18	121
80205	NAS1593-133	5330-00-970-2710	18	160
80205	NAS1593-152	5330-01-095-5739	18	52
80205	NAS1595-8	5330-00810-9659	18	131
80205	NAS1595-8	5330-00-810-9659	18	151
80205	NAS43DD1-16	5365-00-302-8098	11	40
80205	NAS620-10L	5310-00-680-7296	3	35
80205	NAS620-2	5310-00-616-6791	7	42
80205	NAS620-6L	5310-00-616-6822	11	41
80205	NAS620-6L	5310-00-616-6822	11	79
80205	NAS620-8	5310-00-805-7632	18	28
80205	NAS620-8	5310-00-805-7632	18	30
80205	NAS620A2	5310-00-660-2084	3	87
80205	NAS620A416L	5310-00-655-7549	3	40
21355	PAMS1K7FS60160	3110-00-198-2050	3	33
77820	PC06E8-4SSR	5935-00-813-2020	18	149
12143	PT06SE12-8P(SR)	5935-00-730-9950	21	30
38443	R4A4ST0305A023H1 OX7296L	3110-00-186-1104	18	126
38443	R4ZZ	3110-00-017-8900	21	15
38443	R6ZZST03ST023H20	3110-00-710-4936	15	5
38443	R6ZZST03ST023H20	3110-00-710-4936	21	20
38443	R8ZZ	3110-00-782-0417	18	95
38443	R8ZZ	3110-00-782-0417	18	120
60380	RCB081214FS	3110-01-083-3260	4	9
60380	RCB081214FS	3110-01-083-3260	5	1
81349	RCRO7G1O2JS	5905-00-110-7620	9	30
81349	RCR.07G1O3JS	5905-00-106-3666	9	23

PART NUMBER INDEX (cont)

FSCM	PART NUMBER	STOCK NUMBER	FIG.	ITEM
81349	RCR07G185JS	5905-00-126-6710	9	42
81349	RCR07G202JS	5905-00-114-0708	9	29
81349	RCR07G203JS	5905-00-106-9356	9	39
81349	RCR07G222JS	5905-00-105-7764	9	52
81349	RCR07G223JS	5905-00-116-8556	9	56
81349	RCR07G272JS	5905-00-111-4727	9	22
81349	RCR07G331JS	5905-00-114-0710	9	38
81349	RCR07G332JS	5905-00-126-6683	9	31
81349	RCR07G472JS	5905-00-114-0711	9	25
81349	RCR07G512JS	5905-00-111-1679	9	33
81349	RCR07G681JS	5905-00-135-6046	9	21
81349	RCR07G682JS	5905-00-110-7622	9	34
81349	RCR2OG1O1JS	5905-00-106-9344	8	50
81349	RCR2OG1O2JS	5905-00-110-0196	8	40
81349	RCR2OG154JS	5905-00-106-9348	8	45
81349	RCR2OG201JS	5905-00-141-0727	8	41
81349	RCR2OG222JS	5905-00-141-1168	8	56
81349	RCR2OG273JS	5905-00-106-9351	8	55
81349	RCR2OG330JS	5905-00-935-8543	8	44
81349	RCR2OG393JS	5905-00-141-0599	8	51
81349	RCR2OG471JS	5905-00-111-4858	9	27
81349	RCR2OG471JS	5905-00-111-4858	9	32
81349	RCR2OG474JS	5905-00-141-1071	8	54
81349	RCR32G102JS	5905-00-121-9861	8	42
81349	RCR32G152JS	5905-00-106-1246	8	46
81349	RCR32G202JS	5905-00-246-9399	8	47
81349	RCR32G220JS	5905-00-247-8710	7	44
81349	RCR32G271JS	5905-00-247-8722	7	45
81349	RCR32G331JS	5905-00-228-6088	8	37
81349	RCR32G471JS	5905-00-247-8732	8	34
81349	RER65FIROOR	5905-00-211-1318	7	41
81349	RER65FR1OOR	5905-00-472-0790	7	40
81349	RER70F25ROR	- - -	6	107
81349	RER75F4R02R	5905-00-139-1989	6	67
81349	RER75G12R1R	5905-00-506-6606	6	66
81349	RNC60H1001FS	5905-00-197-4289	8	36
81349	RNC60H100FS	5905-00-197-4289	9	37
81349	RNC60H1002FS	5905-00-138-1283	9	24
81349	RNC60H1003FS	5905-00-407-2160	9	41
81349	RNC60H1272FS	5905-00-721-2341	9	55
81349	RNC60H2001FS	5905-00-403-3124	9	60
81349	RNC60H2052FS	5905-00-099-0479	9	53
81349	RNC60H2152FS	5905-00-043-3127	9	28
81349	RNC60H2213FS	5905-00-401-8689	9	47
81349	RNC60H2802FS	5905-00-165-3108	9	44
81349	RNC60H3832FS	5905-00-432-0464	9	35
81349	RNC60H3922FS	5905-00-721-2348	9	43
81349	RNC60H3923FS	5905-00-479-9952	9	50

PART NUMBER INDEX (cont)

FSCM	PART NUMBER	STOCK NUMBER	FIG.	ITEM
81349	RNC60H4492FS	5905-00-405-8355	9	58
81349	RNC60H4641FS	5905-00-146-4164	9	36
81349	RNC60H4751FS	5905-00-403-3147	9	59
81349	RNC60H4991FS	5905-00-194-8405	9	57
81349	RNC60H6191FS	5905-00-491-8744	9	46
81349	RNC60H6192FS	5905-00-481-3076	9	48
81349	RNC60H6651FS	5905-00-006-2978	9	49
81349	RNC60H6652FS	5905-00-758-3380	9	26
81349	RNC60H8062FS	5905-00-758-3388	9	54
81349	RNC60H9091FS	5905-00-006-5575	9	40
81349	RNC60H9532FS	5905-00-650-9814	9	45
80756	RR50C	5365-00-531-9454	13	10
80756	RRT106CK	5365-00-800-8270	16	7
80756	RRT118	5365-01-212-1437	16	6
98349	RST62	5365-00-272-5583	16	5
81349	RWP21F6800F		8	35
21335	AMS1K7	3110-00-159-9239	18	129
50891	SCSFIR	5961-01-081-4805	7	6
81349	SE096E02	5940-01-031-1027	6	80
81349	SE096E02	5940-01-031-1027	7	48
81349	SE16XC02	5940-01-962-0033	9	64
01226	SL375	5340-01-084-5152	11	9
83086	SR33PPK58-168	3110-00-191-3236	13	12
28520	SR5P4	5975-00-351-6114	12	4
43334	SS77038LR3053E9	3110-00-293-8889	10	21
24617	SS77R4XR3MILG327246178	- - -	12	38
97820	T087-1A	- - -	15	6
08289	TA2402A	5970-00-023-6246	7	36
82402	TA5000LH14HA	5340-01-075-2154	1	17
08289	TW-147-236-094N	5365-01-095-6882	7	32
08289	TW-147-236-094N	5365-01-095-6882	8	20
08289	TW-325-425-115N	5365-01-075-6445	7	10
08289	TW260-370-10OTS	5365-01-078-4121	7	25
82402	W0734-009	5310-00-087-3155	12	37
92830	W2420-025	5310-00-595-7484	13	33
07236	WA510	5365-00-285-6784	18	72
43334	Z993L03XR1DU4	3110-01-075-2082	19	10
12881	01-0504-1891	1680-01-070-7616	6	10
26916	058-001253	5962-00-593-6554	8	14
38443	102-KR	3110-00-156-5190	3	26
82402	10981-1	5305-01-071-7111	10	7
82402	10982	6105-01-213-5811	10	4
08866	1125C	5940-00-549-4444	8	38
82402	1209-10	6105-01-073-7452	12	39
82402	1209-5	2805-01-060-7633	10	19
82402	12554-3	- - -	10	28
82402	13437	5305-01-078-9529	13	26
82402	13561-23	- - -	19	21

PART NUMBER INDEX (cont)

FSCM	PART NUMBER	STOCK NUMBER	FIG.	ITEM
51506	136-093N 1	5365-01-133-6174	6	55
82402	13781-2	5365-01-072-2925	12	16
82402	1398-11	- - -	12	7
82402	1398-11	1680-01-071-0134	12	11
51506	140-01 5-N- 1	5365-01-133-0264	6	89
82402	14295	- - -	12	21
82402	14298	- - -	12	13
82402	14299	- - -	12	10
82402	14300	5360-01-080-2013	12	19
82402	14301	1680-01-070-5393	12	9
82402	14302	1680-01-070-9951	12	5
82402	14303	- - -	12	6
82402	14304-1	- - -	12	1
82402	145025	- - -	19	19
82402	145865	- - -	19	29
82402	146687	5310-00-988-0443	10	25
82402	146778	- - -	19	20
82402	14853	6105-00-407-3909	19	55
82402	149090	- - -	6	90
82402	149093	5310-01-198-2313	6	97
82402	149097	- - -	6	REF
82402	149099	- - -	10	2
82402	149101	- - -	19	2
82402	149102	- - -	19	5
82402	149104	- - -	19	6
82402	149105	- - -	19	32
82402	149106	- - -	19	13
82402	149110	5977-01-190-5526	19	56
82402	149111	- - -	6	REF
82402	149119	- - -	6	9
82402	149126	5150-01-154-9661	7	7
82402	149128	6625-01-150-3091	6	46
82402	149131	5950-01-102-3992	6	17
82402	149145	- - -	2	REF
82402	149146	- - -	2	29
00462	149148	1680-01-078-4181	2	22
82402	149150	1680-01-070-7561	2	19
82402	149152	3110-01-075-5287	2	10
82402	149154	5930-01-216-6525	2	24
82402	149155	1680-01-070-7560	2	15
82402	149156	1680-01-271-5299	2	1
82402	149161	7690-01-135-2985	6	93
82402	149163	1680-01-070-7559	2	8
82402	149192	7690-01-135-2086	6	94
82402	149224	3120-01-108-2420	2	17
82402	149304-1	5915-01-101-3888	6	26
82402	149470	6110-01-103-3121	6	64
82402	149540	5950-01-130-7660	6	24

PART NUMBER INDEX (cont)

FSCM	PART NUMBER	STOCK NUMBER	FIG. ITEM	
02111	152-79-00	5905-01-076-5608	2	13
82402	15205-1	5340-01-072-9343	10	9
82402	15205-1	5340-01-072-9343	12	29
82402	15205-2	5970-01-074-6856	10	10
82402	15205-2	5970-01-074-6856	12	27
82402	15205-3	5340-01-095-5668	10	11
82402	15208	- - -	12	22
82402	15250	2925-01-147-6688	10	27
82402	15255	5977-01-072-8312	12	23
82402	15433	6105-01-173-8768	10	6
82829	16BS100C7	5310-00-906-9552	19	37
82402	1700B67	5365-00-514-8291	18	65
82402	1706B59	5365-01-078-5625	15	4
38443	1902S	3110-00-868-2669	18	147
21335	1902S	3110-00-868-2669	22	15
38443	1903s	3110-00-180-7284	18	157
82402	19075	- - -	8	57
82402	19076-3	1680-01-147-6715	8	23
82402	19078	- - -	8	12
38448	1908S	3110-00-293-9605	18	114
82402	19136	- - -	12	42
82402	19158	6150-00-107-5410	12	20
82402	19204-1	- - -	12	47
82402	19208	- - -	6	38
82402	19210-1	- - -	6	37
82402	19214	5307-01-078-4001	7	16
82402	19215-3	1680-01-073-3358	6	13
82402	19221-3	5961-01-070-7629	6	11
82402	19221-3	5961-01-070-7629	7	REF
82402	19223	- - -	8	1
82402	19225-3	5999-01-071-9221	6	62
82402	19225-3	5999-01-071-9221	8	REP
82402	19230	- - -	6	81
82402	19233	5940-01-073-1877	7	1
82402	19234	1680-01-201-7836	6	78
82402	19236-1	1680-01-070-7555	6	82
82402	19236-3	1680-01-146-8059	6	83
82402	19240-1	1680-01-070-7554	6	44
82402	19240-2	1680-01-070-7558	6	43
82402	19241	5930-01-195-2113	6	109
82402	19246	1680-01-147-6716	6	86
82402	19246	1680-01-147-6716	9	REP
82402	19248	1680-01-231-4829	9	51
82402	19255-1	5961-01-195-0837	6	110
82402	19257	- - -	6	56
82402	19258-1	- - -	7	21
82402	19258-3	- - -	7	22
82402	19258-7	- - -	7	27

PART NUMBER INDEX (cont)

FSCM	PART NUMBER	STOCK NUMBER	FIG.	ITEM
82402	19261	6150-01-076-3918	6	51
82402	19262	6150-01-077-7519	6	52
82402	19263	6150-01-073-8442	7	26
82402	19283	- - -	12	58
82402	19515	6150-01-201-7837	10	29
82402	19693	1615-01-092-7962	19	45
82402	19695	1680-01-128-6330	19	46
82402	19773	1650-01-075-6505	19	51
82402	19774	- - -	19	52
82402	19775	1650-01-075-6551	19	57
82402	19776	5970-01-209-6142	19	47
82402	19777	6150-01-079-8863	19	30
82402	19781	1680-01-126-4128	19	40
82402	19840	- - -	12	46
82402	19840-1	- - -	12	48
82402	19852	3120-01-077-1610	12	49
82402	19856	- - -	12	56
82402	19948	5935-01-071-0348	19	42
27014	1N4742A	5961-00-018-9196	8	52
27014	1N4751A	5961-00-018-9196	8	28
91929	ISE2	5930-00-553-5920	11	76
91929	1SE2	5930-00-917-7083	21	45
91929	1SE2-3	5930-00-729-1662	21	44
91929	1SE2-6	5930-00-137-1511	11	38
02697	2-1 11V747-75	5330-01-048-5000	18	47
23172	2171	6145-00-728-4026	10	3
82402	21722	- - -	12	41
82402	21723	5950-01-074-8739	12	44
82402	21724	5950-01-076-1253	12	12
82402	21725	5950-01-074-8740	12	14
82402	21811	6105-01-076-6582	19	15
82402	21812	- - -	19	16
00462	21875	6105-01-195-3330	10	26
82402	21877	- - -	19	12
72962	21NE058	5310-00-158-5280	7	14
22599	22NTM-40	5310-00-956-0054	10	16
82402	239YC32	6105-01-071-5413	11	45
82402	239YC32	6105-01-071-5413	12	REF
82402	239YC33	6105-01-070-7615	10	REF
82402	2518	- - -	12	43
83330	2665	5310-00-998-5039	6	54
56878	28420- 156A8	5315-01-091=1413	15	7
80131	2N3741A	5961-01-007-5842	8	27
04713	2N4912	5961-00-127-9362	8	26
04713	2N5682	5961-01-016-9906	9	3
04713	2N6049	5691-00-262-0814	7	28
09213	3120GE243U050APA1	5910-01-212-1423	6	45
82402	31530-1	5315-01-075-0941	13	17

PART NUMBER INDEX (cont)

FSCM	PART NUMBER	STOCK NUMBER	FIG.	ITEM
82402	31530-1	5315-01-075-0941	13	23
82402	31531	3020-01-070-2521	13	16
82402	31531	3020-01-070-2521	13	21
82402	31546	5315-01-071-8271	13	9
82402	31547	3020-01-070-4579	13	11
15605	32-341	---	6	59
82402	32160	---	12	8
32997	3252-W-1-102	5905-01-043-6849	9	61
32997	3252-W-1-103	5905-01-008-6215	9	62
32997	3252-W-1-501	5905-01-027-8321	9	63
00779	34103	5940-01-050-7460	7	6
82402	36274	6105-01-076-1301	12	40
82402	36346	---	19	26
82402	36391	1680-01-070-7557	13	8
82402	36391	1680-01-070-7557	3	15
82402	36392	---	13	14
82402	36397	---	13	7
82402	36410	---	19	22
82402	36609	---	19	24
82402	36610-1	---	19	5
82402	36611	---	19	27
82402	36782	6105-01-173-2093	10	20
00462	36786	6105-01-075-6679	19	18
82402	36787	---	19	23
43334	3L00	3110-00-554-5389	12	51
13103	4003	5970-00-258-2313	7	39
96214	400859	5930-00-258-4624	2	23
06540	9226N140	5365-00-111-7417	7	4
82402	4067C193	5110-00-918-3027	3	90
82402	4067C193	5110-00-918-3027	11	36
82402	4067C193	5110-00-918-3027	11	77
82402	4067C193	5110-00-918-3027	21	47
53217	42-81496	5330-01-215-7137	6	36
53127	42-81652	5990-01-195-1989	6	100
53127	42-81654	5990-01-144-5239	6	103
53127	42-81656	5999-01-143-8453	6	102
82402	42217C88	---	15	12
82402	42217C93	5310-01-006-9021	15	9
82402	42217087	3020-00-575-2897	15	10
82402	42217089	1680-01-030-9357	15	8
82402	422340167	1680-00-020-8325	18	67
82402	422340178	1680-00-768-9670	18	56
82402	422340179	1680-00-091-6645	18	85
82402	422340220	3110-00-147-1155	3	64
82402	422340402	1680-00-001-6850	23	11
82402	422340405	1680-00-497-7491	23	15
82402	42234052	1680-00-001-5314	18	68
82402	42234052	1680-00-001-5314	18	82

TM 55-1680-320-23&P
 NATIONAL STOCK NUMBER INDEX (cont)

FSCM	PART NUMBER	STOCK NUMBER	FIG.	ITEM
82402	42234D54	1680-00-020-9478	18	66
82402	42234D65	5365-00-021-1729	18	74
82402	42234D85	1680-00-769-0425	18	27
82402	42234D97	5305-00-001-5326	18	73
82402	42234E56	1680-00-742-1671	18	71
82402	42234R182-1	- - -	18	31
00462	42277-308	- - -	3	80
82402	42277-360	5330-01-193-0318	3	24
82402	42277-716	- - -	24	1
82402	42277-728	- - -	24	5
82402	42277-730	- - -	24	3
82402	42277-808	- - -	24	2
82402	42277C149	5365-01-058-5631	21	29
82402	42277C150	5365-01-068-8553	18	144
82402	42277C150	5365-01-068-8553	21	26
82402	42277C155	5365-01-068-5632	21	8
82402	42277C175	3020-01-071-2843	18	107
82402	42277C195	5365-01-071-2386	18	127
82402	42277C214	1680-01-070-0991	18	48
82402	42277C216	5365-01-070-2807	18	55
82402	42277C221	9905-01-086-4517	3	54
82402	42277C221	9905-01-086-4517	18	153
82402	42277C228	5365-01-105-7114	21	49
82402	42277C244	5330-01-095-3724	18	117
82402	42277C286	3120-01-078-2842	23	3
82402	42277C314	1680-01-078-6059	4	2
82402	42277C314	1680-01-078-6059	5	8
82402	42277C315	1680-01-070-7727	4	4
82402	42277C315	1680-01-070-7727	5	6
82402	42277C326	5365-01-075-7741	3	25
82402	42277C341	5315-01-075-2126	3	41
82402	42277C342	5365-01-072-9358	3	45
82402	42277C344	5305-01-074-1462	3	75
82402	42277C346	5315-01-073-2976	3	38
82402	42277C349	5310-01-073-9225	4	5
82402	42277C349	5310-01-073-9225	5	5
82402	42277C351	- - -	3	3
82402	42277C352	1680-01-071-5375	3	44
82402	42277C366	5930-01-089-1281	3	49
82402	42277C370	5310-01-151-1708	3	59
82402	42277C517	1680-01-070-9965	17	9
82402	42277C518	5310-01-073-2948	17	10
82402	42277C546	1680-01-070-9959	14	11
82402	42277C576	5315-01-162-5032	17	13
82402	42277C584	5310-01-073-2949	17	16
82402	42277C610	5365-01-071-3639	13	32
82402	42277C615	1680-01-070-0988	13	3
82402	42277C704	- - -	6	95
82402	42277D121	3040-01-072-4524	18	138

PART NUMBER INDEX (cont)

FSCM	PART NUMBER	STOCK NUMBER	FIG.	ITEM
82402	42277D124	3110-01-078-5025	18	101
82402	42277D130	3020-01-072-3615	18	96
82402	42277D131	3020-01-076-3464	18	84
82402	42277D137	1680-01-146-0888	18	89
82402	42277D139	5365-01-071-8480	18	91
82402	42277D139	5365-01-071-8480	18	94
82402	42277D140	1680-01-082-7811	21	16
82402	42277D146	3110-01-069-4978	21	22
82402	42277D151	1680-01-082-9696	21	40
82402	42277D153	1680-01-082-9700	21	1
82402	42277D156	3020-01-068-1568	18	104
82402	42277D156	3020-01-068-1568	21	7
82402	42277D158	1680-01-067-3100	21	23
82402	42277D160	1680-01-070-1214	22	9
82402	42277D165	1680-01-070-0965	18	143
82402	42277D167	1680-01-070-0992	18	122
82402	42277D179	5930-01-073-8884	18	150
82402	42277D181	1680-01-070-0990	18	81
82402	42277D185	1680-01-082-9695	21	27
82402	42277D197	5306-01-125-5446	21	24
82402	42277D215	3110-31-07804983	22	7
82402	42277D217	1680-01-077-6897	18	51
82402	42277D223	3020-01-068-2101	21	18
82402	42277D284	1680-01-070-1190	23	13
82402	42277D285	1680-01-070-0976	23	1
82402	42277D288	5360-01-072-1353	23	4
82402	42277D289	5365-01-071-3929	23	9
82402	42277D291	1680-01-072-1481	23	8
82402	42277D293	5340-01-105-7110	23	5
82402	42277D313	1680-01-070-9952	3	92
82402	42277D313	1680-01-070-9952	4	REF
82402	42277D317	1680-01-201-7835	4	8
82402	42277D317	1680-01-201-7835	5	2
82402	42277D318	1680-01-022-5788	3	17
82402	42277D318	1680-01-022-5788	5	REF
82402	4227D320	1680-01-071-5376	3	28
82402	42277D322	1680-01-071-5377	3	18
82402	42277D330	1680-01-160-6033	3	39
82402	42277D335	3020-01-076-0566	3	32
82402	42277D343	1680-01-071-9211	3	88
82402	42277D347	1680-01-071-5839	4	3
82402	42277D348	1680-01-071-0210	5	7
82402	42277D353	1680-01-071-5392	3	91
82402	42277D354	5365-01-072-2926	3	67
82402	42277D356	1680-01-071-5373	3	21
82402	42277D359	3040-01-070-5122	3	37

PART NUMBER INDEX (cont)

FSCM	PART NUMBER	STOCK NUMBER	FIG.	ITEM
82402	42277D369	1680-01-070-9955	3	63
82404	42277D516	1680-01-070-9966	17	6
82402	42277D523	1680-01-071-5380	11	15
82402	42277D528-5	- - -	11	10
82402	42277D544	3020-01-071-2908	14	4
82402	42277D550	1680-01-070-9961	14	9
82402	42277D551	1680-01-070-9960	14	10
82402	42277D557	1680-01-070-9962	15	
82402	42277D577	1680-0-083-3414	11	35
82402	42277D587	5340-01-089-4259	11	66
82402	42277D591	1680-01-072-5919	11	70
82402	42277D597	- - -	11	REF
82402	42277D598	5340-01-106-3690	11	21
82402	42277D602	3020-01-698-8854	13	29
82402	42277D604	3020-01-079-3138	13	2
82402	42277D605	1680-01-070-0987	13	1
82402	42277D607	1680-01-099-6315	17	8
82402	42277D616	1680-01-070-0989	13	19
82402	42277D617	- - -	13	20
82402	42277E112	1680-01-068-3035	18	20
82402	42277E112-1	- - -	18	22
82402	42277E117	3020-01-068-1506	18	115
82402	42277E118	- - -	18	79
82402	42277E125	3020-01-069-8447	18	98
82402	42277E138	1680-01-071-5392	18	90
82402	42277E144	3020-01-068-1504	21	19
82402	42277E145	3020-01-068-1505	21	9
82402	42277E166	1680-01-070-0967	18	128
82402	42277E168	1680-01-070-1188	18	108
82402	42277E180	1680-01-070-0993	18	77
82402	42277E182	1377-01-073-3831	3	74A
82402	42277E183	1680-01-070-0975	18	118
82402	42277E184	1680-01-070-0974	18	83
82402	42277E194	1680-01-071-9545	1	25
82402	42277E198	3020-01-078-6108	8	136
82402	42277E206	1680-01-070-0973	18	57
82402	42277E210	1680-01-070-0966	18	53
82402	42277E327	3020-01-073-9890	3	43
82402	42277E332	1680-01-071-5374	3	81
82402	42277E336	1377-01-087-5166	3	74
82402	42277E339-5	- - -	3	12
82402	42277E358	5360-01-026-0217	3	83
82402	42277E362	3020-01-070-8559	3	31
82402	42277E368	1680-01-077-6896	3	84
82402	42277E513	1680-01-070-7724	17	3
82402	42277E539	1680-01-071-0176	11	19
82402	42277E542	- - -	14	15
82402	42277E556	- - -	15	1

PART NUMBER INDEX (cont)

FSCM	PART NUMBER	STOCK NUMBER	FIG.	ITEM
82402	42277E559	3040-01-071-2902	15	18
82402	42277E594	1680-01-071-0178	11	3
82402	42277E596	5330-01-301-8843	11	21
82402	42277E600	1680-01-070-0969	11	48
82402	42277E600	1680-01-070-0969	13	REF
82402	42277E601	1680-01-070-0968	13	28
82402	42277E603	- - -	13	27
82402	42277R110	1615-01-147-6639	18	1
82402	42277R110-1	- - -	18	11
82402	42277R111	1680-01-077-6892	18	15
82402	42277R111-1	- - -	18	18
82402	42277R115	1680-01-146-0887	18	23
82402	42277R196	- - -	21	50
82402	42277R310-1	- - -	3	60
82402	42277R310-5	- - -	3	55
82402	42277R311-1	- - -	3	2
82402	42277R311-5	- - -	3	1
82402	42277R312-5	- - -	3	68
82402	42277R521	- - -	11	13
82402	42277R522	- - -	11	12
82402	42277R578	1680-01-071-9215	11	32
82402	42305-613	5340-01-226-0514	11	9
82402	42305-614	5340-01-225-3954	11	23
82402	42305-615	- - -	11	94
82402	42305C114	5315-01-072-9585	18	42
82402	42305C12	- - -	1	11
82402	42305C122	5310-01-069-0525	21	39
82402	42305C148	3120-01-074-7510	18	60
82402	42305C173	9905-01-155-8332	18	155
82402	42305C229	9905-01-122-2121	1	9
82402	42305C234	3120-01-072-9236	20	3
82402	42305C243	5310-01-303-1579	20	5
82402	42305C350	- - -	3	52
82402	42305C41	5365-01-106-4280	1	4
82402	42305C515	5340-01-132-8945	17	14
82402	42305C533	5310-01-077-1029	11	65
82402	42305C534	- - -	11	24
82402	42305C721	- - -	2	30
82402	42305D119	1680-01-099-6309	18	130
82402	42305D128	1680-01-076-4802	18	156
82402	42305D179	4010-01-168-0123	18	70
82402	42305D186	1680-01-082-9701	21	28
82402	42305D190	3020-01-069-9243	22	10
82402	42305D211	3040-01-072-4387	18	58
82402	42305D219	1680-01-070-9977	22	6
82402	42305D230	- - -	20	7

PART NUMBER INDEX (cont)

FSCM	PART NUMBER	STOCK NUMBER	FIG.	ITEM
82402	42305D231	5360-01-074-7823	20	8
82402	42305D232	1680-01-078-6045	20	6
82402	42305D235	1680-01-071-5517	20	4
82402	42305D238	1680-01-071-5516	20	9
82402	42305D287	1680-01-070-0970	23	7
82402	42305D290	1680-01-082-1130	23	16
82402	42305D30	- - -	1	8
82402	42305D372	1680-01-099-6310	3	9
82402	42305D519	1680-01-070-9976	11	71
82402	42305D528	1680-01-212-1385	11	4
82402	42305D528	1680-01-212-1385	16	REF
82402	42305D537	1680-01-087-9443	11	52
82402	42305D545	3020-01-071-2905	14	2
82402	42305D547	1680-01-070-9957	14	6
82402	42305D553	3120-01-137-9069	11	89
82402	42305D563	1680-01-070-9958	14	5
82402	42305D564	1680-01-070-9956	14	7
82402	42305D567	5315-01-105-9202	11	91
82402	42305D569	5307-01-080-2270	17	23
82402	42305D573	5340-01-135-2525	11	82
82402	42305D574	- - -	11	84
82402	42305D585	1680-01-071-9669	11	55
82402	42305D599	- - -	11	86
82402	42305D608	5360-01-105-7037	17	15
82402	42305D711	1680-01-102-8760	1	5
82402	42305E127	1680-01-070-1189	18	133
82402	42305E132	1680-01-070-0986	18	162
82402	42305E132	1680-01-070-0986	20	REF
82402	42305E143	1680-01-071-5515	18	34
82402	42305E159	3020-01-078-1069	18	158
82402	42305E200	1680-01-070-0977	18	63
82402	42305E200	1680-01-070-0977	22	REF
82402	42305E203	1680-01-075-2219	22	1
82402	42305E213	1680-01-070-0972	18	50
82402	42305E222	3020-01-069-6912	18	148
82402	42305E225	9905-01-086-0452	21	4
82402	42305E236	1680-01-073-3842	20	10
82402	42305E237	1680-01-071-0174	20	1
82402	42305E237-1	- - -	20	2
82402	42305E280	1680-01-070-0971	18	163
82402	42305E280	1680-01-070-0971	23	REF
82402	42305E281	4030-01-071-0121	23	6
82402	42305E42	1680-01-112-2944	1	3
82402	42305E502	1680-01-075-2222	15	14
82402	42305E510	1680-01-070-9974	11	81
82402	42305E510	1680-01-070-9974	17	REF
82402	42305E511	1680-01-070-7725	17	1
82402	42305E512	1680-01-212-1386	17	2

PART NUMBER INDEX (cont)

FSCM	PART NUMBER	STOCK NUMBER	FIG.	ITEM
82402	42305E514	1680-01-070-7546	17	4
82402	42305E514-1	- - -	17	5
82402	42305E526	- - -	16	1
82402	42305E531	- - -	11	68
82402	42305E532	- - -	11	69
82402	42305E535	1680-01-071-0177	11	83
82402	42305E536	1680-01-071-5390	11	67
82402	42305E540	1680-01-075-2234	11	50
82402	42305E540	1680-01-075-2234	14	REF
82402	42305E552	1680-01-071-5379	14	14
82402	42305E554	1680-01-072-1731	11	56
82402	42305E555	1680-01-070-9963	11	51
82402	42305E555	1680-01-070-9963	15	REF
82402	42305E558	- - -	15	17
82402	42305E561	1680-01-070-9964	11	63
82402	42305E561	1680-01-070-9964	17	12
82402	42305E562	---	14	REF
82402	42305E566	1680-01-111-0186	16	2
82402	42305E571	1680-01-099-6311	11	72
82402	42305E572	1680-01-099-6312	11	57
82402	42305E590	5307-01-223-3184	11	92
82402	42305E591	---	11	93
82402	42305E592	1680-01-099-6314	11	43
82402	42305E593	1680-01-075-2221	11	87
82402	42305E593-1	---	11	88
82402	42305E594	---	11	98
82402	42305E710	1680-01-082-8321	1	23
82402	42305E720	1680-01-070-7556	1	24
82402	42305E720	1680-01-070-7556	2	REF
82402	42305E724	9905-01-157-0836	6	65
82402	42305E730	1680-01-122-3580	1	16
82402	42305R1	1680-01-058-3671	1	REF
82402	42305R11	8145-01-076-7476	1	REF
82402	42305R100	1680-01-089-4331	1	31
82402	42305R100	1680-01-089-4331	18	REF
82402	42305R113	---	18	41
82402	42305R113-1	---	18	43
82402	42305R142	---	18	38
82402	42305R220	1680-01-082-9699	18	32
82402	42305R220	1680-01-082-9699	21	REF
82402	42305R300	1680-01-070-9953	1	6
82402	42305R300	1680-01-070-9953	3	REF
82402	42305R500	1680-01-070-9950	1	32
82402	42305R500	1680-01-070-9950	11	REF
82402	42305R530	---	11	26
82402	42305R530-1	---	11	27
82402	42305R565	---	11	28
82402	42305R568	1680-01-071-5389	11	59

TM 55-1680-320-23&P
PART NUMBER INDEX (cont)

FSCM	PART NUMBER	STOCK NUMBER	FIG.	ITEM
82402	42305R700	1680-01-070-0985	1	28
82402	42305R700	1680-01-070-0985	6	REF
82402	42325-212	5310-01-379-1125	22	11
82402	42325-228	5310-01-379-1169	22	12
82402	42325-255	1630-01-079-6644	22	8
82402	44191D192	- - -	24	4
82402	49001C10	5365-01-056-5073	21	21
82402	49001C12	5365-01-938-0138	18	119
82402	49001C36	5365-01-071-7559	18	146
82402	49001C42	5365-01-072-0192	3	27
82402	49001C6	5365-01-069-1803	3	34
82402	49001C6	5365-01-069-1803	21	25
82402	49001C8	5365-01-053-3337	18	125
82402	49001C8	5365-01-053-3337	18	142
82402	49001C8	5365-01-053-3337	18	145
82402	49001C8	5365-01-053-3337	22	14
82402	49001C82	5365-01-071-3640	18	113
82402	49001C82	5365-01-071-3640	18	140
82402	49002C39	5365-00-058-9557	4	6
82402	49002C39	5365-00-058-9557	5	4
82402	49003C10	5365-01-073-3033	15	16
82402	49008C3	5315-00-688-0373	18	105
82402	49008C3	5315-00-688-0373	21	6
82402	49008C99	- - -	22	5
82402	502R	5340-00-165-7832	1	26
05618	50334	5940-01-020-0872	7	3
82402	503R	5340-00-094-3554	1	27
08289	508-050-NY	5999-01-074-8839	9	66
79136	5100-18	5365-00-102-9261	13	13
82402	527KE3	6105-01-070-7614	18	37
82402	527KE3	6105-01-070-7614	19	REF
82402	5400	- - -	9	4
27014	5402	- - -	9	5
27014	5425	- - -	9	6
86928	5605-28	5970-00-144-7668	7	33
86928	5605-40	5310-00-478-9768	7	24
86928	5605-44	5310-00-479-4161	7	11
73680	71X7000	5330-00-285-4142	18	123
14304	755017A4021	5945-01-074-2661	6	50
04426	76-2190-404	5930-01-07806491	21	36
43334	77035LR1CJ3	3110-00-203-4097	10	18
14933	77043010B	- - -	9	7
43334	77R8XR1CJ3	- - -	13	25
82402	80177	1680-01-071-9665	19	4
82402	80177	1680-01-071-9665	19	53
82402	80181-2	- - -	19	28
82402	80192	3110-01-075-0830	19	38
82402	80200-2	- - -	12	25
82402	80200-2	- - -	19	17
82402	80314	5977-01-075-0901	10	12
82402	80326	5360-01-073-5416	2	20

PART NUMBER INDEX (cont)

FSCM	PART NUMBER	STOCK NUMBER	FIG.	ITEM
82402	80327	5930-01-074-8711	2	5
82402	80186	5310-01-105-7122	12	28
32897	814150651225M50V	- - -	8	32
06540	8217-S0632-3B	1680-01-151-9214	6	74
06540	8217-S0632-3B	1680-01-151-9214	6	88
96906	8217-S0632-3B	1680-01-151-9214	6	71
83330	8505	5365-00-455-6940	6	72
82402	8732	5977-01-073-7394	12	26
82402	886-1	- . .	10	30
82402	886-108	5365-01-071-3643	13	5
82402	886-109	5365-01-071-3644	13	6
82402	886-11	5365-01-072-9731	12	36
82402	886-12	5365-01-454-8684	10	23
82402	886-121	5365-01-072-9733	12	18
82402	886-13	5365-01-071-3641	13	24
82402	886-144	5365-01-081-5692	10	24
82402	886-167	5365-01-065-7320	19	7
82402	886-168	5365-01-065-7321	19	8
82402	886-169	5365-01-065-7322	19	9
82402	886-2	5365-01-071-3645	13	22
82402	886-211	5365-00-119-9352	10	32
82402	886-229	5365-01-073-5452	12	53
82402	886-231	5365-01-072-2932	12	54
82402	886-249	5365-01-071-4975	19	34
82402	886-250	5365-01-071-4972	19	35
82402	886-251	5365-01-071-3973	19	36
82402	886-29	5365-00-161-4109	10	31
82402	886-360	5365-01-105-7134	20	12
82402	886-361	5365-01-105-7133	20	13
82402	886-362	5365-01-105-7132	20	14
82402	886-4	5365-01-071-3646	13	18
82402	886-5	5365-01-836-2808	10	22
82402	886-53	5365-01-071-3642	13	4
82402	886-7	5365-01-060-3788	10	17
82402	886-7	5365-01-060-3788	12	35
82402	886-94	5365-00-454-8687	12	52
82402	886-97	5365-00-072-9729	12	17
21335	9105KPP	3110-00-109-1183	18	99
82402	9164	5365-01-073-3030	7	2
91340	D14131-6	5330-00-298-0540	19	11
21335	9306K	3110-00-516-5377	18	141

APPENDIX D

EXPENDABLE SUPPLIES AND MATERIALS LIST

Section L INTRODUCTION

D-1. Scope. This appendix lists expendable supplies and materials you will need to operate and maintain the rescue hoist. These items are authorized to you by CTA 50-970, Expendable Items (Except Medical, Class V, Repair Parts, and Heraldic Items).

D-2. Explanation of Columns.

a. ITEM NUMBER (Column 1). This number is assigned to the entry in the listing and is referenced in the maintenance tasks to identify the material (e.g., Cleaning Compound (Item 5, App. D)).

b. LEVEL (Column 2), This column identifies the lowest level of maintenance that requires the listed item,

- c - Operator J Crew
- O - Organizational Maintenance
- F - Direct Support Maintenance
- H - General Support Maintenance

c. NATIONAL STOCK NUMBER (Column 3). This is the National Stock Number assigned to the item; use it to request or requisition the item.

d. DESCRIPTION (Column 4). Indicates the item name and, if required, a description to identify the item. The last line for each item indicates the part number followed by the Federal Supply Code for Manufacturer (FSCM) in parentheses.

e. UNIT OF MEASURE (U/M) (Column 5). Indicates the measure used in performing the actual maintenance function. This measure is expressed by a two-character alphabetical abbreviation (e.g., ea, in, pr. If the unit of measure differs from the unit of issue, requisition the lowest unit of issue that will satisfy your requirements.

Section II

EXPENDABLE SUPPLIES AND MATERIALS LIST

(1) ITEM NO.	(2) LEVEL	(3) NATIONAL STOCK NUMBER	(4) DESCRIPTION	(5) U/M
1	AVUM/AVIM	5350-00-192-5051	Abrasive Cloth, Aluminum Oxide, P-C451	ea
2	AVUM/AVIM	8040-00-851-0211	Adhesive, RTV-732, Clear	oz
3	AVUM/AVIM	9150-00-698-2382	Automatic Transmission Fluid, Dexron Type 2, MIL-L-46167	qt
4	AVIM	8040-00-865-8991	Adhesive, RTV103	oz
5	AVUM/AVIM	5306-00-282-5821	Bolt, AN3H26A	ea
6	AVUM		Cap Plug, EP32, NAS820-32-32S	ea
7	AVUM		Cap Plug, EP14, NAS820-14-14S	ea
8	AVUM		Cap Plug, EP12, NAS820-12-12S	ea
9	AVUM		Cap Plug, EP16, NAS820-16-16S	ea
10	AVUM/AVIM	6850-00-285-8011	Cleaning Solvent, P-D-680, Type II	dr
11	AVIM	6145-00-728-4026	Electric Braid, QQB575	AR
12	AVIM	9150-00-944-8953	Grease, WTR, MIL, G-81322	qt
13	AVUM/AVIM	9150-00-252-6382	Hydraulic Fluid, MIL-H-S606	qt
14	AVUM/AVIM	5790-00-954-1624	Insulation Sleeving, FIT2213-8 Black	AR
15			Lacquer, Acrylic, MIL-L-81352, Color 37038	
16	AVUM/AVIM	8030-00-964-7537	Loctite Compound, Grade C, Item No. 8431, MIL-S-24473E	oz
17	AVUM/AVIM	9525-00-618-0257	Lockwire, MS20995C20	lb
18	AVUM/AVIM	9505-00-355-6072	Lockwire, MS20995C32	lb
19	AVUM/AVIM	9150-00-250-0926	Petrolatum, VV-P-236	cn.
20		8010-00-935-7080	Primer, Polyimide Epoxy, MIL-P-23377, Type I	kt

EXPENDABLE SUPPLIES AND MATERIALS LIST (cont)

(1) ITEM NO.	(2) LEVEL	(3) NATIONAL STOCK NUMBER	(4) DESCRIPTION	(5) U/M
21		8010-00-899-0931	Primer, Zinc Chromate, IT-P- I 757	QT
22		8030-01-131-9189	Sealing Compound, MIL-S-46163, Type I, Grade K	oz
23		3439-00-404-8023	Solder, Resin, QQ-S-571, SN60	LB
24		3439-00411-5097	Solder, Resin, QQ-S-571, SN96	LB
25	AVUM/AVIM	6810-00-476-5612	Trichloroethane, 1,1,1-, MIL-T-81533	cn
26	AVIM	5970-00-954-1624	Tubing, Heat Shrink, MIL-I-23053/5	AR
27			Varnish, BC305, John Dolph Co.	

APPENDIX E

TORQUE LIMITS

TORQUE VALUES FOR STANDARD BOLTS, SCREWS, AND NUTS

<u>Thread Size</u>	<u>Torque Value</u>
3-48	5-7 in. lbs. (0.6-0.8 N.m)
6-32	11-13 in. lbs. (1.2-1.5 N.m)
8-32	13-16 in. lbs. (1.5-1.8 N.m)
10-32	24-27 in. lbs. (2.7-3.0 N.m)
1/4-28	55-70 in. lbs. (6.27-9 N.m)

MINIMUM DRAG TORQUE FOR SELF-LOCKING NUTS

<u>Thread Size</u>	<u>Torque Value</u>
10-32	2.0 in. lb. (0.2 N.m)
1/4-28	3.5 in. lbs. (0.4 N.m)
3/8-24	9.5 in. lbs. (1.07 N.m)

Torque Wrench, 0-30 inch-pounds

NSN 5120-00-1174832

Torque Wrench, 30-150 inch-pounds

NSN 5120-00-542-4489

APPENDIX F

TEST EQUIPMENT LIST

EQUIPMENT NOMENCLATURE	PART NUMBER
Magnetic Particle Inspection Equipment	Coml
Fluorescent Pemrant Inspedon Equipment	Coml
Radiographic Inspection Equipment	Coml

GLOSSARY

Section 1. ABBREVIATIONS

App.	Appendix
AR	As Required
AVIM	Aviation Intermediate Maintenance
ALUM	Aviation Unit Maintenance
bg	bag
cm	centimeter
DA	Department of the Army
dm	decimeter
ea	each
m.	Equipment Improvement Recommendation
FM	Field Manual
FAD	Foreign Object Damage
ft	foot
gal	gallon
GNU	Ground Power Unit
in	inch
kg	kilogram
l	liter
lb	pound
MAC	Maintenance Allocation Chart
max	maximum
min	minimum
oz	ounce
PMCS	Preventive Maintenance Checks and Services
psi	pounds per square inch
pig	pounds per square inch gage
pt	pint
QDR	Quality Deficiency Report
qt	quart
RAM	Reliability Centered Maintenance
REF	reference
Al	roll
rpm	revolutions per minute
RPSTL	Repair Parts and Special Tools List
TAB	Technical Bulletin
TM	Technical Manual
TMDE	Test, Measurement, and Diagnostic Equipment
U/M	Unit of Measure
ye	yard

GLOSSARY

Section 2. DEFINITIONS

TERM	Definition
B	
Bend	Distortion in a part.
Binding	To confine and restrict the liberty of a free moving part, material or component. May cause serious damage if a chafing force is being imposed.
Break	Separation of a part.
Burnishing	Smoothing minor damage using a hand tool.
Burr	A rough or sharp edge on a hole or corner, usually caused by machining, sometimes by wearing.
C	
chipping	Breaking away of metallic particles.
Contamination (Foreign Material)	Any foreign substance such as metal chips, lint, rust and water that would be harmful to the functioning of a part or system.
Corrosion (Direct Surface Attack)	A type of corrosion that results from direct reaction between a metal surface and the atmosphere. Rust on iron is a common example.
Corrosion (Galvanic)	Accelerated corrosion as a result of electrical contact between dissimilar metals.
Corrosion (Intergranular)	A corrosion type which attacks along the grain boundaries of a metal.
Corrosion (Pitting)	Formation of small cavities on a metallic surface caused by chemical or physical nonhomogeneities.
Corrosion (Stress Cracking)	A type of corrosion which causes cracking and part failure due to a combination of corrosion and sustained tensile stress.
Crack	Parting of parent metal.

GLOSSARY

Section 2. DEFINITIONS (Cont)

TERM	DEFINITION
D	
Dent	A completely smooth surface depression caused by pressure or impact from a smooth ball-like foreign object. The parent material is displaced, but usually none is separated.
Distortion	Twisting or bending out of a normal, natural or original shape, usually caused from being exposed to excessive pressure or temperature either when restrained or unrestrained.
E	
Errosion	Wearing away of metal.
F	
Ferrules	Metal band or socket.
Foreign Material	See Contamination,
Foreign Object	Any object such as a tool, piece of equipmen, APU part (nut, bolt, lockwire) that could in any way damage the unit.
Fraying	Wearing or rubbing of areas, generally used in reference to damage on wire-braid covering (of teflon hose) or on thermocouple harness.
G	
Gouge	A wide rough scratch or group of scratches, usually, with one or more sharply impressed corners, and frequently accompanied by deformation or removal of parent metal,
K	
Kinks	Short, tight twists or curls caused by a doubling or winding of a hose or line upon itself. Likely to cause difficulties in the operation.

GLOSSARY

section 2. **DEFINITIONS (Cent)**

TERM	DEFINITION
L	
Loose	Abnormal movement of a part.
N	
Nick	A surface impression with sharp comers or bottom, usually caused by pressure or impact from a sharp-edged foreign body. Th e parent material is displaced but usually none is separated.
P	
Parent Metal	The basic metal of a part, sometimes referred to as base metal; the term is used particularly in connection with welding, where the parent metal is that being welded rather than that used in welding rod.
Puncture	A hole that is pierced in a material.
R	
Repair	To restore a defective part, component, subassembly or assembly to a serviceable condition.
Rub	When one component contacts another and is moved in relationship to it causing material to be removed from it.
s	
scoring	Multiple scratches, usually parallel and resulting from the same cause.
scratch	A long, narrow sharp-cornered impression caused by the movement of a sharp object across the surface of parent material.
Serviceable	Equipment or parts that are in a condition which allows them to be returned to operational status on an air-craft.

GLOSSARY

Section 2. DEFINITIONS (Cont)

TERM	DEFINITION
Testing	Testing of equipment to determine that the unit functions properly within specified limits.
Tolerance	The range of variation allowed in maintaining a specified dimension in making part.
Torque	To tighten a nut, bolt or fitting, using a torque wrench, to a specified torque value expressed as inch-pounds or as foot-pounds.
w	
Wear	Relatively slow removed of parent material from any cause, frequently not visible to the naked eye.

ALPHABETICAL INDEX

Subject/Para.	Subject/Para.
A	
Actuator Assembly (Up Limit)	Brake Assembly (Automatic)
Adjust, 2-66	Adjust, 3-141
Inspect, 2-65	Inspect, 3-140
Replace, 2-68	Repair, 3-144
Adjust	Replace, 3-150
Actuator Assembly (Up Limit), 2-66	Brake Assembly (Boom Head)
Automatic Brake Assembly, 3-141	Adjust, 3-71
Boom Head Assembly, 3-52	Inspect, 3-67
Boom Position Support Assembly, 2-73	Repair, 3-68
Brake Assembly (Automatic), 3-141	Replace, 3-73
Brake Assembly (Boom Head), 3-71	
Clutch Assembly, 3-79	c
Hoist, 3-40	Cable Assembly
Limit Switch Drive Assembly, 2-114	Inspect, 2-127
Rescue Hoist, 3-40	Replace, 2-128
Winch Assembly, 2-98	Cable Cutter Assembly
Align	Inspect, 2-62
Drum Assembly, 2-137	Replace, 2-63
Winch Assembly, 2-99	Cable Hook Assembly
Automatic Brake Assembly	Inspect, 2-120
Adjust, 3-141	Repair, 2-122
Inspect, 3-140	Replace, 2-125
Repair, 3-144	Cables and Connectors, Electrical
Replace, 3-150	Inspect, 2-140
	Repair, AVIM, 3-152
B	Repair, AVUM, 2-141
Blower Assembly / DC Motor	Replace, AVIM, 3-153
Replace, 3-93	Replace, AVUM, 2-142
Boom Head Assembly	Calibration, 1-1
Adjust, 3-52	Characteristics, Capabilities and Features, 1-2
Inspect, 2-48	Control Panel Assembly
Principles of Operation, 1-9	Principles of Operation, 1-11
Repair, AVIM, 3-53	Repair, 3-92
Repair, AVUM, 2-51	Replace, 2-70
Replace, 2-58	Control Pendant Assembly
Service, 2-49	Inspect, 2-45
Boom Position Support Assembly	Principles of Operation, 1-11
Adjust, 2-73	Repair, 3-40
Inspect, 2-72	Replace, 2-46
Principles of Operation, 1-10	Clutch Assembly
Repair, AVIM, 3-95	Adjust, 3-79
Repair, AVUM, 2-77	Inspect, 3-75
Replace, 3-103	Repair, 3-76
	Replace, 3-81

D

Destruction of Army Material, 1-1
Drum Assembly
 Align, 2-137
 Inspect, 2-136

E

EIR, 1-1
Electric Motor
 Inspect, 2-107
 Replace, 2-108
Electrical Cables and Connectors
 Inspect, 2-140
 Repair, 2-141
 Replace, 2-142
Equipment Characteristics, Capabilities and Features, 1-2
Equipment Data, 1-7
Equipment Description and Data, 1-2
Equipment Improvement Recommendations (EIR), Reporting, 1-1
Expendable Supplies and Materials List, D-1

F

Flexible Shaft Assembly
 Inspect, 3-89
 Replace, 3-90
Flexible Wiring Harness
 Inspect, 3-108
 Replace, 3-111

G

General Information - Rescue Hoist, 1-1

H

Height Adjuster Assembly
 Inspect, 2-80
 Repair, 2-81
 Replace, 2-84
Hoist, Rescue
 Adjust, 3-40

Characteristics, Capabilities and Features, 1-2
Equipment Characteristics, Capabilities and Features, 1-2
Equipment Data, 1-7
Equipment Description and Data, 1-2
General Information 1-1
Inspect, 2-39
Installation Instructions, AVIM, 3-2
Installation Instructions, AVUM, 2-2
Introduction, 1-1
Location and Description of Major Components, 1-2
Major Components, Location and Description of, 1-2
Operational Performance Check, AVIM, 3-8
Operational Performance Check, AVUM, 2-8
Performance Check, Operational, AVIM, 3-8
Performance Check, Operational, AVUM, 2-8
Preliminary Servicing of Equipment, AVIM, 3-6
Preliminary Servicing of Equipment, AVUM, 2-6
Preparation for Storage or Shipment, AVUM, 2-143
Preparation for Storage or Shipment, AVIM, 3-154
Principles of Operation, 1-7
Repair, AVIM, 3-43
Repair, AVUM, 2-44
Service, 2-43
Service Upon Receipt, AVIM, 3-2
Service Upon Receipt, AVUM, 2-2
Servicing of Equipment, Preliminary, AVIM, 3-6
Servicing of Equipment, Preliminary, AVUM, 2-6
Technical Principles of Operation, 1-7
Test, 2-42
Troubleshooting, AVIM, 3-20
Troubleshooting, AVUM, 2-20
Hoist Cable Assembly
 Inspect, 2-127
 Replace, 2-128
Hook Assembly, Cable
 Inspect, 2-120
 Repair, 2-122
 Replace, 2-125

I

Inertia Dump Assembly

- Inspect, 2-110
- Replace, 2-111

Inspect

- Actuator Assembly (Up Limit), 2-65
- Automatic Brake Assembly, 3-140
- Boom Head Assembly, 2-48
- Boom Position Support Assembly, 2-72
- Brake Assembly (Automatic), 3-140
- Brake Assembly (Boom Head), 3-67
- Cable Hook Assembly, 2-120
- Cables and Connectors, Electrical, 2-140
- Clutch Assembly, 3-75
- Control Pendant Assembly, 2-45
- Drum Assembly, 2-136
- Electric Motor, 2-107
- Electrical Cables and Connectors, 2-140
- Flexible Shaft Assembly, 3-89
- Flexible Wiring Harness, 3-108
- Height Adjuster Assembly, 2-80
- Hoist, 2-39
- Hoist Cable Assembly, 2-127
- Hook Assembly, 2-120
- Inertia Dump Assembly, 2-110
- Limit Switch Drive Assembly, 2-113
- Lower Support Assembly, 2-89
- Level Wind Shoe, 2-132
- Quick Disconnect (Reaction Arm), 2-93
- Quick Disconnect (Upper Support), 2-85
- Reaction Ann Assembly, 2-91
- Rescue Hoist, 2-39
- Support Assembly, Upper, 2-87
- Support Assembly, Lower, 2-89
- Upper Support Assembly, 2-87
- Winch Assembly, 2-95

Installation Instructions, AVIM, 3-2

Installation Instructions, AVUM, 2-2

Introduction - Rescue Hoist, 1-1

L

Level Wind Shoe

- Inspect, 2-127
- Replace, 2-128

Limit Switch Drive Assembly

- Adjust, 2-114

Inspect, 2-113

Repair, 3-129

Replace, 2-118

Test, 3-138

Location and Description of Major Components, 1-2

Lower Support Assembly

- Inspect, 2-89
- Repair, AVIM, 3-106
- Repair, AVUM, 2-90
- Replace, 3-107

M

MAC, B-1

Maintenance Allocation Chart (MAC), B-1

Maintenance Checks and Services, Preventive, (PMCS), AVIM, 3-14

Maintenance Checks and Services, Preventive, (PMCS), AWM, 2-14

Maintenance Forms, Records and Reports, 1-1

Maintenance Procedures, AVIM, 3-40

Maintenance Procedures, AVUM, 2-39

Major Components, Location and Description of, 1-2

Microswitch Assembly (Full Up)

Replace, 3-83

Test. 2-69

O

Operation, Principles of, 1-7

Operational Performance Check, AVIM, 3-8

Operational Performance Check, AVUM, 2-8

P

Performance Check, Operational, AVIM, 3-8

Performance Check, Operational, AVUM, 2-8

Preliminary Servicing of Equipment, AVUM, 2-6

Preparation for Storage or Shipment, AVUM, 2-143

Principles of Operation, 1-7

PMCS, AVIM, 3-14

PMCS, AVUM, 2-14

Preventive Maintenance Checks and Services (PMCS), AVIM, 3-14

Preventive Maintenance Checks and Services (PMCS), AVUM. 2-14

Q

Quick Disconnect (Reaction Arm)

Inspect, 2-93

Replace, 2-94

Quick Disconnect (Upper Support)

Inspect, 2-85

Replace, 2-86

R

Reaction Arm Assembly

Inspect, 2-91

Replace, 2-92

Reference Materials, A-1

Repair

Automatic Brake Assembly, 3-144

Boom Head Assembly, 2-51

Boom Position Support Assembly, 2-77

Brake Assembly (Automatic), 3-144

Cable Hook Assembly, 2-122

Cables and Connectors, Electrical, AVIM, 3-152

Cables and Connectors, Electrical, AVUM, 2-141

Electrical Cables and Connectors, AVIM, 3-152

Electrical Cables and Connectors, AVUM, 2-141

Height Adjuster Assembly, 2-81

Hoist, 2-44

Hook Assembly, 2-122

Limit Switch Drive Assembly, 3-129

Lower Support Assembly, AVIM, 3-106

Lower Support Assembly, AVUM, 2-90

Rescue Hoist, AVIM, 3-43

Rescue Hoist, AVUM, 2-44

Support Assembly, Lower, AVIM, 3-106

Support Assembly, Lower, AVUM, 2-90

Support Assembly, Upper, 2-88

Upper Support Assembly, 2-88

Winch Assembly, AVIM, 3-116

Winch Assembly, AVUM, 2-100

Repair Parts and Special Tools List, AVIM, 3-1

Repair Parts and Special Tools List, AVUM, 2-1

Replace

Actuator Assembly (Up Limit), 2-68

Automatic Brake Assembly, 3-150

Blower Assembly / DC Motor, 3-93

Boom Head Assembly, 2-58

Boom Position Support Assembly, 3-103

Brake Assembly (Automatic), 3-150

Brake Assembly (Boom Head), 3-73

Cable Assembly, 2-128

Cable Cutter Assembly, 2-63

Cable Hook Assembly, 2-125

Cables and Connectors, Electrical, AVIM, 3-153

Cables and Connectors, Electrical, AWM, 2-142

Clutch Assembly, 3-81

Control Panel Assembly, 2-70

Control Pendant Assembly, 2-46

Electrical Cables and Connectors, AVIM, 3-153

Electrical Cables and Connectors, AVUM, 2-142

Flexible Shaft Assembly, 3-90

Flexible Wiring Harness, 3-111

Height Adjuster Assembly, 2-84

Hoist Cable Assembly, 2-128

Hook Assembly, 2-125

Level Wind Shoe, 2-133

Limit Switch Drive Assembly, 2-118

Microswitch Assembly (Full Up), 3-83

Quick Disconnect (Reaction Arm), 2-94

Quick Disconnect (Upper Support), 2-86

Reaction Arm Assembly, 2-92

Support Assembly, Lower, 3-107

Support Assembly, Upper, 3-104

Upper Support Assembly, 3-104

Winch Assembly, 3-127

Reporting Equipment Improvement Recommendations (EIR), 1-1

Rescue Hoist

Adjust, 3-40

Characteristics, Capabilities and Features, 1-2

Equipment Characteristics, Capabilities and Features, 1-2

Equipment Data, 1-7

Equipment Description and Data, 1-2

General Information, 1-1

Inspect, 2-39

Installation Instructions, AVIM, 3-2

Installation Instructions, AVUM, 2-2

Introduction, 1-1

Location and Description of Major

Components, 1-2

Major Components, Location and Description of, 1-2

Operational Performance Check, AVIM, 3-8

Operational Performance Check, AVUM, 2-8

Performance Check, Operational, AVIM, 3-8

Performance Check, Operational, AWM, 2-8

Preliminary Servicing of Equipment, AVIM, 3-6

Preliminary Servicing of Equipment, AVUM, 2-6

- Preparation for Storage or Shipment, AVUM, 2-145
- Preparation for Storage or Shipment, AVIM, 3-152
- Principles of Operation, 1-7
- Repair, AVIM, 3-43
- Repair, AVUM, 2-44
- Sewice, 2-43
- Sewice Upon Receipt, AVIM, 3-2
- Service Upon Receipt, AVUM, 2-2
- Servicing of Equipment, Preliminary, AVIM, 3-6
- Servicing of Equipment, Preliminary, AVUM, 2-6
- Technical Principles of Operation, 1-7
- Test, 2-42
- Troubleshooting, AVIM, 3-20
- Troubleshooting, AVUM, 2-20
- Rescue Hoist Assembly, Principles of Operation, 1-7
- Repair Parts and Special Tools List, C-1
- RPSTL,C-1
- RPSTL, AVIM, 3-1
- RPSTL, AVUM, 2-1

S

- Service
 - Boom Head Assembly, 2-49
 - Hoist, 2-43
 - Rescue Hoist, 2-43
 - Winch Assembly, 2-96
- Sewice Upon Receipt, AVIM, 3-2
- Service Upon Receipt, AVUM, 2-2
- Servicing of Equipment, Preliminary, AVIM, 3-6
- Servicing of Equipment, Preliminary, AVUM, 2-6
- Special Tools, C-1
- Special Tools List, Repair Parts and, AVIM, 3-1
- Special Tools List, Repair Parts and, AVUM, 2-1
- Support Assembly, Lower
 - Inspect, 2-89
 - Repair, AVIM, 3-106
 - Repair, AVUM, 2-90
 - Replace, 3-107
- Support Assembly, Upper
 - Inspect, 2-87
 - Repair, 2-88
 - Replace, 3-104

- Support Equipment, AVIM, 3-1
- Support Equipment, AVUM, 2-1

T

- Technical Principles of Operation, 1-7
- Test
 - Hoist, 2-42
 - Limit Switch Drive Assembly, 3-138
 - Microswitch Assembly (Full Up), 2-69
 - Rescue Hoist, 2-42
- Test Equipment List, G-1
- Test, Measurement, and Diagnostic Equipment, AVIM, 3-1
- Test, Measurement, and Diagnostic Equipment, AVUM, 2-1
- TMDE, AVIM, 3-1
- TMDE, AVUM, 2-1
- Tools, Special, C-1
- Torque Limits, E-1
- Troubleshooting, AVIM, 3-20
- Troubleshooting, AVUM, 2-20

U

- Upper Support Assembly
 - Inspect, 2-87
 - Repair, 2-88
 - Replace, 3-104

W

- Winch Assembly
 - Adjust, 2-98
 - Align, 2-99
 - Inspect, 2-95
 - Principles of Operation, 1-7
 - Repair, AVIM, 3-116
 - Repair, AVUM 2-100
 - Replace, 3-127
 - Service, 2-96

By Order of the Secretary of the Army:

Official:

CARL E. VUONO
General, *United States Army*
Chief of Staff

WILLIAM J. MEEHAN II
Brigadier General, United States Army
The Adjutant General

DISTRIBUTION:

To be distributed in accordance with DA Form 12-31, AVUM and AVIM Maintenance requirements for AH-64A Helicopter, Attack (APACHE).

These are the instructions for sending an electronic 2028

The following format must be used if submitting an electronic 2028. The subject line must be exactly the same and all fields must be included; however only the following fields are mandatory: 1, 3, 4, 5, 6, 7, 8, 9, 10, 13, 15, 16, 17, and 27.

From: "Whomever" <whomever@wherever.army.mil>

To: 2028@redstone.army.mil

Subject: DA Form 2028

1. **From:** Joe Smith
2. **Unit:** home
3. **Address:** 4300 Park
4. **City:** Hometown
5. **St:** MO
6. **Zip:** 77777
7. **Date Sent:** 19-OCT-93
8. **Pub no:** 55-2840-229-23
9. **Pub Title:** TM
10. **Publication Date:** 04-JUL-85
11. **Change Number:** 7
12. **Submitter Rank:** MSG
13. **Submitter FName:** Joe
14. **Submitter MName:** T
15. **Submitter LName:** Smith
16. **Submitter Phone:** 123-123-1234
17. **Problem:** 1
18. **Page:** 2
19. **Paragraph:** 3
20. **Line:** 4
21. **NSN:** 5
22. **Reference:** 6
23. **Figure:** 7
24. **Table:** 8
25. **Item:** 9
26. **Total:** 123
27. **Text:**

This is the text for the problem below line 27.

RECOMMENDED CHANGES TO PUBLICATIONS AND BLANK FORMS <small>For use of this form, see AR 25-30; the proponent agency is ODISC4.</small>	Use Part II (reverse) for Repair Parts and Special Tool Lists (RPSTL) and Supply Catalogs/Supply Manuals (SC/SM)	DATE <h2 style="text-align: center;">8/30/02</h2>
--	--	--

TO: (Forward to proponent of publication or form)(Include ZIP Code) Commander, U.S. Army Aviation and Missile Command ATTN: AMSAM-MMC-MA-NP Redstone Arsenal, 35898	FROM: (Activity and location)(Include ZIP Code) MSG, Jane Q. Doe 1234 Any Street Nowhere Town, AL 34565
--	--

PART 1 - ALL PUBLICATIONS (EXCEPT RPSTL AND SC/SM) AND BLANK FORMS

PUBLICATION/FORM NUMBER <h3 style="text-align: center;">TM 9-1005-433-24</h3>	DATE <h3 style="text-align: center;">16 Sep 2002</h3>	TITLE Organizational, Direct Support, And General Support Maintenance Manual for Machine Gun, .50 Caliber M3P and M3P Machine Gun Electrical Test Set Used On Avenger Air Defense Weapon System
--	--	---

ITEM NO.	PAGE NO.	PARA-GRAPH	LINE NO. *	FIGURE NO.	TABLE NO.	RECOMMENDED CHANGES AND REASON
1	WP0005 PG 3		2			Test or Corrective Action column should identify a different WP number. <div style="position: absolute; top: 50%; left: 50%; transform: translate(-50%, -50%) rotate(-45deg); font-size: 100px; opacity: 0.5; pointer-events: none;"> EXAMPLE </div>

* Reference to line numbers within the paragraph or subparagraph.

TYPED NAME, GRADE OR TITLE <h3 style="text-align: center;">MSG, Jane Q. Doe, SFC</h3>	TELEPHONE EXCHANGE/ AUTOVON, PLUS EXTENSION <h3 style="text-align: center;">788-1234</h3>	SIGNATURE
--	---	-----------

TO: (Forward direct to addressee listed in publication) Commander, U.S. Army Aviation and Missile Command ATTN: AMSAM-MMC-MA-NP Redstone Arsenal, 35898	FROM: (Activity and location) (Include ZIP Code) MSG, Jane Q. Doe 1234 Any Street Nowhere Town, AL 34565	DATE 8/30/02
---	--	------------------------

PART II - REPAIR PARTS AND SPECIAL TOOL LISTS AND SUPPLY CATALOGS/SUPPLY MANUALS

PUBLICATION NUMBER			DATE	TITLE				
PAGE NO.	COLM NO.	LINE NO.	NATIONAL STOCK NUMBER	REFERENCE NO.	FIGURE NO.	ITEM NO.	TOTAL NO. OF MAJOR ITEMS SUPPORTED	RECOMMENDED ACTION

PART III - REMARKS (Any general remarks, space limitations, or suggestions for improvement of publications and blank forms. Additional blank sheets may be used if more space is needed.)

EXAMPLE

TYPED NAME, GRADE OR TITLE MSG, Jane Q. Doe, SFC	TELEPHONE EXCHANGE/AUTOVON, PLUS EXTENSION 788-1234	SIGNATURE
---	--	-----------

RECOMMENDED CHANGES TO PUBLICATIONS AND BLANK FORMS For use of this form, see AR 25-30; the proponent agency is ODISC4.	Use Part II (reverse) for Repair Parts and Special Tool Lists (RPSTL) and Supply Catalogs/Supply Manuals (SC/SM)	DATE
---	--	------

TO: (Forward to proponent of publication or form)(Include ZIP Code) Commander, U.S. Army Aviation and Missile Command ATTN: AMSAM-MMC-MA-NP Redstone Arsenal, AL 35898	FROM: (Activity and location)(Include ZIP Code)
---	---

PART 1 - ALL PUBLICATIONS (EXCEPT RPSTL AND SC/SM) AND BLANK FORMS

PUBLICATION/FORM NUMBER TM 55-1680-320-23&P	DATE 15 DECEMBER 2003	TITLE Aviation Unit and Intermediate Maintenance High Performance Recue Hoist Assy
---	---------------------------------	--

ITEM NO.	PAGE NO.	PARA-GRAPH	LINE NO. *	FIGURE NO.	TABLE NO.	RECOMMENDED CHANGES AND REASON

* Reference to line numbers within the paragraph or subparagraph.

TYPED NAME, GRADE OR TITLE	TELEPHONE EXCHANGE/ AUTOVON, PLUS EXTENSION	SIGNATURE
----------------------------	--	-----------

TO: (Forward direct to addressee listed in publication) Commander, U.S. Army Aviation and Missile Command ATTN: AMSAM-MMC-MA-NP Redstone Arsenal, AL 35898	FROM: (Activity and location) (Include ZIP Code)	DATE
--	---	-------------

PART II - REPAIR PARTS AND SPECIAL TOOL LISTS AND SUPPLY CATALOGS/SUPPLY MANUALS

PUBLICATION NUMBER TM 55-1680-320-23&P	DATE 15 DECEMBER 2003	TITLE Aviation Unit and Intermediate Maintenance High Performance Recue Hoist Assy
--	------------------------------------	---

PAGE NO.	COLM NO.	LINE NO.	NATIONAL STOCK NUMBER	REFERENCE NO.	FIGURE NO.	ITEM NO.	TOTAL NO. OF MAJOR ITEMS SUPPORTED	RECOMMENDED ACTION

PART III - REMARKS (Any general remarks or recommendations, or suggestions for improvement of publications and blank forms. Additional blank sheets may be used if more space is needed.)

TYPED NAME, GRADE OR TITLE	TELEPHONE EXCHANGE/AUTOVON, PLUS EXTENSION	SIGNATURE
----------------------------	--	-----------

RECOMMENDED CHANGES TO PUBLICATIONS AND BLANK FORMS For use of this form, see AR 25-30; the proponent agency is ODISC4.	Use Part II (reverse) for Repair Parts and Special Tool Lists (RPSTL) and Supply Catalogs/Supply Manuals (SC/SM)	DATE
---	--	------

TO: (Forward to proponent of publication or form)(Include ZIP Code) Commander, U.S. Army Aviation and Missile Command ATTN: AMSAM-MMC-MA-NP Redstone Arsenal, AL 35898	FROM: (Activity and location)(Include ZIP Code)
---	---

PART 1 - ALL PUBLICATIONS (EXCEPT RPSTL AND SC/SM) AND BLANK FORMS

PUBLICATION/FORM NUMBER TM 55-1680-320-23&P	DATE 15 DECEMBER 2003	TITLE Aviation Unit and Intermediate Maintenance High Performance Recue Hoist Assy
---	---------------------------------	--

ITEM NO.	PAGE NO.	PARA-GRAPH	LINE NO. *	FIGURE NO.	TABLE NO.	RECOMMENDED CHANGES AND REASON

* Reference to line numbers within the paragraph or subparagraph.

TYPED NAME, GRADE OR TITLE	TELEPHONE EXCHANGE/ AUTOVON, PLUS EXTENSION	SIGNATURE
----------------------------	--	-----------

TO: (Forward direct to addressee listed in publication) Commander, U.S. Army Aviation and Missile Command ATTN: AMSAM-MMC-MA-NP Redstone Arsenal, AL 35898	FROM: (Activity and location) (Include ZIP Code)	DATE
--	---	-------------

PART II - REPAIR PARTS AND SPECIAL TOOL LISTS AND SUPPLY CATALOGS/SUPPLY MANUALS

PUBLICATION NUMBER TM 55-1680-320-23&P	DATE 15 DECEMBER 2003	TITLE Aviation Unit and Intermediate Maintenance High Performance Recue Hoist Assy
--	------------------------------------	---

PAGE NO.	COLM NO.	LINE NO.	NATIONAL STOCK NUMBER	REFERENCE NO.	FIGURE NO.	ITEM NO.	TOTAL NO. OF MAJOR ITEMS SUPPORTED	RECOMMENDED ACTION

PART III - REMARKS (Any general remarks or recommendations, or suggestions for improvement of publications and blank forms. Additional blank sheets may be used if more space is needed.)

TYPED NAME, GRADE OR TITLE	TELEPHONE EXCHANGE/AUTOVON, PLUS EXTENSION	SIGNATURE
----------------------------	--	-----------

RECOMMENDED CHANGES TO PUBLICATIONS AND BLANK FORMS For use of this form, see AR 25-30; the proponent agency is ODISC4.	Use Part II (reverse) for Repair Parts and Special Tool Lists (RPSTL) and Supply Catalogs/Supply Manuals (SC/SM)	DATE
---	--	------

TO: (Forward to proponent of publication or form)(Include ZIP Code) Commander, U.S. Army Aviation and Missile Command ATTN: AMSAM-MMC-MA-NP Redstone Arsenal, AL 35898	FROM: (Activity and location)(Include ZIP Code)
---	---

PART 1 - ALL PUBLICATIONS (EXCEPT RPSTL AND SC/SM) AND BLANK FORMS

PUBLICATION/FORM NUMBER TM 55-1680-320-23&P	DATE 15 DECEMBER 2003	TITLE Aviation Unit and Intermediate Maintenance High Performance Recue Hoist Assy
---	---------------------------------	--

ITEM NO.	PAGE NO.	PARA-GRAPH	LINE NO. *	FIGURE NO.	TABLE NO.	RECOMMENDED CHANGES AND REASON

* Reference to line numbers within the paragraph or subparagraph.

TYPED NAME, GRADE OR TITLE	TELEPHONE EXCHANGE/ AUTOVON, PLUS EXTENSION	SIGNATURE
----------------------------	--	-----------

TO: (Forward direct to addressee listed in publication) Commander, U.S. Army Aviation and Missile Command ATTN: AMSAM-MMC-MA-NP Redstone Arsenal, AL 35898	FROM: (Activity and location) (Include ZIP Code)	DATE
--	---	-------------

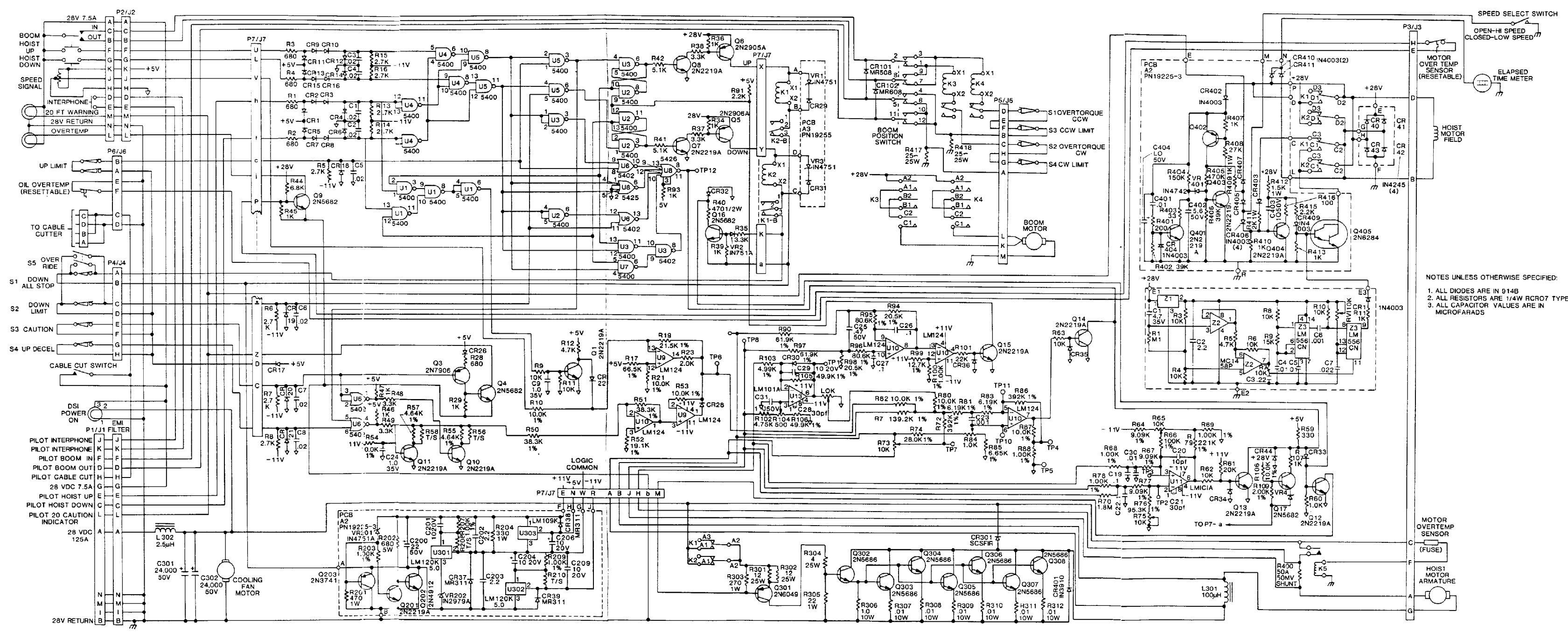
PART II - REPAIR PARTS AND SPECIAL TOOL LISTS AND SUPPLY CATALOGS/SUPPLY MANUALS

PUBLICATION NUMBER TM 55-1680-320-23&P	DATE 15 DECEMBER 2003	TITLE Aviation Unit and Intermediate Maintenance High Performance Recue Hoist Assy
--	------------------------------------	---

PAGE NO.	COLM NO.	LINE NO.	NATIONAL STOCK NUMBER	REFERENCE NO.	FIGURE NO.	ITEM NO.	TOTAL NO. OF MAJOR ITEMS SUPPORTED	RECOMMENDED ACTION

PART III - REMARKS (Any general remarks or recommendations, or suggestions for improvement of publications and blank forms. Additional blank sheets may be used if more space is needed.)

TYPED NAME, GRADE OR TITLE	TELEPHONE EXCHANGE/AUTOVON, PLUS EXTENSION	SIGNATURE
----------------------------	--	-----------



- NOTES UNLESS OTHERWISE SPECIFIED:
1. ALL DIODES ARE IN 914B
 2. ALL RESISTORS ARE 1/4W RCRO7 TYPE
 3. ALL CAPACITOR VALUES ARE IN MICROFARADS

Figure FO-1. Rescue Hoist Electrical Schematic

The Metric System and Equivalents

Linear Measure

1 centimeter = 10 millimeters = .39 inch
 1 decimeter = 10 centimeters = 3.94 inches
 1 meter = 10 decimeters = 39.37 inches
 1 dekameter = 10 meters = 32.8 feet
 1 hectometer = 10 dekameters = 328.08 feet
 1 kilometer = 10 hectometers = 3,280.8 feet

Weights

1 centigram = 10 milligrams = .15 grain
 1 decigram = 10 centigrams = 1.54 grains
 1 gram = 10 decigrams = .035 ounce
 1 decagram = 10 grams = .35 ounce
 1 hectogram = 10 decagrams = 3.52 ounces
 1 kilogram = 10 hectograms = 2.2 pounds
 1 quintal = 100 kilograms = 220.46 pounds
 1 metric ton = 10 quintals = 1.1 short tons

Liquid Measure

1 centiliter = 10 milliliters = .34 fl. ounce
 1 deciliter = 10 centiliters = 3.38 fl. ounces
 1 liter = 10 deciliters = 33.81 fl. ounces
 1 dekaliter = 10 liters = 2.64 gallons
 1 hectoliter = 10 dekaliters = 26.42 gallons
 1 kiloliter = 10 hectoliters = 264.18 gallons

Square Measure

1 sq. centimeter = 100 sq. millimeters = .155 sq. inch
 1 sq. decimeter = 100 sq. centimeters = 15.5 sq. inches
 1 sq. meter (centare) = 100 sq. decimeters = 10.76 sq. feet
 1 sq. dekameter (are) = 100 sq. meters = 1,076.4 sq. feet
 1 sq. hectometer (hectare) = 100 sq. dekameters = 2.47 acres
 1 sq. kilometer = 100 sq. hectometers = .386 sq. mile

Cubic Measure

1 cu. centimeter = 1000 cu. millimeters = .06 cu. inch
 1 cu. decimeter = 1000 cu. centimeters = 61.02 cu. inches
 1 cu. meter = 1000 cu. decimeters = 35.31 cu. feet

Approximate Conversion Factors

<i>To change</i>	<i>To</i>	<i>Multiply by</i>	<i>To change</i>	<i>To</i>	<i>Multiply by</i>
inches	centimeters	2.540	ounce-inches	Newton-meters	.007062
feet	meters	.305	centimeters	inches	.394
yards	meters	.914	meters	feet	3.280
miles	kilometers	1.609	meters	yards	1.094
square inches	square centimeters	6.451	kilometers	miles	.621
square feet	square meters	.093	square centimeters	square inches	.155
square yards	square meters	.836	square meters	square feet	10.764
square miles	square kilometers	2.590	square meters	square yards	1.196
acres	square hectometers	.405	square kilometers	square miles	.386
cubic feet	cubic meters	.028	square hectometers	acres	2.471
cubic yards	cubic meters	.765	cubic meters	cubic feet	35.315
fluid ounces	milliliters	29.573	cubic meters	cubic yards	1.308
pints	liters	.473	milliliters	fluid ounces	.034
quarts	liters	.946	liters	pints	2.113
gallons	liters	3.785	liters	quarts	1.057
ounces	grams	28.349	liters	gallons	.264
pounds	kilograms	.454	grams	ounces	.035
short tons	metric tons	.907	kilograms	pounds	2.205
pound-feet	Newton-meters	1.356	metric tons	short tons	1.102
pound-inches	Newton-meters	.11296			

Temperature (Exact)

F	Fahrenheit temperature	5/9 (after subtracting 32)	Celsius temperature	C
----------	------------------------	----------------------------	---------------------	----------

